

HCD5G60120H Silicon Carbide Schottky Diode

$$V_{RRM} = 1200V$$

$$I_F(T_C=155^\circ C) = 60 A$$

$$Q_C = 450 nC$$

Features

- 1200 V Schottky Rectifier
- Zero Reverse Recovery Current
- High-Frequency Operation
- Temperature-Independent Switching
- Extremely Fast Switching

Benefits

- Replace Bipolar with Unipolar Rectifiers
- Essentially No Switching Losses
- High Efficiency
- Reduction of Heat Sink Requirements
- Parallel Devices Without Thermal Runaway

Applications

- Switching Mode Power Supply
- Boost Diodes in PFC
- DC/DC Converters
- AC/DC Converters
- Free Wheeling Diodes in Inverter

Maximum Ratings $T_c = 25^\circ C$ (unless otherwise specified)

Symbol	Parameter	Value	Unit	Test Conditions	Note
V_{RRM}	Repetitive Peak Reverse Voltage	1200	V		
V_{RSM}	Surge Peak Reverse Voltage	1300	V		
V_R	DC Peak Reverse Voltage	1200	V		
I_F	Continuous Forward Current	149 80 60	A	$T_c=25^\circ C$ $T_c=135^\circ C$ $T_c=144^\circ C$	Fig. 3
I_{FSM}	Non- Repetitive Forward Surge Current		A	$T_c=25^\circ C, t_p=10 ms, Half Sine Pulse$	
P_{tot}	Power Dissipation	713 309	W	$T_c=25^\circ C$ $T_c=110^\circ C$	Fig. 4
T_j	Operating Junction Range	-55 to +175	$^\circ C$		
T_{stg}	Storage Temperature Range	-55 to +175	$^\circ C$		

Package



TO-247-2



Part Number	Package	Marking
HCD5G60120H	TO-247-2	HCD5G60120H

Electrical Characteristics

Symbol	Parameter	Typ.	Max.	Unit	Test Conditions	Note
V_F	Forward Voltage	1.65 2.5	1.9 3.0	V	$I_F = 60A, T_J = 25^\circ C$ $I_F = 60A, T_J = 175^\circ C$	Fig. 1
I_R	Reverse Current	25 150	200 800	μA	$V_R = 1200V, T_J = 25^\circ C$ $V_R = 1200V, T_J = 175^\circ C$	Fig. 2
Q_C	Total Capacitive Charge	150		nC	$V_R = 800V, I_F = 60A,$ $T_J = 25^\circ C$	Fig. 6
C	Total Capacitance	10747 349 298		pF	$V_R = 0V, T_J = 25^\circ C, f = 1\text{ MHz}$ $V_R = 400V, T_J = 25^\circ C, f = 1\text{ MHz}$ $V_R = 800V, T_J = 25^\circ C, f = 1\text{ MHz}$	Fig. 5
E_C	Capacitance Stored Energy	119		μJ	$V_R = 800V, T_J = 25^\circ C$	Fig. 7

Note : This is a majority carrier diode, so there is no reverse recovery charge.

Thermal Characteristics

Symbol	Parameter	Min.	Typ.	Max.	Unit	Note
$R_{\theta JC}$	Thermal Resistance from Junction to Case		0.21		$^\circ C/W$	Fig.8

Typical Performance

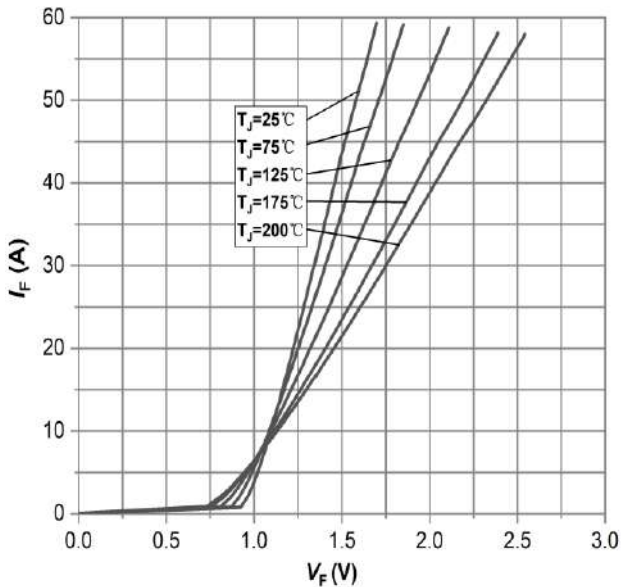

Figure 1: Forward Characteristics

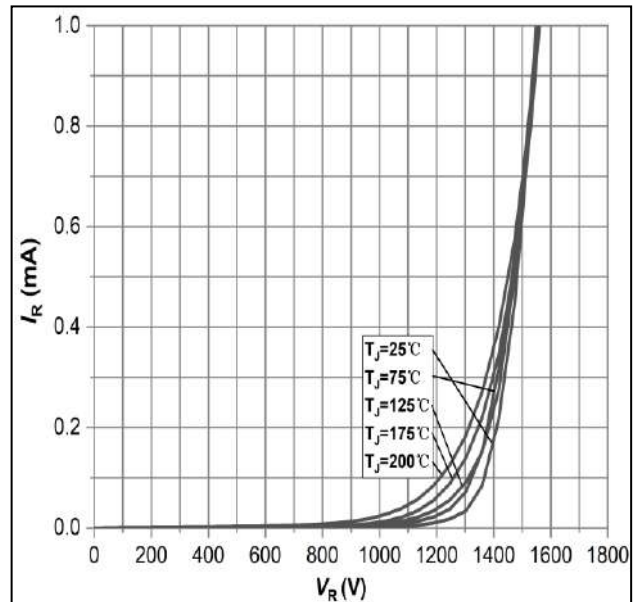

Figure 2: Reverse Characteristics

Typical Performance

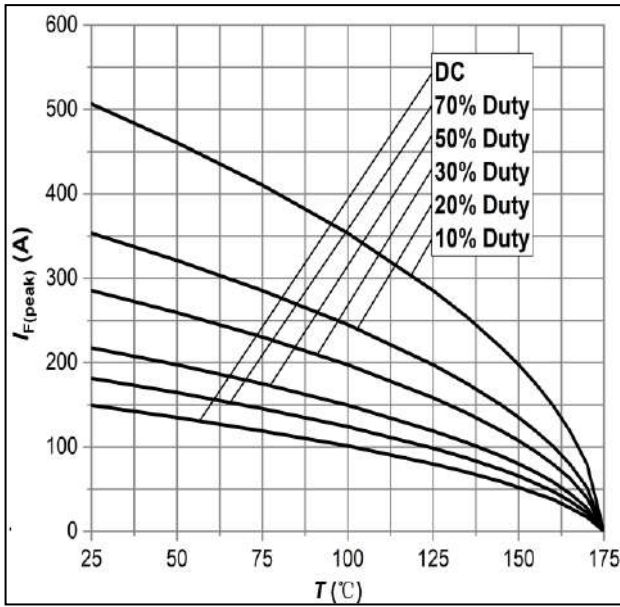

Figure 3: Current Derating

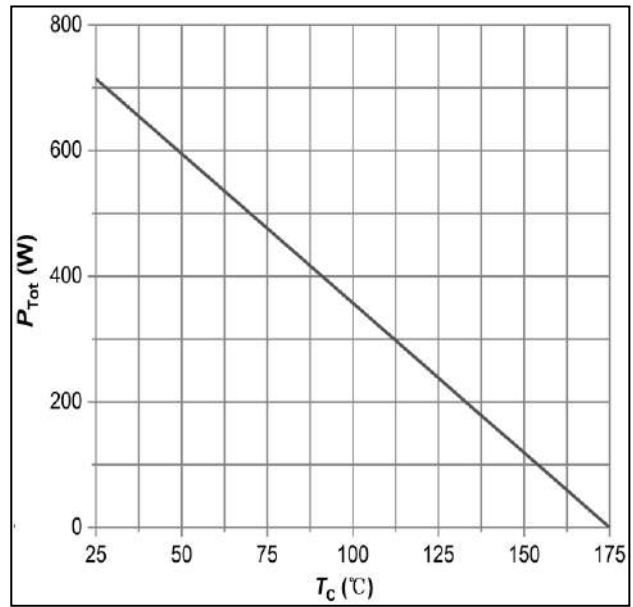

Figure 4: Power Derating

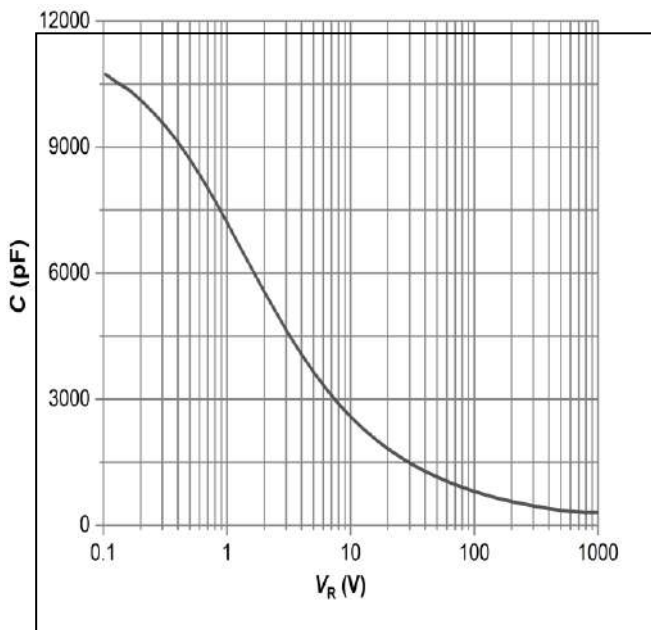

Figure 5: Capacitance vs. Reverse Voltage

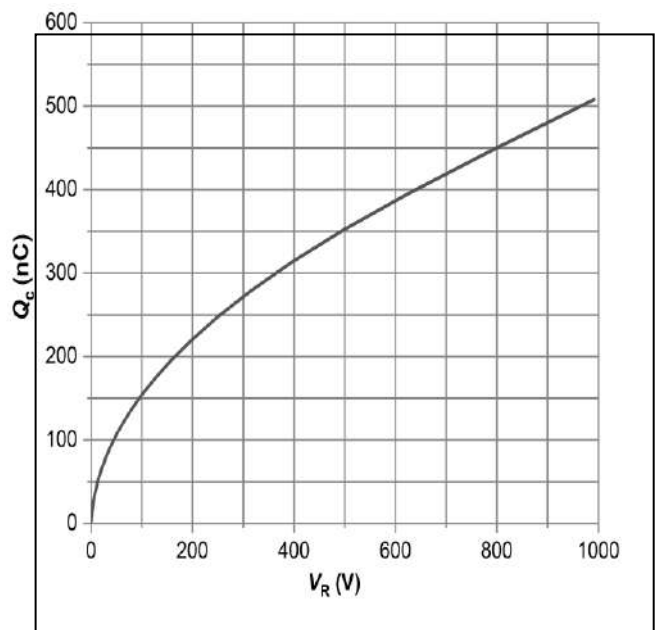

Figure 6: Total Capacitance Charge vs. Reverse Voltage

Typical Performance

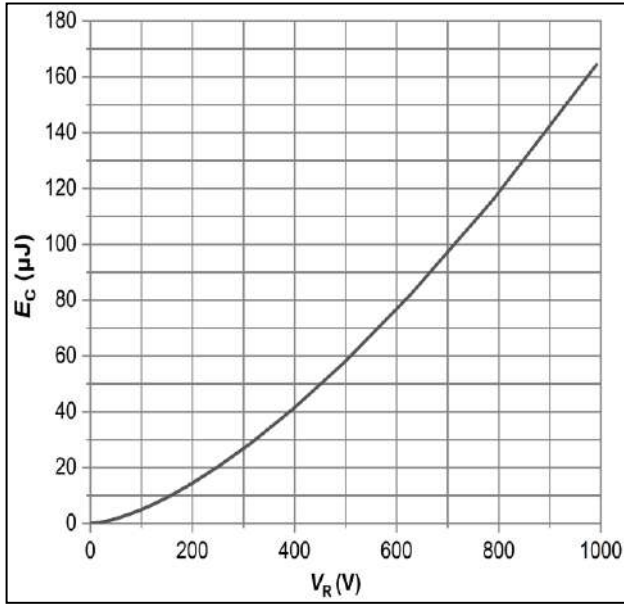

Figure 7: Typical Capacitance Stored Energy

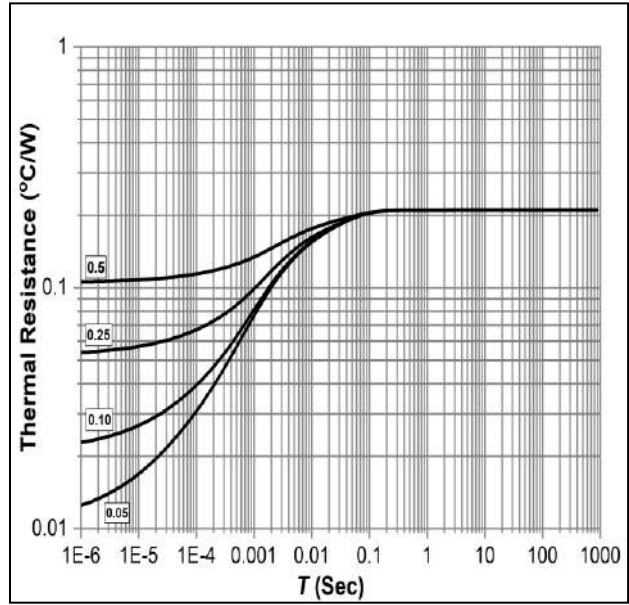
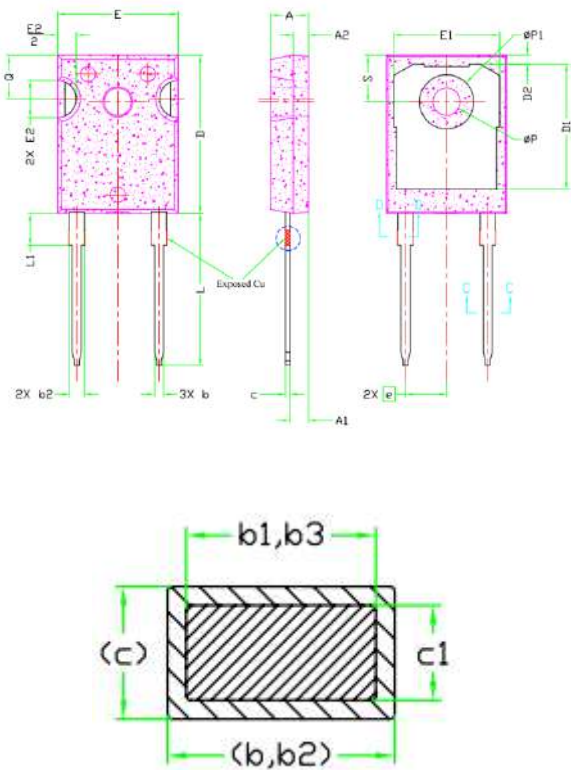

Figure 8: Transient Thermal Impedance

Package Dimensions

TO-247-2



SYMBOL	DIMENSIONS			NOTES
	Min.	NOM	Max.	
A	4.83	5.02	5.21	
A1	2.29	2.41	2.55	
A2	1.50	2.00	2.49	
b	1.12	1.20	1.33	
b1	1.12	1.20	1.28	
b2	1.91	2.00	2.39	6
b3	1.91	2.00	2.34	
C	0.55	0.60	0.69	6
c1	0.55	0.60	0.65	
D	20.88	20.95	21.10	4
D1	16.25	16.55	17.65	5
D2	0.51	1.19	1.35	
E	15.75	15.94	16.13	4
E1	13.46	14.02	14.16	5
E2	4.32	4.91	5.49	3
e	5.44BSC			
L	19.81	20.07	20.32	
L1	4.10	4.19	4.40	6
ØP	3.56	3.61	3.65	7
ØP1	7.19REF.			
Q	5.39	5.79	6.20	
S	6.04	6.17	6.30	

Revision History

Document Version	Description of Changes
RevX.0.1	Released

Zhejiang HIITIO New Energy Co., Ltd

ADD : NO.1125 Zhixing Road,Qiaonan District, Xiaoshan Economic and
Technological Development Zone, Hangzhou, Zhejiang

TEL :400-667-9977

