

HCG100F3L65B2A

$V_{CES}=650V$, I_C (nom) =100A

Features

- Low inductive design
- Low V_{cesat} with high junction temperature
- Fast & soft reverse recovery anti-parallel FWD
- Low Switching Losses

Benefits

- Higher System Efficiency
- Reduce cooling requirements
- Increased power density
- Enabling higher frequency

Applications

- Inverter for motor drive
- AC and DC servo drive amplifier
- Uninterruptible power supply

Package



Absolute Maximum Ratings $T_c=25^{\circ}C$ unless otherwise noted

TI-T4 IGBT

Symbol	Parameter	Value	Unit
V_{CES}	Collector-Emitter Voltage	650	V
V_{GES}	Gate - Emitter Voltage	± 20	V
I_C	Collector Current @ $T_C = 25^{\circ}C$, $T_{vj} = 150^{\circ}C$	100	A
I_{CM}	Pulsed Collector Current $t_p = 1ms$	200	A

D1-D4 Diode

Symbol	Parameter	Value	Unit
V_{RRM}	Repetitive Peak Reverse Voltage	650	V
I_F	Diode Continuous Forward Current	100	A
I_{FM}	Diode Maximum Forward Current $t_p = 1ms$	200	A

D5,D6 Diode

Symbol	Parameter	Value	Unit
V_{RRM}	Repetitive Peak Reverse Voltage	650	V
I_F	Diode Continuous Forward Current	100	A
I_{FM}	Diode Maximum Forward Current $t_p = 1ms$	200	A

T1-T4 IGBT Characteristics $T_c = 25^\circ C$ unless otherwise noted

Symbol	Parameter	Min.	Typ.	Max.		Test Conditions
$V_{CE(sat)}$	Collector to Emitter Saturation Voltage		1.65	2.10	V	$I_c = 100A, V_{GE} = 15V, T_j = 25^\circ C$
			2.00			$I_c = 100A, V_{GE} = 15V, T_j = 125^\circ C$
			2.10			$I_c = 100A, V_{GE} = 15V, T_j = 150^\circ C$
$V_{GE(th)}$	Gate-Emitter Threshold Voltage	4.8	5.8	6.2	V	$I_c = 3mA, V_{CE} = V_{GE}, T_j = 25^\circ C$
I_{CES}	Collector Cut-Off Current			1.0	mA	$V_{CE} = V_{CES}, V_{GE} = 0V, T_j = 25^\circ C$
I_{GES}	Gate-Emitter Leakage Current			400	nA	$V_{GE} = V_{GES}, V_{CE} = 0V, T_j = 25^\circ C$
E_{On}	Turn -On Switching Energy	--	1.52	--	mJ	$V_{CC} = 300V, I_c = 100A$
E_{Off}	Turn Off Switching Energy	--	5.23	--		$R_G = 10\Omega, V_{GE} = \pm 15V, T_j = 25^\circ C$
$t_{d(on)}$	Turn-on Delay Time	--	62	--	ns	
t_r	Turn-on Rise Time	--	254	--		
$t_{d(off)}$	Turn-off Delay Time	--	188	--		
t_f	Turn- off Fall Time	--	63	--		
I_{sc}	SC Data		500		A	$t_p \leq 6\mu s, V_{GE} = 15V, T_j = 125^\circ C, V_{CC} = 360V, V_{CEM} \leq 650V$
R_{thJC}	Thermal resistance, junction to case		0.435		K/W	per IGBT
R_{thCH}	Thermal resistance, case to heatsink		0.485		K/W	per IGBT
$T_{vj op}$	Temperature under switching conditions	-40		175	$^\circ C$	

D1-D4 Diode Characteristics $T_c = 25^\circ\text{C}$ unless otherwise noted

Symbol	Parameter	Min.	Typ.	Max.	Unit	Test Conditions
V_F	Diode Forward Voltage		1.55	1.95	V	$I_c=100\text{A}, V_{GE}=0\text{V}, T_j=25^\circ\text{C}$
			1.40			$I_F=100\text{A}, V_{GE}=0\text{V}, T_j=125^\circ\text{C}$
			1.35			$I_F=100\text{A}, V_{GE}=0\text{V}, T_j=150^\circ\text{C}$
Q_r	Recovered Charge	--	1.25	--	μC	$V_R=300\text{V}, I_F=100\text{A},$ $-di/dt=2400\text{A}/\mu\text{s}, V_{GE}=-15\text{V}$ $T_j=25^\circ\text{C}$
I_{RM}	Peak Reverse Recovery Current	--	30	--	A	
E_{rec}	Reverse Recovery Energy	--	0.25	--	mJ	
R_{thJC}	Thermal resistance, junction to case		0.625		K/W	<i>per DIODE</i>
R_{thCH}	Thermal resistance, case to heatsink		0.585		K/W	<i>per DIODE</i>
$T_{vj op}$	Temperature under switching conditions	-40		175	$^\circ\text{C}$	

D5-D6 Diode Characteristics $T_c = 25^\circ\text{C}$ unless otherwise noted

Symbol	Parameter	Min.	Typ.	Max.	Unit	Test Conditions
V_F	Diode Forward Voltage		1.55	1.95	V	$I_c=100\text{A}, V_{GE}=0\text{V}, T_j=25^\circ\text{C}$
			1.40			$I_F=100\text{A}, V_{GE}=0\text{V}, T_j=125^\circ\text{C}$
			1.35			$I_F=100\text{A}, V_{GE}=0\text{V}, T_j=150^\circ\text{C}$
Q_r	Recovered Charge	--	1.05	--	μC	$V_R=300\text{V}, I_F=100\text{A},$ $-di/dt=2400\text{A}/\mu\text{s}, V_{GE}=-15\text{V}$ $T_j=25^\circ\text{C}$
I_{RM}	Peak Reverse Recovery Current	--	33	--	A	
E_{rec}	Reverse Recovery Energy	--	0.21	--	mJ	
R_{thJC}	Thermal resistance, junction to case		0.615		K/W	<i>per DIODE</i>
R_{thCH}	Thermal resistance, case to heatsink		0.565		K/W	<i>per DIODE</i>
$T_{vj op}$	Temperature under switching conditions	-40		175	$^\circ\text{C}$	

NTC-Thermistor Characteristics

Symbol	Parameter	Test Conditions	Min.	Typ.	Max.	Unit
R_{25}	Rated Resistance	$T_{NTC}=25\text{ }^{\circ}\text{C}$		5.0		k Ω
$B_{25/50}$	B-value	$R_2=R_{25\text{exp}}[B_{25/50} (1/T_2-1/(298,15\text{K}))]$		3380		K
$B_{25/80}$	B-value	$R_2=R_{25\text{exp}}[B_{25/80} (1/T_2-1/(298,15\text{K}))]$		3435		K

Package

Symbol	Parameter	Test Conditions	Values	Unit
V_{ISOL}	Isolation test voltage	RMS, f=50Hz, t=1min	2.5	kV
d_{Creep}	Creepage distance		10.0	mm
d_{Clear}	Clearance		6.3	mm
	Internal isolation	basic insulation (class 1, IEC 61140)	Al ₂ O ₃	
d_{Clear}	Clearance		5.0	mm
CTI	Comparative tracking		> 200	
L_{sCE}	Stray inductance module		14	nH
T_{stg}	Storage temperature		-40~125	$^{\circ}\text{C}$
M	Mounting torque for module mounting	M5, Screw	1.3~1.5	Nm
G	Weight		39	g

Circuit diagram

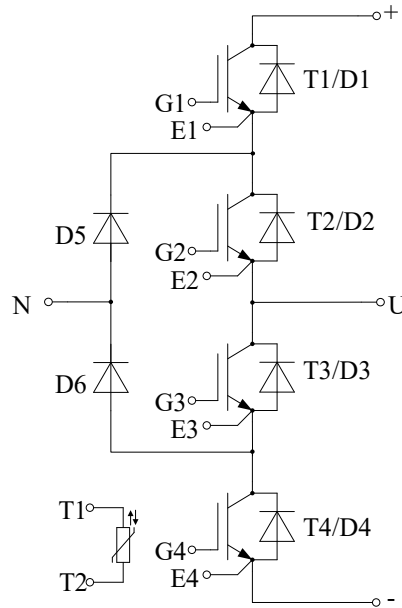

Package Dimensions Dimensions in Millimeters

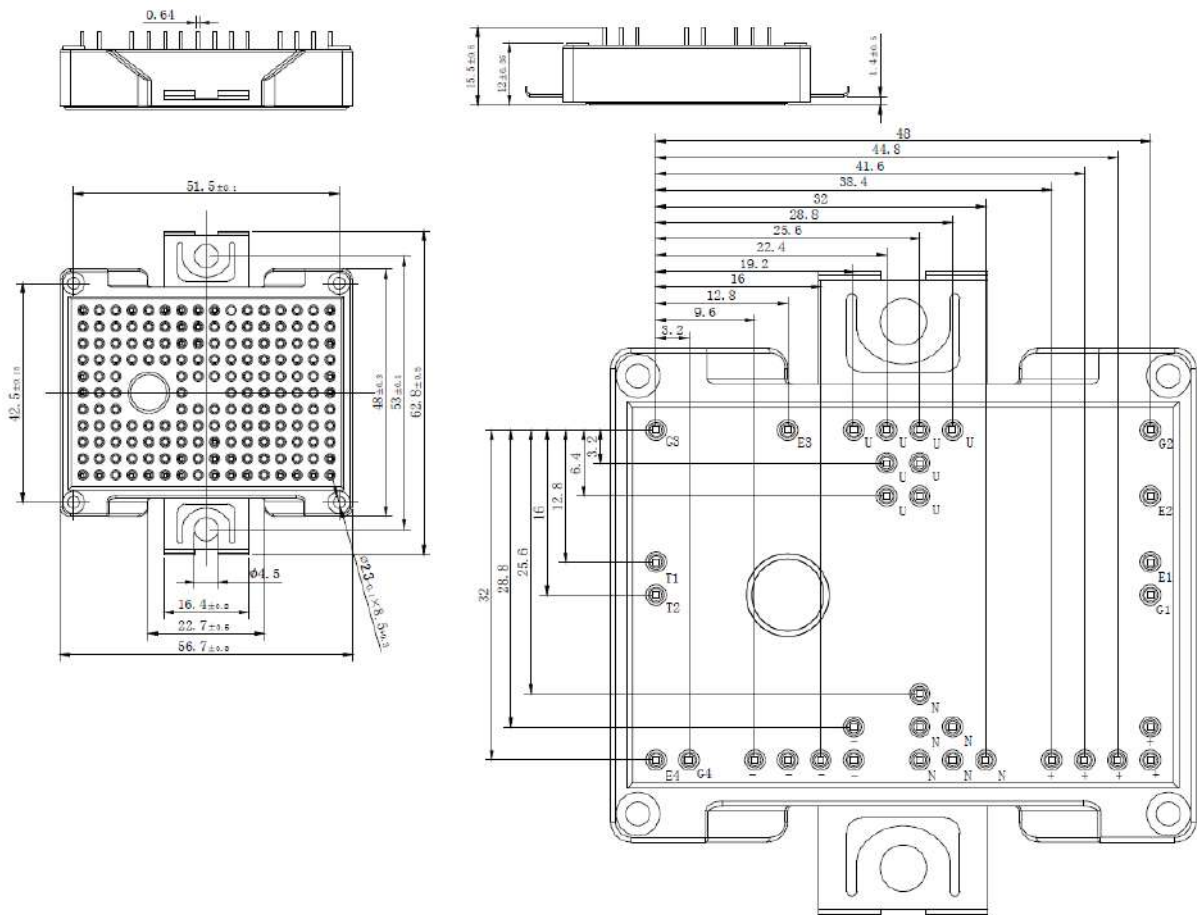

Revision History

Document Version	Description of Changes
RevX.0.1	Released

Zhejiang HIITIO New Energy Co., Ltd

ADD : NO.1125 Zhixing Road,Qiaonan District, Xiaoshan Economic and Technological Development Zone, Hangzhou, Zhejiang

TEL :400-667-9977

