

HCG200FF120A2D

$V_{CES}=1200V$, I_C (nom) =200A

Features

- Low inductive design
- Low V_{cesat} with high junction temperature
- Fast & soft reverse recovery anti-parallel FWD
- Low Switching Losses

Benefits

- Higher System Efficiency
- Reduce cooling requirements
- Increased power density
- Enabling higher frequency

Applications

- Inverter for motor drive
- AC and DC servo drive amplifier
- Uninterruptible power supply

Package



Absolute Maximum Ratings $T_c=25^{\circ}C$ unless otherwise noted

TI-T4 IGBT

Symbol	Parameter	Value	Unit
V_{CES}	Collector-Emitter Voltage	1200	V
V_{GES}	Gate - Emitter Voltage	± 20	V
I_C	Collector Current @ $T_C = 25^{\circ}C$, $T_{vj} = 150^{\circ}C$	200	A
I_{CM}	Pulsed Collector Current $t_p = 1ms$	400	A

D1-D4 Diode

Symbol	Parameter	Value	Unit
V_{RRM}	Repetitive Peak Reverse Voltage	1200	V
I_F	Diode Continuous Forward Current	200	A
I_{FM}	Diode Maximum Forward Current $t_p = 1ms$	400	A

IGBT -inverter Characteristics $T_c = 25^\circ\text{C}$ unless otherwise noted

Symbol	Parameter	Min.	Typ.	Max.		Test Conditions
$V_{CE(sat)}$	Collector to Emitter Saturation Voltage		2.15	2.60	V	$I_c=200\text{A}, V_{GE}=15\text{V}, T_j=25^\circ\text{C}$
			2.65			$I_c=200\text{A}, V_{GE}=15\text{V}, T_j=125^\circ\text{C}$
			2.10			$I_c=200\text{A}, V_{GE}=15\text{V}, T_j=150^\circ\text{C}$
$V_{GE(th)}$	Gate-Emitter Threshold Voltage	4.8	5.7	6.3	V	$I_c=2.0\text{mA}, V_{CE}=V_{GE}, T_j=25^\circ\text{C}$
I_{CES}	Collector Cut-Off Current			1.0	mA	$V_{CE}=V_{CES}, V_{GE}=0\text{V}, T_j=25^\circ\text{C}$
I_{GES}	Gate-Emitter Leakage Current			400	nA	$V_{GE}=V_{GES}, V_{CE}=0\text{V}, T_j=25^\circ\text{C}$
E_{On}	Turn-On Switching Energy	--	12.9	--	mJ	$V_{CC}=600\text{V}, I_c=200\text{A}$
E_{Off}	Turn Off Switching Energy	--	17.1	--		$R_G=5.1\Omega, V_{GE}=\pm 15\text{V}, T_j=25^\circ\text{C}$
$t_{d(on)}$	Turn-on Delay Time	--	373	--	ns	
t_r	Turn-on Rise Time	--	104	--		
$t_{d(off)}$	Turn-off Delay Time	--	459	--		
t_f	Turn-off Fall Time	--	168	--		
I_{sc}	SC Data		1200		A	$t_p \leq 10\mu\text{s}, V_{GE}=15\text{V}, T_j=125^\circ\text{C}, V_{CC}=900\text{V}, V_{CEM} \leq 1200\text{V}$
R_{thJC}	Thermal resistance, junction to case		0.092		K/W	<i>per IGBT</i>
R_{thCH}	Thermal resistance, case to heatsink		0.028		K/W	<i>per IGBT</i>
$T_{vj op}$	Temperature under switching conditions	-40		150	$^\circ\text{C}$	

D1-D4 Diode Characteristics $T_c = 25^\circ\text{C}$ unless otherwise noted

Symbol	Parameter	Min.	Typ.	Max.	Unit	Test Conditions
V_F	Diode Forward Voltage		1.65	2.05	V	$I_c=200\text{A}, V_{GE}=0\text{V}, T_j=25^\circ\text{C}$
			1.65			$I_F=200\text{A}, V_{GE}=0\text{V}, T_j=125^\circ\text{C}$
Q_r	Recovered Charge	--	17.7	--	μC	$V_R=600\text{V}, I_F=200\text{A}, -di/dt=3500\text{A}/\mu\text{s}, V_{GE}=-15\text{V}, T_j=25^\circ\text{C}$
I_{RM}	Peak Reverse Recovery Current	--	145	--	A	
E_{rec}	Reverse Recovery Energy	--	8.06	--	mJ	
R_{thJC}	Thermal resistance, junction to case		0.219		K/W	<i>per DIODE</i>
R_{thCH}	Thermal resistance, case to heatsink		0.068		K/W	<i>per DIODE</i>
$T_{vj op}$	Temperature under switching conditions	-40		150	$^\circ\text{C}$	

NTC-Thermistor Characteristics

Symbol	Parameter	Test Conditions	Min.	Typ.	Max.	Unit
R_{25}	Rated Resistance	$T_{NTC}=25\text{ }^{\circ}\text{C}$		5.0		k Ω
$B_{25/50}$	B-value	$R_2=R_{25\text{exp}}[B_{25/50}(1/T_2-1/(298,15\text{K}))]$		3380		K
$B_{25/80}$	B-value	$R_2=R_{25\text{exp}}[B_{25/80}(1/T_2-1/(298,15\text{K}))]$		3435		K

Package

Symbol	Parameter	Test Conditions	Values	Unit
V_{ISOL}	Isolation test voltage	RMS, f=50Hz, t=1min	2.5	kV
CTI	Comparative tracking		> 200	
L_{sCE}	Stray inductance module		20	nH
T_{stg}	Storage temperature		-40~125	$^{\circ}\text{C}$
M	Mounting torque for module mounting	M5, Screw	2.5~5	Nm
G	Weight		300	g

Circuit diagram

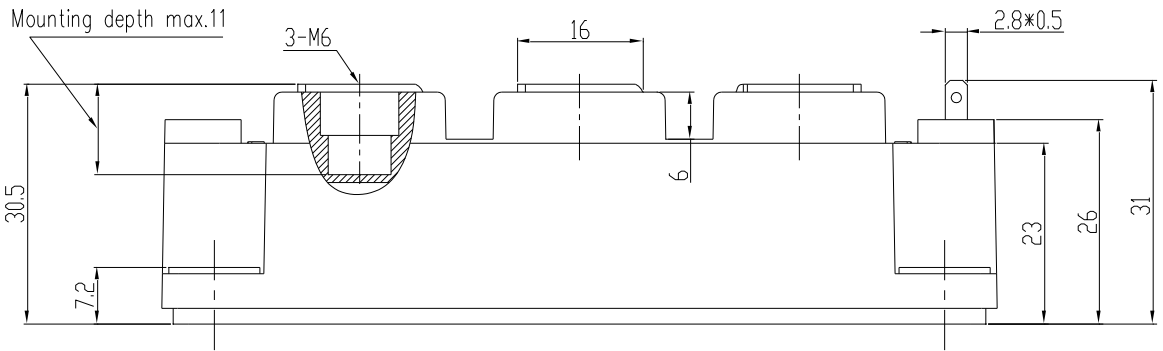
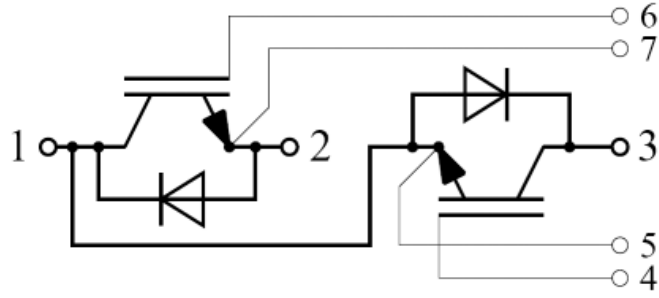

Package Dimensions Dimensions in Millimeters

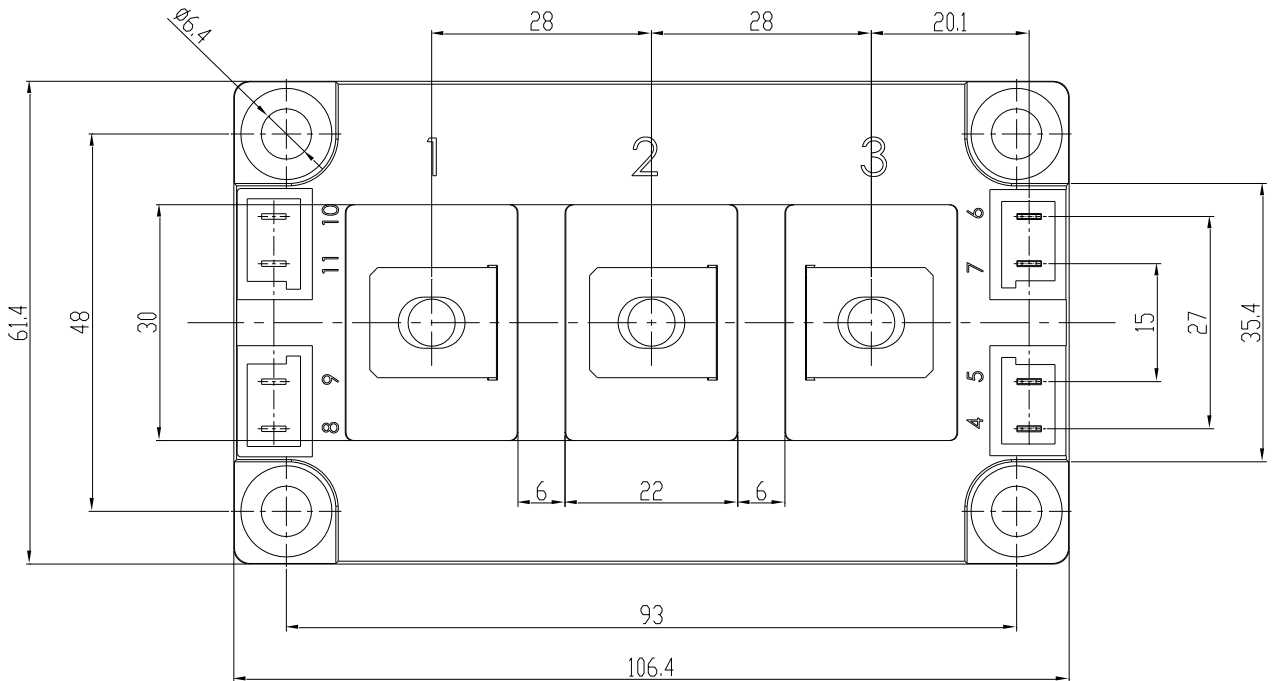

Revision History

Document Version	Description of Changes
RevX.0.1	Released

Zhejiang HIITIO New Energy Co., Ltd

ADD : NO.1125 Zhixing Road,Qiaonan District, Xiaoshan Economic and
Technological Development Zone, Hangzhou, Zhejiang

TEL :400-667-9977

