

HCM2G0040120D

1200V N-Channel Silicon Carbide Power MOSFET

V_{DS}	=	1200 V
$R_{DS(on)}$	=	37 mΩ
I_D	=	75 A

Features

- Optimized package with separate driver source pin
- High blocking voltage with low on-resistance
- High-speed switching with low capacitances
- Fast intrinsic diode with low reverse recovery (Q_{rr})
- Easy to parallel
- RoHS compliant

Benefits

- Higher System Efficiency
- Reduce cooling requirements
- Increased power density
- Enabling higher frequency
- Minimize gate ringing
- Reduction of system complexity and cost

Package

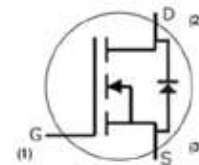

Applications

- Switch Mode Power Supplies
- DC/DC converters
- Solar Inverters
- Battery Chargers
- Motor Drives

Part Number	Package	Marking
HCM2G0040120D	TO-247-3	HCM2G0040120D

Maximum Ratings, at $T_J = 25^\circ\text{C}$, unless otherwise specified

Symbol	Parameter	Value	Unit	Test Conditions	Note
V_{DSmax}	Drain-Source Breakdown Voltage	1200	V	$V_{GS} = 0\text{ V}$, $I_D = 100\ \mu\text{A}$	
I_D	Continuous Drain Current	75	A	$V_{GS} = 20\text{ V}$, $T_C = 25\ ^\circ\text{C}$	Fig. 18
		53	A	$V_{GS} = 20\text{ V}$, $T_C = 100\ ^\circ\text{C}$	
$I_{D(pluse)}$	Pulsed Drain Current	150	A	Pulsed width t_p limited by T_{Jmax}	Fig. 21
P_D	Power Dissipation	330	W	$T_C = 25\ ^\circ\text{C}$	Fig. 19
$V_{GS,op}$	Recommend Gate Source Voltage (static)	-5/+20	V		
V_{GSmax}	Maximum Gate Source Voltage (dynamic)	-10/+25	V	AC ($f > 1\text{Hz}$)	
T_J, T_{stg}	Operating Junction and Storage Temperature Range	-55 to +175	$^\circ\text{C}$		
T_L	Soldering Temperature	260	$^\circ\text{C}$		

Electrical Characteristics, at $T_J = 25^\circ\text{C}$, unless otherwise specified

Symbol	Parameter	Min.	Typ.	Max.	Unit	Test Conditions	Note
Static							
BV_{DS}	Drain-Source Breakdown Voltage	1200	--	--	V	$V_{GS} = 0\text{ V}, I_D = 100\ \mu\text{A}$	
I_{DSS}	Zero Gate Voltage Drain Current	--1	100		μA	$V_{DS} = 1200\text{ V}, V_{GS} = 0\text{ V}$	
I_{GSS}	Gate-Source Leakage Current	--	10	25	nA	$V_{GS} = 20\text{ V}$	
$V_{GS(th)}$	Gate-Source Threshold Voltage	2	2.7	4	V	$I_D = 10\text{ mA}, V_{GS} = V_{DS}$	Fig. 11
		--	2.0	--	V	$I_D = 10\text{ mA}, V_{GS} = V_{DS}, T_J = 175^\circ\text{C}$	
$R_{DS(on)}$	Drain-Source On-Resistance	--	37	55	m Ω	$V_{GS} = 20\text{ V}, I_D = 40\text{ A}$	Fig. 7
		--	42	--	m Ω	$V_{GS} = 18\text{ V}, I_D = 40\text{ A}$	
		--	59	--	m Ω	$V_{GS} = 15\text{ V}, I_D = 40\text{ A}$	
		--	51	--	m Ω	$V_{GS} = 20\text{ V}, I_D = 40\text{ A}, T_J = 175^\circ\text{C}$	
		--	54	--	m Ω	$V_{GS} = 18\text{ V}, I_D = 40\text{ A}, T_J = 175^\circ\text{C}$	
		--	67	--	m Ω	$V_{GS} = 15\text{ V}, I_D = 40\text{ A}, T_J = 175^\circ\text{C}$	
Dynamic							
C_{iss}	Input Capacitance	--	2193	--	pF	$V_{GS} = 0\text{ V}, V_{DS} = 1000\text{ V}$ $f = 1.0\text{ MHz}, V_{AC} = 25\text{ mV}$	Fig. 17
C_{oss}	Output Capacitance	--	153	--			
C_{rss}	Reverse Transfer Capacitance	--	8	--			
E_{OSS}	C_{OSS} Stored Energy	--	83	--	μJ		Fig. 16
Q_g	Total Gate Charge	--	99	--	nC	$V_{DS} = 800\text{ V}$ $I_D = 40\text{ A}$ $V_{GS} = -5/+20\text{ V}$	Fig. 12
Q_{gs}	Gate-Source Charge	--	32	--			
Q_{gd}	Gate-Drain Charge	--	29	--			
$t_{d(on)}$	Turn-on Delay Time	--	18	--	ns	$V_{DS} = 800\text{ V}$ $V_{GS} = -5/+20\text{ V}$ $I_D = 40\text{ A}$ $R_{G(ext)} = 2.5\ \Omega$	
t_r	Turn-on Rise Time	--	65	--			
$t_{d(off)}$	Turn-off Delay Time	--	36	--			
t_f	Turn-off Fall Time	--	15	--			
$R_{G(int)}$	Internal Gate Resistance	--	2.0	--	Ω	$f = 1.0\text{ MHz}, V_{AC} = 25\text{ mV}$	

Body Diode Characteristics, at $T_J = 25^\circ\text{C}$, unless otherwise specified

Symbol	Parameter	Min.	Typ.	Max.	Unit	Test Conditions	Note
I_S	Continuous Diode Forward Current	--	--	75	A	$V_{GS} = -5\text{ V}$	
$I_{S(pulse)}$	Diode pulse Current	--	--	150	A	Pulse width t_p limited by T_{Jmax}	
V_{SD}	Diode Forward Voltage	--	4.0	--	V	$V_{GS} = 0\text{ V}, I_S = 20\text{ A}$	Fig. 8, 9, 10
		--	3.8	--	V	$V_{GS} = 0\text{ V}, I_S = 20\text{ A}, T_J = 175^\circ\text{C}$	
t_{rr}	Reverse Recovery Time	--	28	--	ns	$I_S = 20\text{ A}, V_{DS} = 800\text{ V}$	
Q_{rr}	Reverse Recovery Charge	--	232	--	nC	$V_{GS} = -5\text{ V}$	
I_{rrm}	Peak Reverse Recovery Current	--	13	--	A	$di/dt = 2100\text{ A}/\mu\text{s}$	

Thermal Characteristics

Symbol	Parameter	Min.	Typ.	Max.	Unit	Note
$R_{\theta JC}$	Thermal Resistance from Junction to Case	/	0.39	/	$^\circ\text{C}/\text{W}$	Fig. 20

Typical Performance

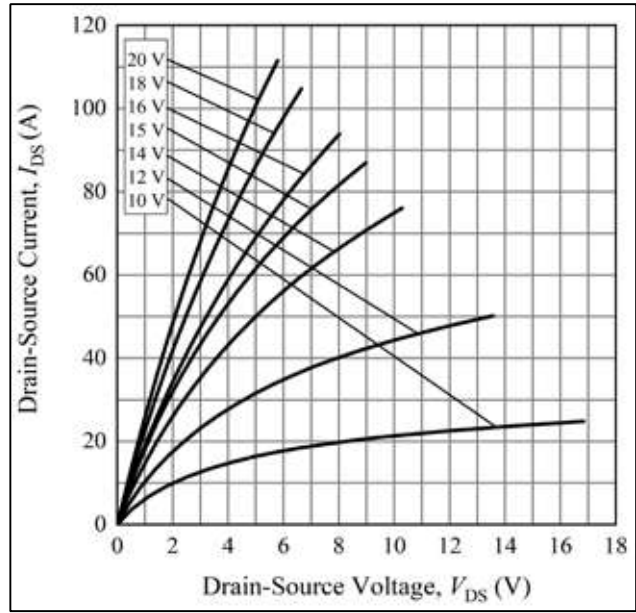
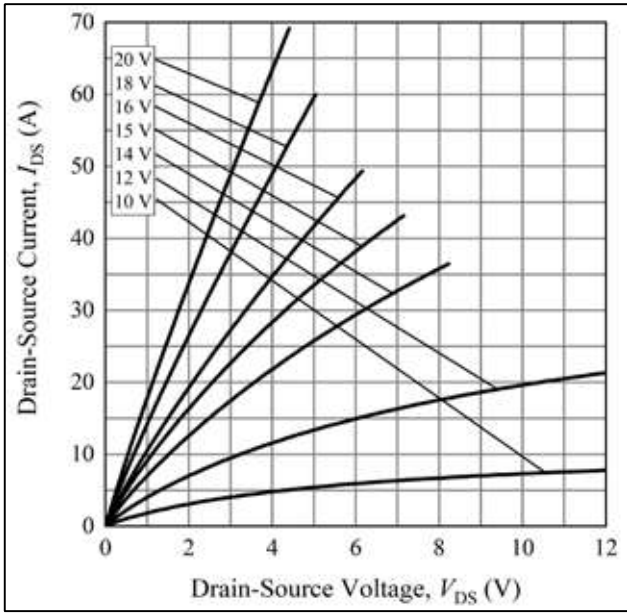

Figure 1: Typical Output Characteristics at $T_J = -55\text{ }^\circ\text{C}$

Figure 2: Typical Output Characteristics at $T_J = 25\text{ }^\circ\text{C}$

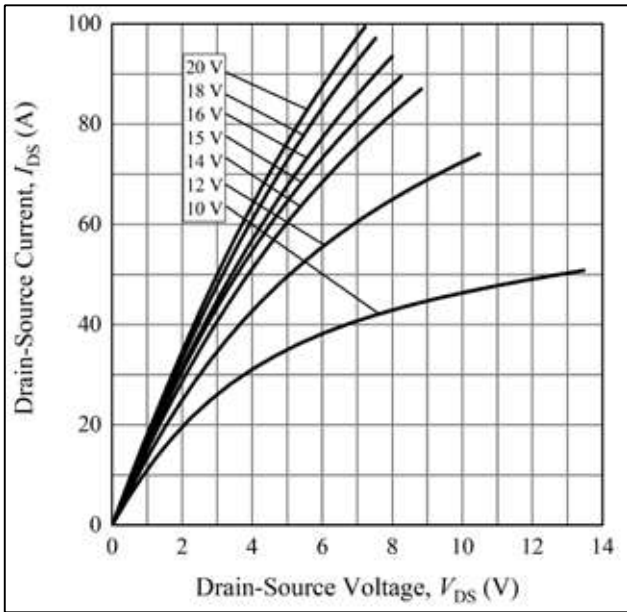

Figure 3: Typical Output Characteristics at $T_J = 175\text{ }^\circ\text{C}$

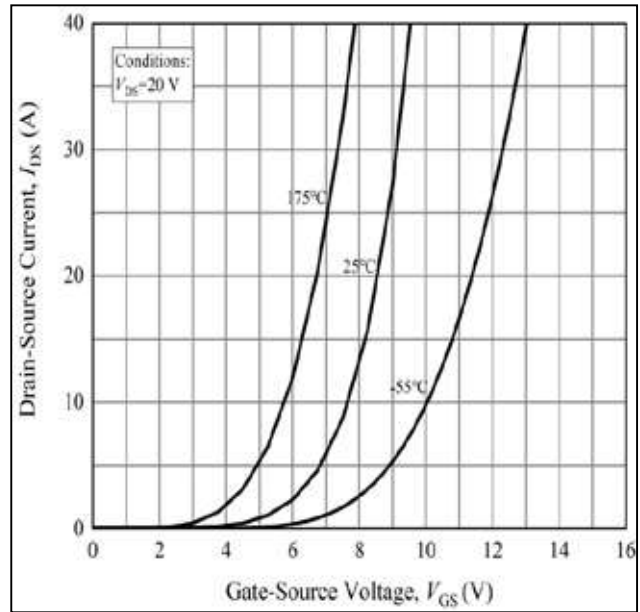

Figure 4: Typical Transfer Characteristics for Various Temperature

Typical Performance

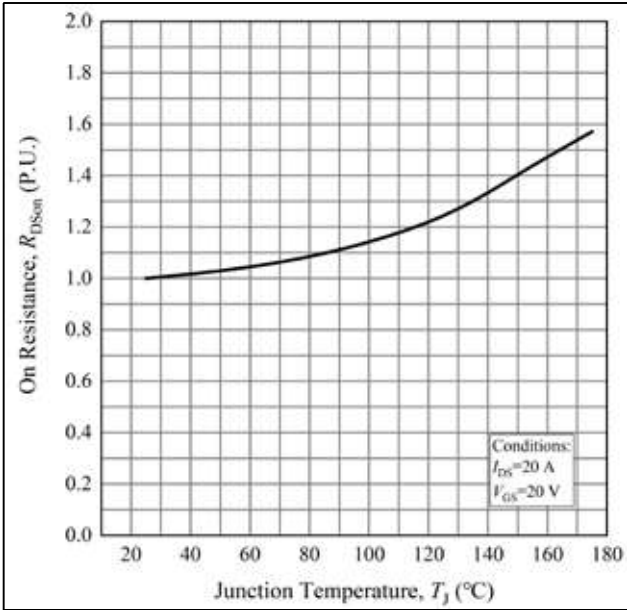

Figure 5: Normalized On-Resistance vs. Temperature

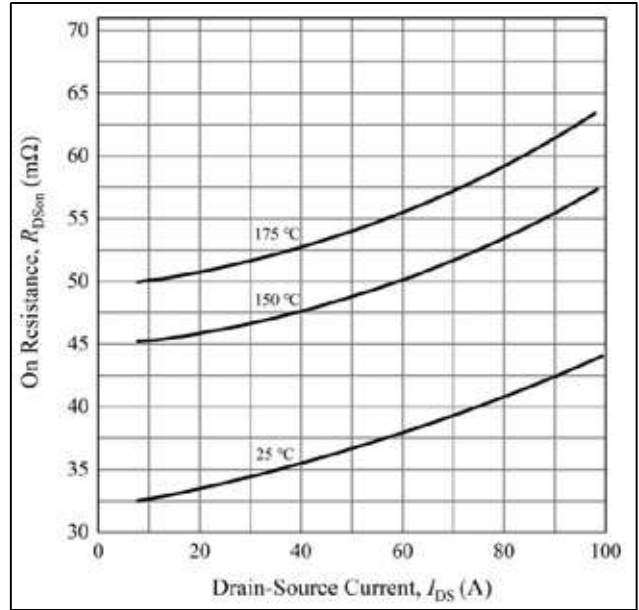

Figure 6: On-Resistance vs. Drain Current for Gate Various Temperatures

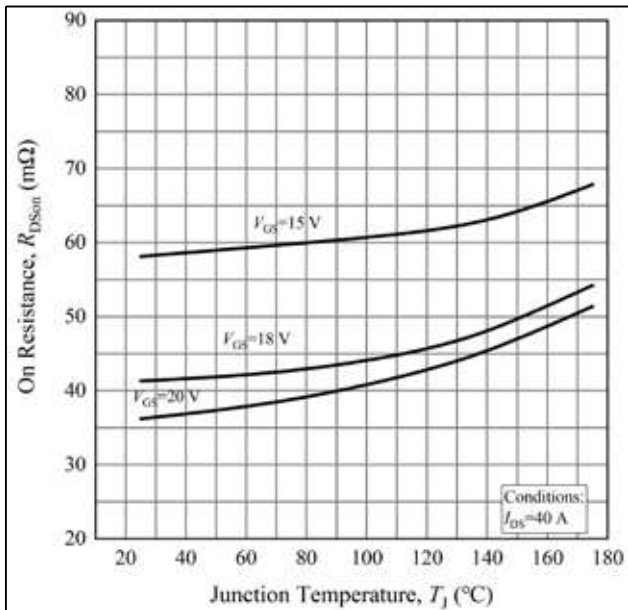

Figure 7: On-Resistance vs. Temperature for Various Voltage

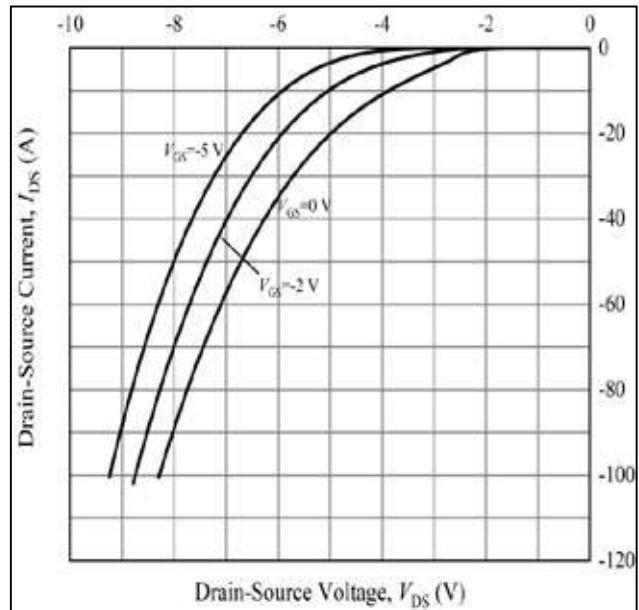

Figure 8: Typical Body Diode Characteristics at $T_J = -55\text{ }^\circ\text{C}$

Typical Performance

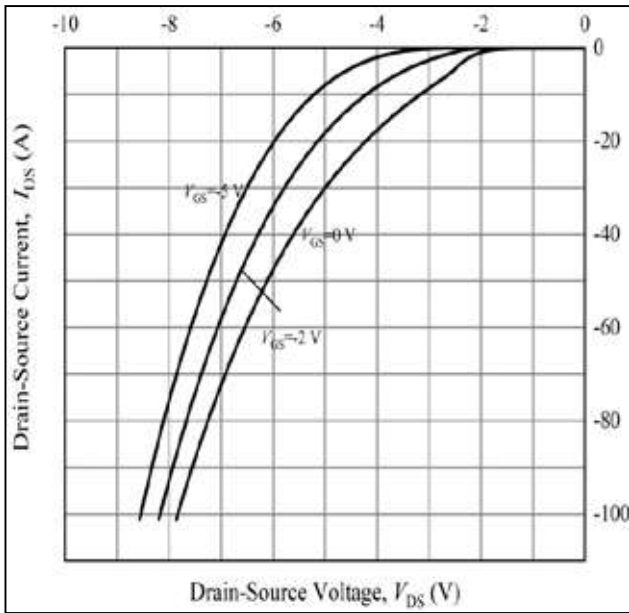

Figure 9: Typical Body Diode Characteristics at $T_J = 25\text{ }^\circ\text{C}$

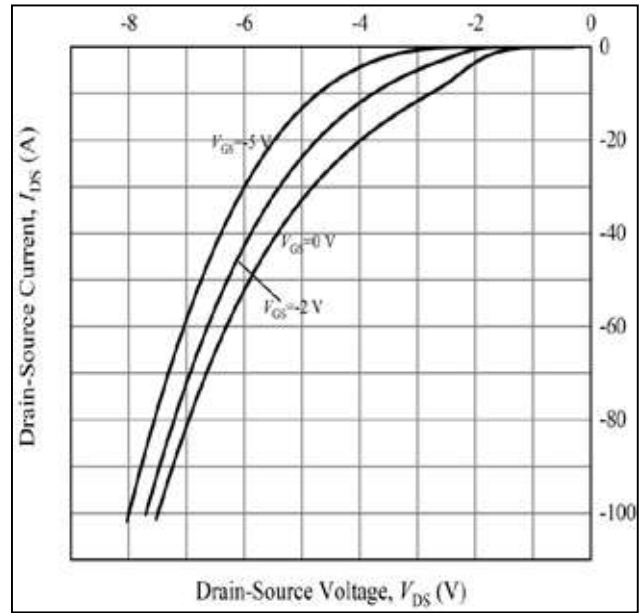

Figure 10: Typical Body Diode Characteristics at $T_J = 175\text{ }^\circ\text{C}$

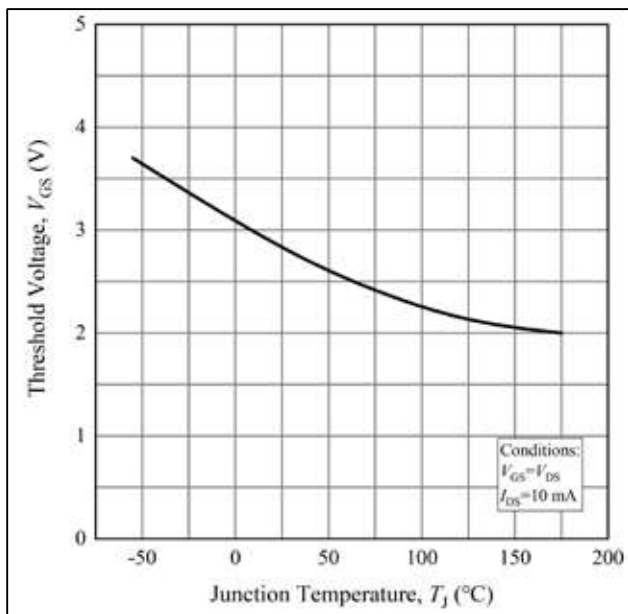

Figure 11: Typical Threshold Voltage vs. Temperature

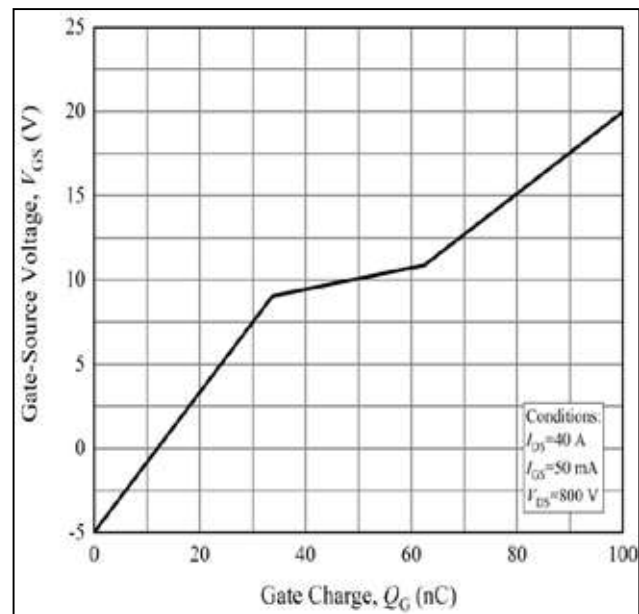

Figure 12: Typical Gate Charge Characteristics at $T_J = 25\text{ }^\circ\text{C}$

Typical Performance

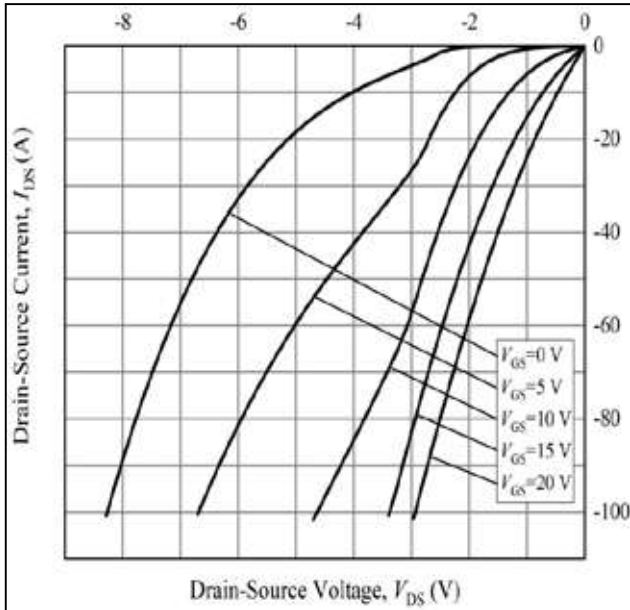

Figure 13: Typical 3rd Quadrant Characteristics
 $T_J = -55\text{ }^\circ\text{C}$

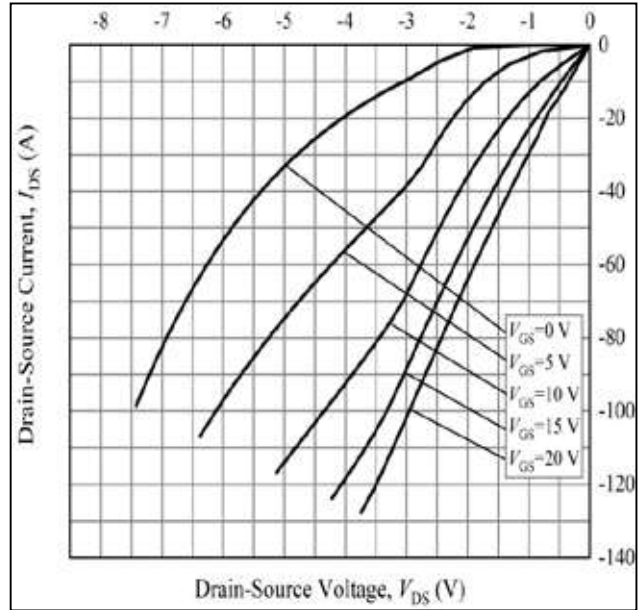

Figure 14: Typical 3rd Quadrant Characteristics at
 $T_J = 25\text{ }^\circ\text{C}$

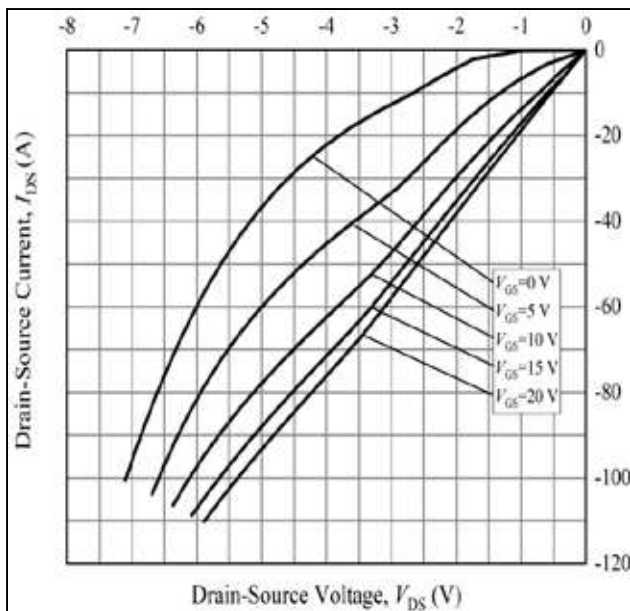

Figure 15: Typical 3rd Quadrant Characteristics
 at $T_J = 175\text{ }^\circ\text{C}$

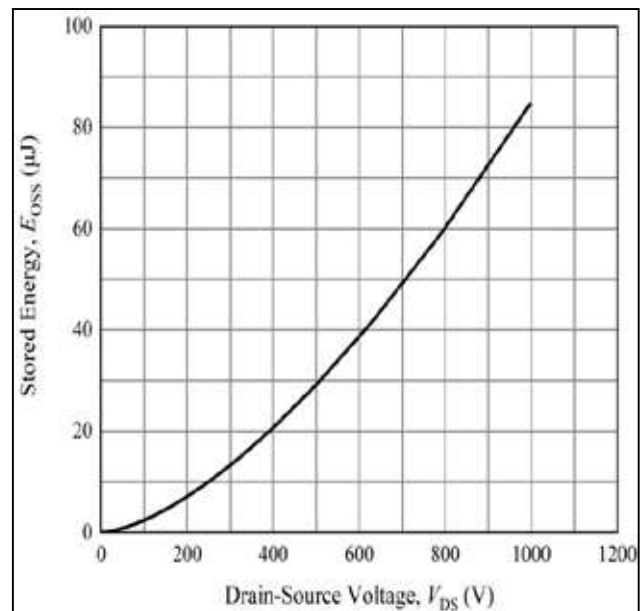

Figure 16: Typical Output Capacitor Stored Energy

Typical Performance

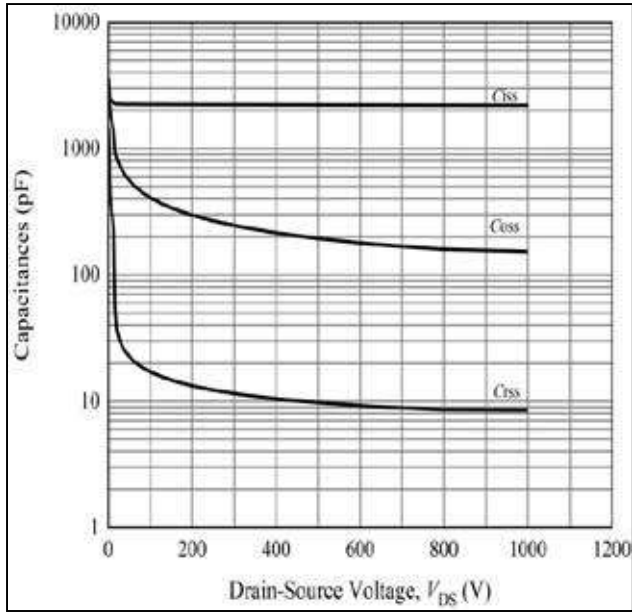

Figure 17: Typical Capacitances vs. Drain-Source Voltage

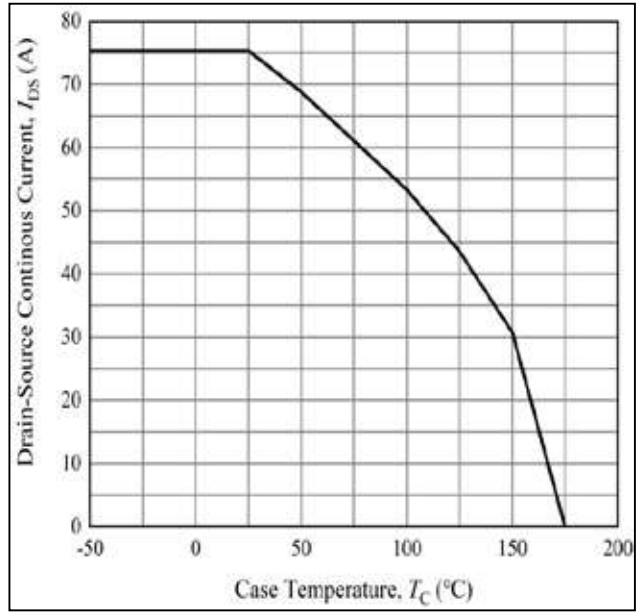

Figure 18: Continuous Drain Current Derating Curve

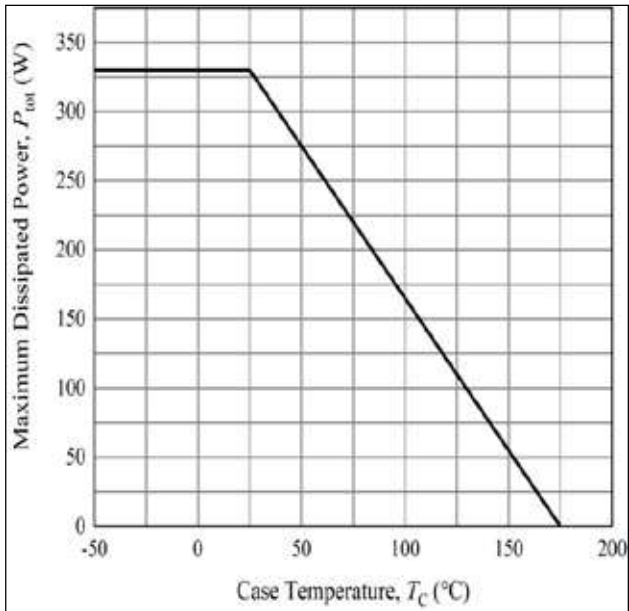

Figure 19: Power Dissipation Derating Curve

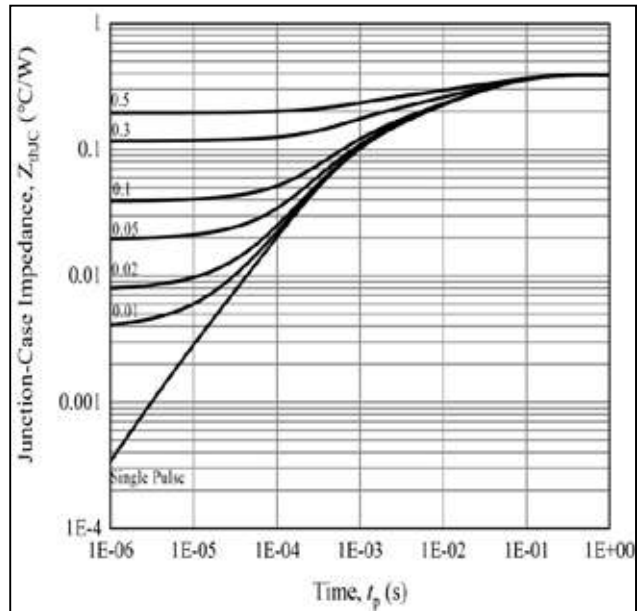

Figure 20: Typical Transient Thermal Impedance (Junction – Case) with Duty Cycle

Typical Performance

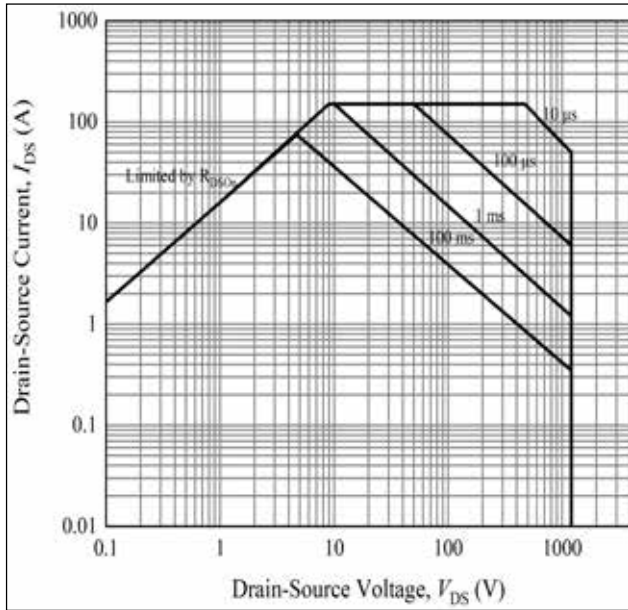

Figure 21: Safe Operate Area

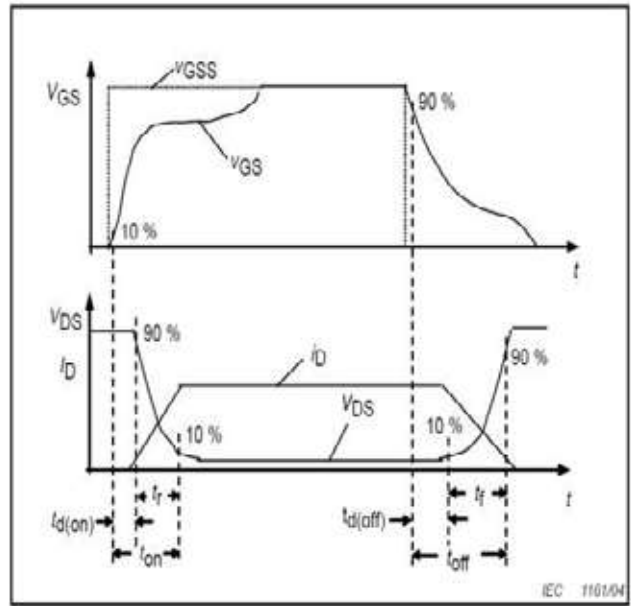

Figure 22: Resistive Switching Time Description

Test Circuit Schematic

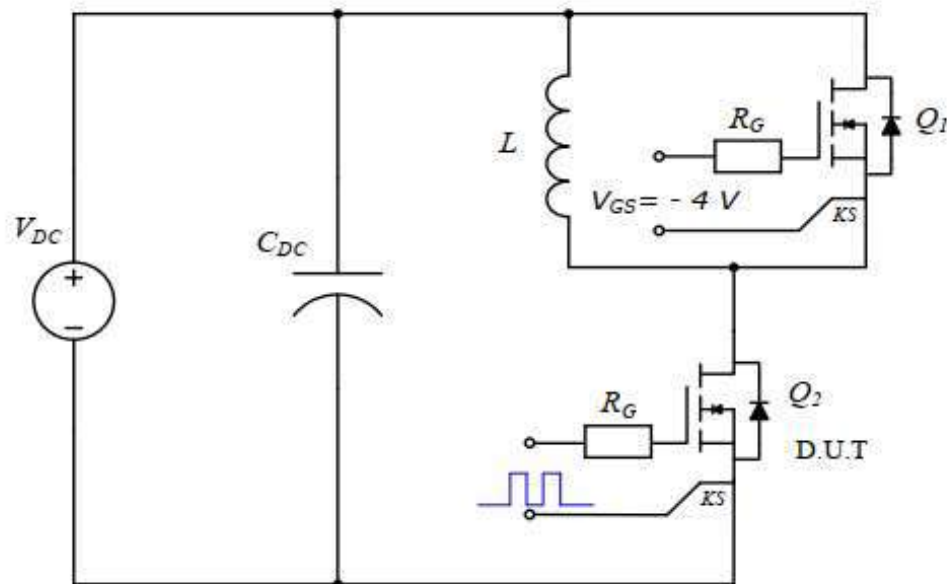
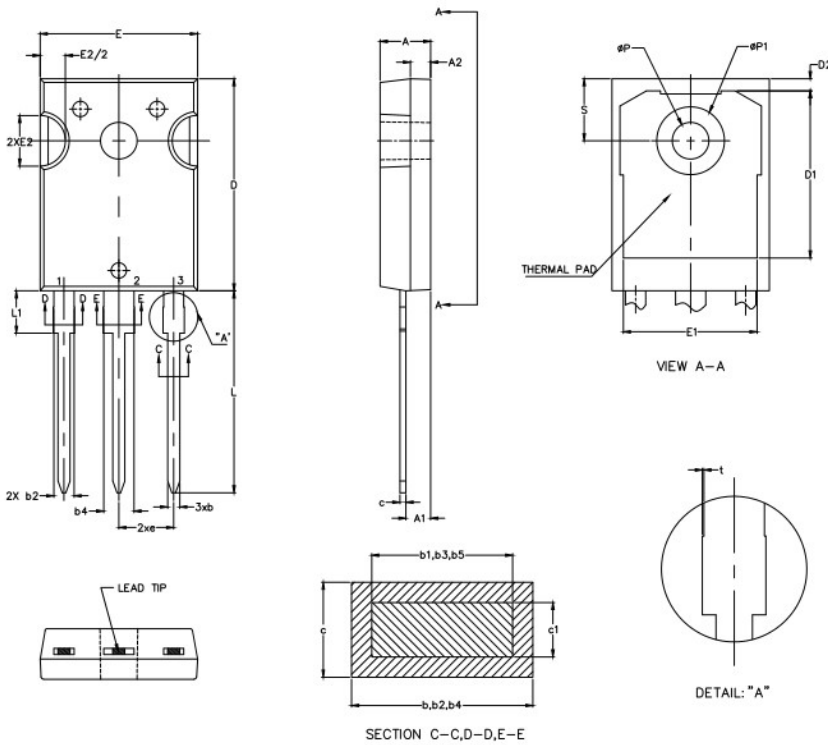

Figure 23: Clamped Inductive Switching Waveform Test Circuit

Package Dimensions

Package TO-247-3



DIMENSIONS	DIMENSIONS			
	mm		inch	
	MIN.	MAX.	MIN.	MAX.
A	4.90	5.10	0.193	0.201
A1	2.31	2.51	0.091	0.099
A2	1.90	2.10	0.075	0.083
b	1.16	1.26	0.046	0.050
b1	1.15	1.22	0.045	0.048
b2	1.96	2.06	0.077	0.081
b3	1.95	2.02	0.077	0.080
b4	2.96	3.06	0.117	0.120
b5	2.95	3.02	0.116	0.119
c	0.59	0.66	0.023	0.026
c1	0.58	0.62	0.023	0.024
D	20.90	21.10	0.823	0.831
D1	16.25	16.85	0.640	0.663
D2	1.05	1.35	0.041	0.053
E	15.75	15.90	0.620	0.626
E1	13.26	—	0.552	—
E2	4.90	5.10	0.193	0.201
e	5.44BSC		0.214BSC	
L	19.80	20.10	0.780	0.791
L1	—	4.30	—	0.169
ØP	3.50	3.70	0.138	0.146
ØP1	—	7.40	—	0.291
S	6.05	6.25	0.238	0.246
t	0.00	0.15	0.000	0.006

Revision History

Document Version	Description of Changes
Rev.1.0	Released
Rev.2.0	Static parameters at different temperatures are added

Zhejiang HIITIO New Energy Co., Ltd

ADD : NO.1125 Zhixing Road,Qiaonan District, Xiaoshan Economic and
Technological Development Zone, Hangzhou, Zhejiang

TEL :400-667-9977

