

HCS200FF120A2C1

1200V/200A Half Bridge SiC MOSFET Module

Description

The HCS200FF120A2C1 is a Half Bridge SiC MOSFET Power Module. It integrates high performance SiC MOSFET chips and SiC Diode designed for the applications such as Motor drives and Renewable energy



Features

- Blocking voltage 1200V
- $R_{ds(on)}=9.1m\Omega$
- Low thermal resistance with Si₃N₄ AMB
- 175°C maximum junction temperature
- 62mm half bridge module

Applications

- Motor Drives
- Vehicle Fast Chargers
- Renewable energy
- UPS

Circuit diagram

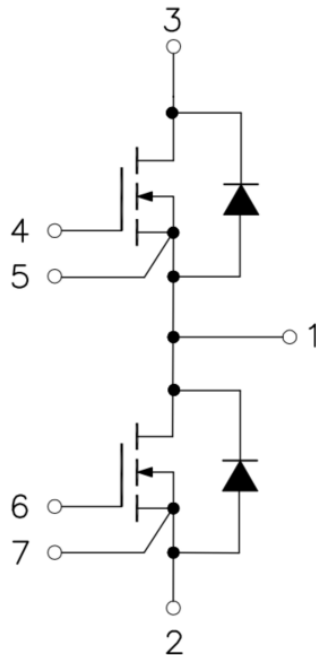

Figure 1. Out drawing & circuit diagram for HCS200FF120A2C1

HCS200FF120A2C1

1200V/200A Half Bridge SiC MOSFET Module

Pin Configuration and Marking Information

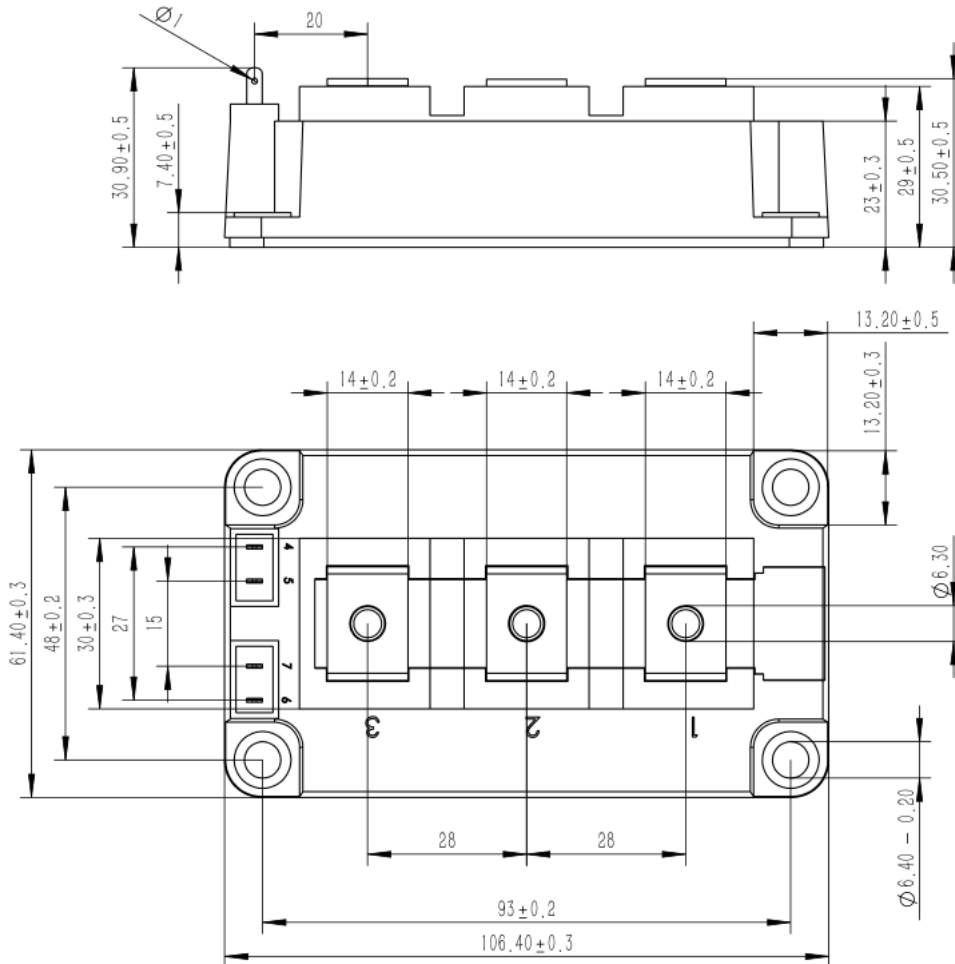

Figure 2. Pin configuration

Module

Parameter	Conditions	Value	Unit
Isolation Voltage	RMS, $f=50\text{Hz}$, $t=1\text{min}$	4.0	kV
Material of module baseplate	-	Cu	-
Creepage distance	terminal to heatsink terminal to terminal	14.5 10	mm
Clearance	terminal to heatsink terminal to terminal	12.5 10	mm
CTI	-	200	-
Module lead resistance, terminals – chip	$T_c=25^\circ\text{C}$	0.6	$\text{m}\Omega$
Mounting torque for module mounting	M6	4 to 6	Nm
Weight	-	320	g

HCS200FF120A2C1

1200V/200A Half Bridge SiC MOSFET Module

Maximum Ratings $(T_j = 25^\circ\text{C}$ unless otherwise specified)

Symbol	Parameter	Conditions	Ratings	Unit
V_{DSS}	Drain-Source Voltage	G-S Short	1200	V
V_{GSS}	Gate-Source Voltage	D-S Short, AC frequency $\geq 1\text{Hz}$, Note1	-10 to 22	V
I_{DS}	DC Continuous Drain Current	$T_C = 25^\circ\text{C}$, $V_{GS} = 18\text{V}$	245	A
I_{DS}	DC Continuous Drain Current	$T_C = 80^\circ\text{C}$, $V_{GS} = 18\text{V}$	200	A
I_{SD}	Source-Drain Current(diode)	$T_C = 25^\circ\text{C}$, with ON signal	245	A
I_{SD}	Source-Drain Current(diode)	$T_C = 80^\circ\text{C}$, with ON signal	200	A
I_{DSM}	Pulse Drain Current	$T_C = 25^\circ\text{C}$, Pulse width =1ms, $V_{GS} = 18\text{V}$, Note2	400	A
P_{tot}	Total Power Dissipation	$T_C = 25^\circ\text{C}$	785	W
T_{jmax}	Max Junction Temperature	-	175	$^\circ\text{C}$
T_{stg}	Storage Temperature	-	-40 to 125	$^\circ\text{C}$

Note1: Recommended Operating Value, +18V/-5V, +18V/-4V, +15V/-4V

Note2: Pulse width limited by maximum junction temperature

Diode Electrical characteristics $(T_j = 25^\circ\text{C}$ unless otherwise specified, chip)

Symbol	Item	Condition	Value			Unit	
			Min.	Typ.	Max		
V_F	Diode Forward Voltage	$I_F = 200\text{A}$, $V_{GS} = 0\text{V}$	$T_j = 25^\circ\text{C}$	-	1.93	-	V
			$T_j = 150^\circ\text{C}$	-	3.05	-	
t_{rr}	Diode Reverse Recovery Time	(Switch side) $V_{DD} = 600\text{V}$, $I_D = 200\text{A}$	$T_j = 25^\circ\text{C}$		29		ns
			$T_j = 150^\circ\text{C}$		31		
I_{RM}	Peak reverse recovery Current	$V_{GS} = +18\text{V}/-4\text{V}$ $R_{gon}/R_{goff} = 3.3\Omega/3.3\Omega$	$T_j = 25^\circ\text{C}$	-	83	-	A
			$T_j = 150^\circ\text{C}$	-	105	-	
Q_{rr}	Recovered charge	(FRD side) $V_{RR} = 600\text{V}$, $I_F = 200\text{A}$	$T_j = 25^\circ\text{C}$	-	1.5	-	uC
			$T_j = 150^\circ\text{C}$	-	2.1	-	
E_{rr}	Reverse recovered energy	$V_{GS} = +18\text{V}/-4\text{V}$ Inductive load switching operation	$T_j = 25^\circ\text{C}$	-	0.6	-	mJ
			$T_j = 150^\circ\text{C}$	-	1.1	-	
$R_{th(j-c)}$	Thermal Resistance, Junction to Case (Diode)		-	0.18	-	$^\circ\text{C}/\text{W}$	

HCS200FF120A2C1

1200V/200A Half Bridge SiC MOSFET Module

MOSFET Electrical characteristics (T_j=25°C unless otherwise specified, chip)

Symbol	Item	Condition	Value			Unit	
			Min.	Typ.	Max		
V _{(BR)DSS}	Drain-Source Breakdown Voltage	V _{GS} =0V, I _D =200uA	1200	-	-	V	
I _{DSS}	Zero gate voltage drain Current	V _{DS} =1200V, V _{GS} =0V	-	2	-	μA	
V _{GS(th)}	Gate-source threshold Voltage	I _D =70mA, V _{DS} =V _{GS}	T _j =25°C	1.8	2.7	-	V
			T _j =175°C	-	2.05	-	V
I _{GSS}	Gate-Source Leakage Current	V _{GS} =20V, V _{DS} =0V	T _j =25°C	-	-	200	nA
R _{DS(on)} (Chip)	Static drain-source On-state resistance	I _D =200A V _{GS} =+15V	T _j =25°C	-	10.4	-	mΩ
			T _j =175°C	-	14.4	-	mΩ
		I _D =200A V _{GS} =+18V	T _j =25°C	-	9.1	-	mΩ
			T _j =175°C	-	12.7	-	mΩ
V _{DS(on)} (Chip)	Static drain-source On-state Voltage	I _D =200A V _{GS} =+15V	T _j =25°C	-	2.08	-	V
			T _j =175°C	-	2.88	-	V
		I _D =200A V _{GS} =+18V	T _j =25°C	-	1.82	-	V
			T _j =175°C	-	2.54	-	V
C _{iss}	Input Capacitance	V _D =800V, V _{GS} =0V, f =100kHz, V _{AC} =25mV	-	11628	-	pF	
C _{oss}	Output Capacitance		-	354	-	pF	
C _{rss}	Reverse transfer Capacitance		-	29	-	pF	
R _{Gint}	Internal gate resistor	f =100kHz, V _{AC} =25mV	-	3.2	-	Ω	
Q _g	Total gate charge	V _{DD} =800V, I _D =120A, V _{GS} =+18/-4V	-	420	-	nC	
t _{d(on)}	Turn-on delay time	V _{DD} =600V I _D =200A V _{GS} =+18/-4V R _{gon} /R _{goff} =3.3Ω/3.3Ω Inductive load switching operation	T _j =25°C	-	75	-	ns
			T _j =150°C	-	71	-	
t _r	Rise time		T _j =25°C	-	48	-	ns
			T _j =150°C	-	43	-	
t _{d(off)}	Turn-off delay time		T _j =25°C	-	162	-	ns
			T _j =150°C	-	189	-	
t _f	Fall time		T _j =25°C	-	49	-	ns
			T _j =150°C	-	55	-	
E _{on}	Turn-on power dissipation		T _j =25°C	-	3.6	-	mJ
			T _j =150°C	-	2.5	-	
E _{off}	Turn-off power dissipation	T _j =25°C	-	4.6	-	mJ	
		T _j =150°C	-	5.1	-		
R _{th(j-c)}	FET Thermal Resistance	Junction to Case	-	0.19	-	°C/W	

HCS200FF120A2C1

1200V/200A Half Bridge SiC MOSFET Module

Test Conditions

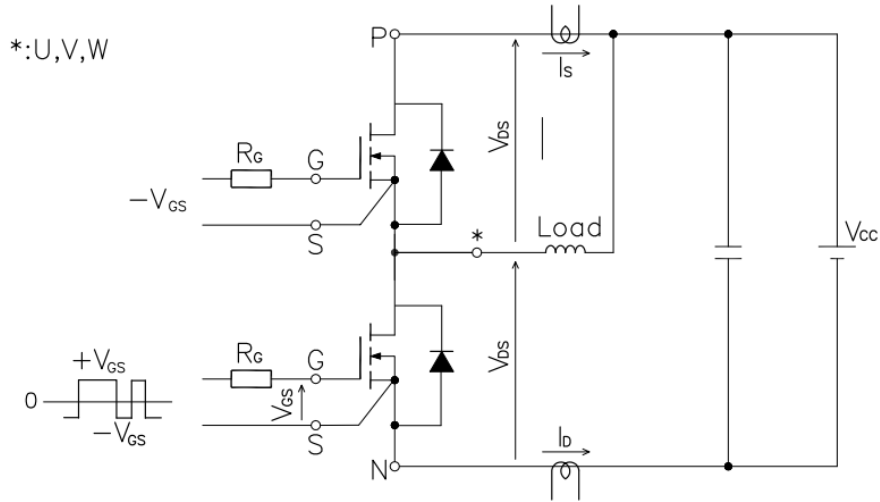

Figure 3. Switching time measure circuit

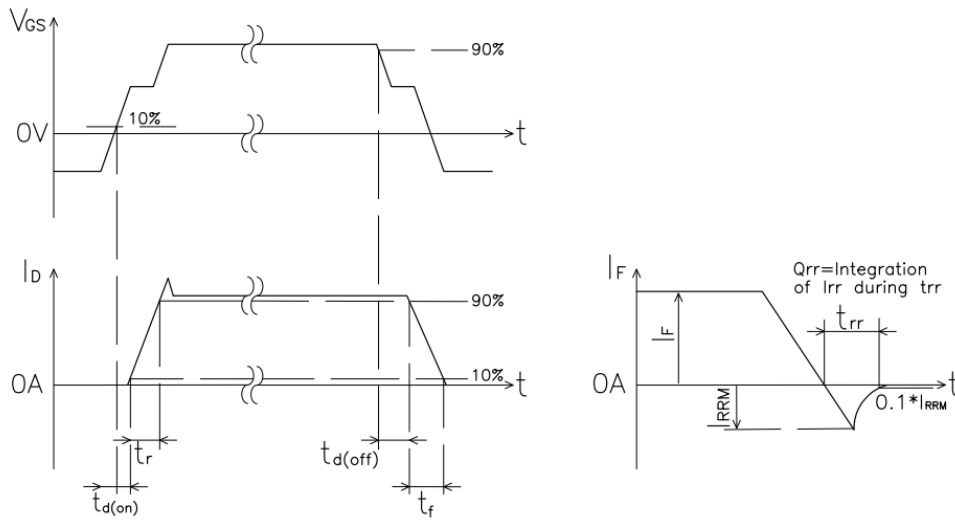

Figure 4. Switching time definition

HCS200FF120A2C1

1200V/200A Half Bridge SiC MOSFET Module

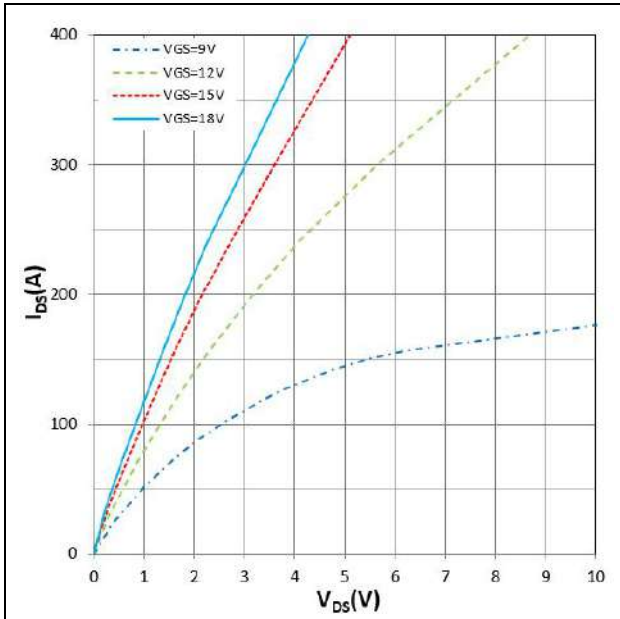

Figure 5. I_{DS} vs V_{DS}
 $T_j = 25^\circ\text{C}$

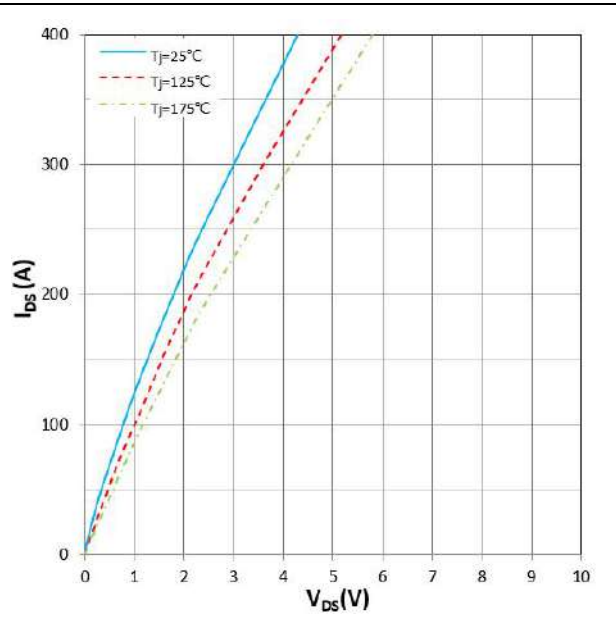

Figure 6. I_{DS} vs V_{DS}
 $V_{GS} = +18\text{V}$

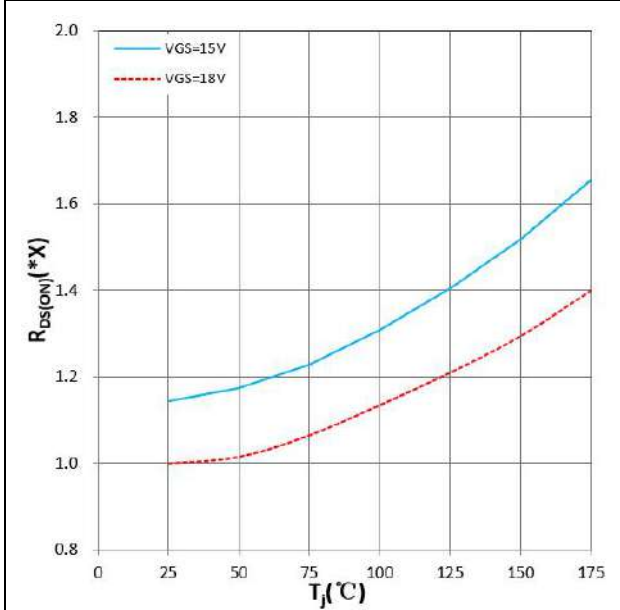

Figure 7. $R_{DS(ON)}$ vs T_j
 $V_{GS} = +15\text{V}/+18\text{V}$, $I_D = 200\text{A}$, $1.0X = 9.1\text{m}\Omega$

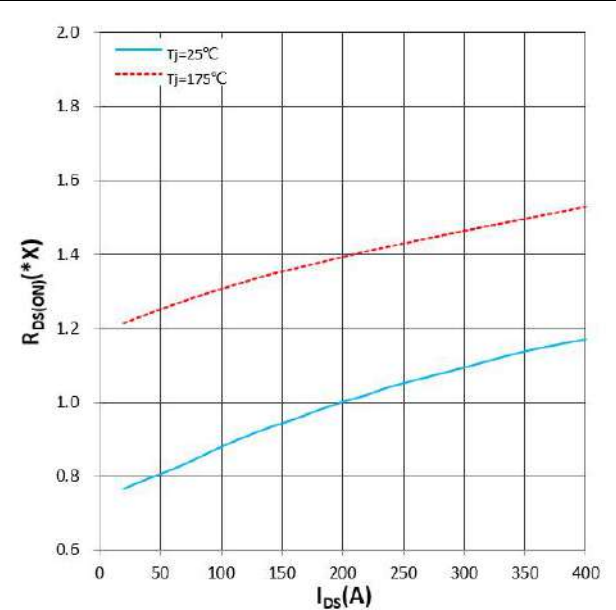

Figure 8. $R_{DS(ON)}$ vs I_{DS}
 $V_{GS} = +18\text{V}$, $1.0X = 9.1\text{m}\Omega$

HCS200FF120A2C1

1200V/200A Half Bridge SiC MOSFET Module

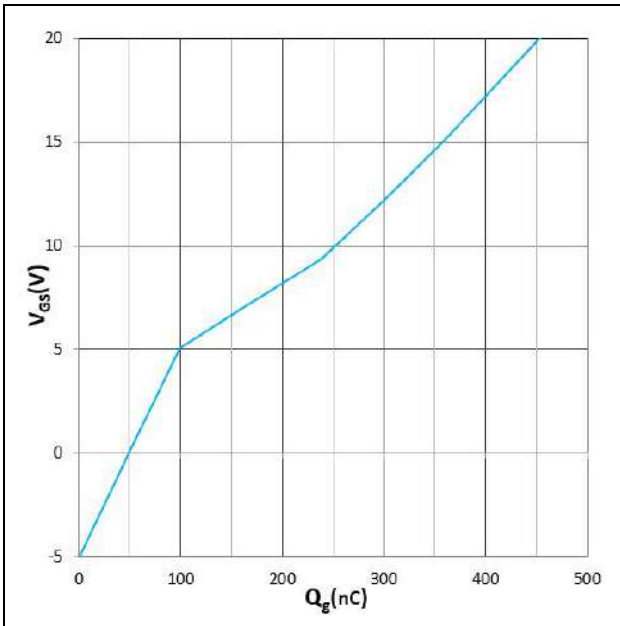

Figure 9. V_{GS} vs Q_g
 $V_{DS} = 800V, I_D = 120A, T_j = 25^\circ C$

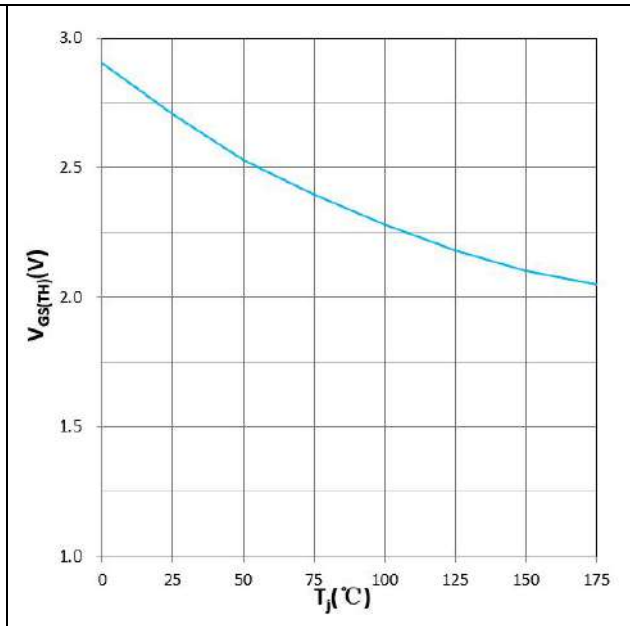

Figure 10. $V_{GS(TH)}$ vs T_j
 $V_{GS} = V_{DS}, I_D = 70mA$

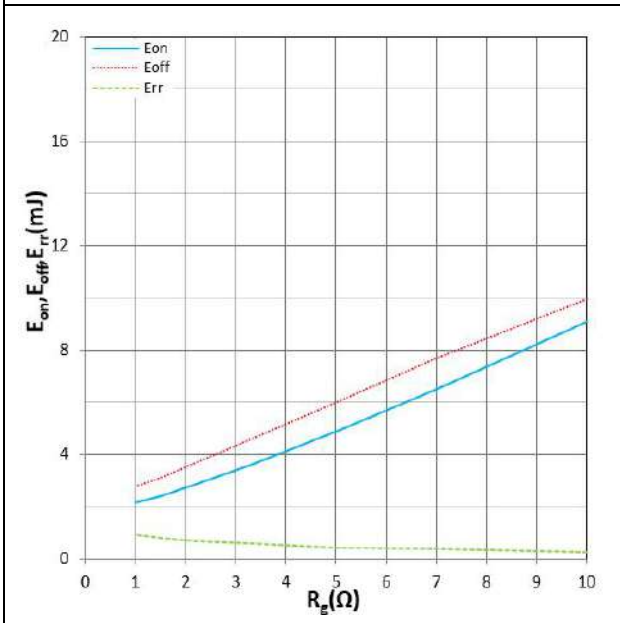

Figure 11. E_{on}, E_{off}, E_{rr} vs R_g
 $T_j = 25^\circ C, V_{DD} = 600V, V_{GS} = +18V/-4V, I_D = 200A$
 Inductive Load

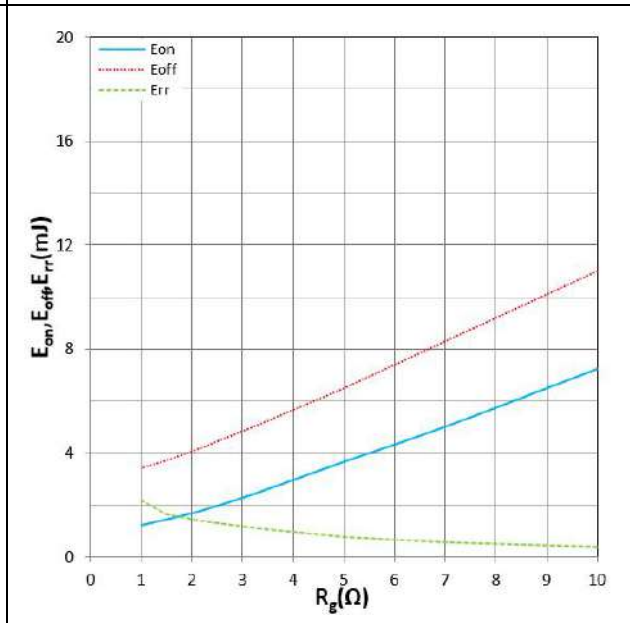

Figure 12. E_{on}, E_{off}, E_{rr} vs R_g
 $T_j = 150^\circ C, V_{DD} = 600V, V_{GS} = +18V/-4V, I_D = 200A$
 Inductive Load

HCS200FF120A2C1

1200V/200A Half Bridge SiC MOSFET Module

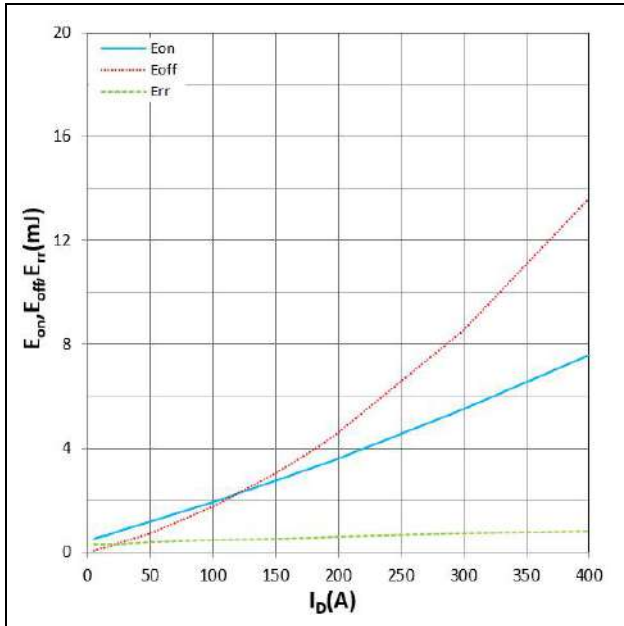

Figure 13. E_{on}, E_{off}, E_{rr} vs I_{DS}

T_j=25°C, V_{DD}=600V, V_{GS}=+18V/-4V

R_{gon}/R_{goff}=3.3Ω/3.3Ω, Inductive Load

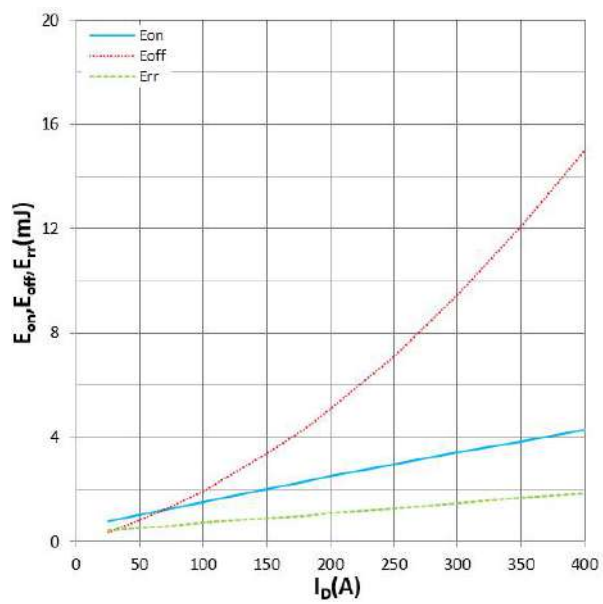

Figure 14. E_{on}, E_{off}, E_{rr} vs I_{DS}

T_j=150°C, V_{DD}=600V, V_{GS}=+18V/-4V

R_{gon}/R_{goff}=3.3Ω/3.3Ω, Inductive Load

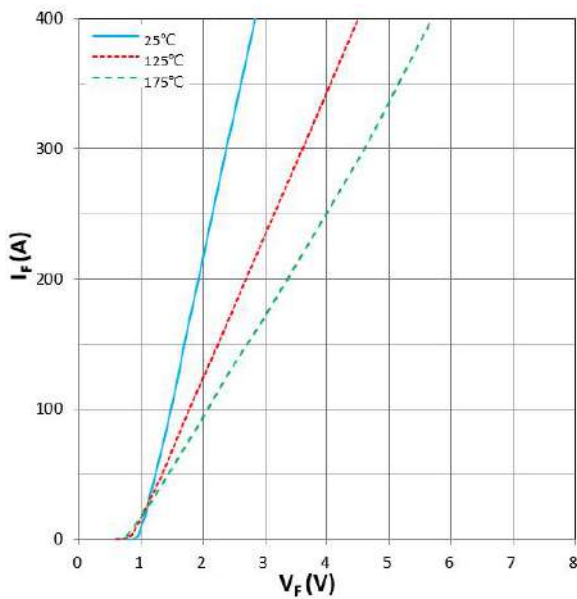

Figure 15. I_F vs V_F

V_{GS}=0V

HCS200FF120A2C1

1200V/200A Half Bridge SiC MOSFET Module

IMPORTANT NOTICE

This product data sheet describes the characteristics of this product for which a warranty is granted. Any such warranty is granted exclusively under the terms and conditions of the supply agreement. There will be no guarantee or of any kind for the product and its characteristics.

The data contained in this document is exclusively intended for technically trained staff. You and your technical departments will have to evaluate the product's suitability for the intended application and the completeness of the product data concerning such application.

Due to technical requirements, our product may contain dangerous substances. For information on the types in question, please contact the sales staff responsible for you.

Changes to this product data sheet are reserved.

Please contact the sales staff (sales@hiitio.com) for further information on the product, technology, delivery terms, conditions and prices.