

HCG100PM120E7D1

1200V/100A PIM IGBT Module

Description

The HCG100PM120E7D1 offer lower losses and higher energy for application such as motor drive, inverter and other soft switching applications



Features

- 1200V100A,VCE (sat)(typ.) = 2.10V
- Lower losses and higher energy
- Excellent short circuit ruggedness
- PIM module

Applications

- Inverter
- Power supply
- Motion/servo control

Circuit diagram

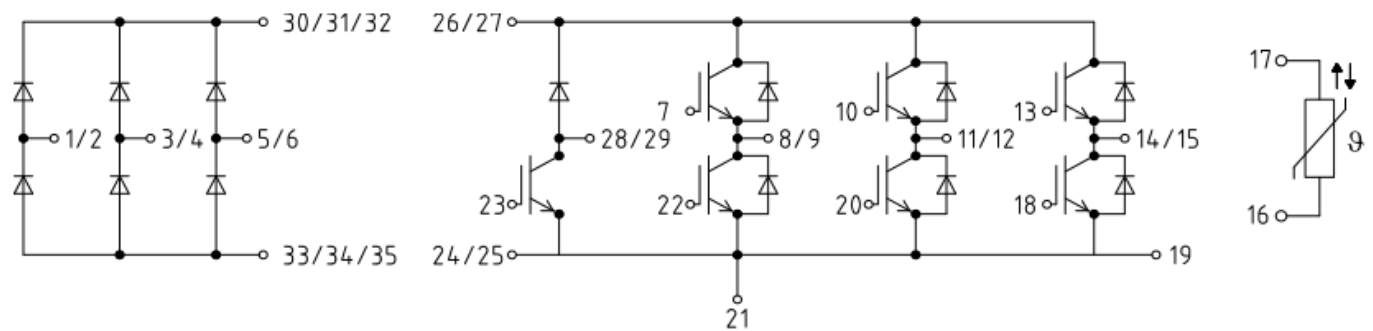

Figure 1. Outdrawing & circuit diagram for HCG100PM120E7D1

HCG100PM120E7D1

1200V/100A PIM IGBT Module

Pin Configuration and Marking Information

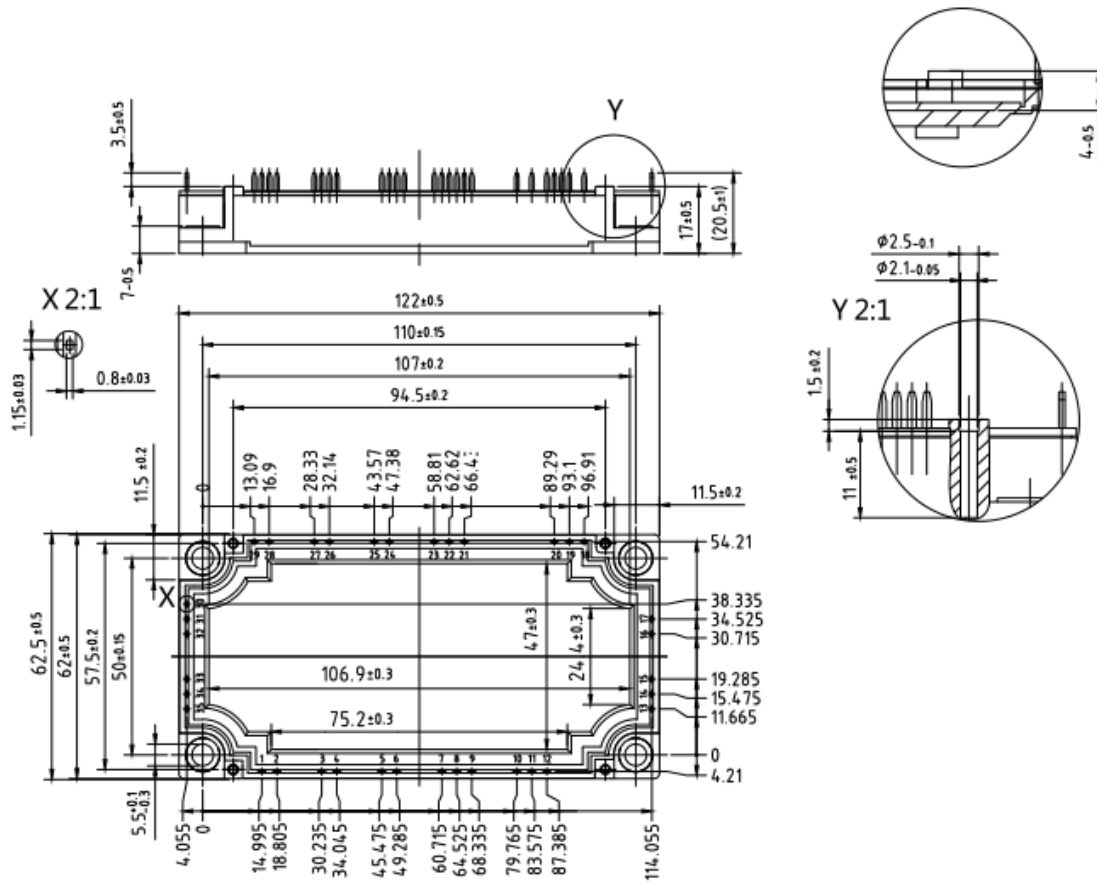

Figure 2. Pin configuration

Module

Parameter	Conditions	Value	Unit
Isolation Voltage	RMS, f =50Hz, t =1 min	2.5	KV
Material of module baseplate	-	Cu	-
Creepage distance	terminal to heatsink terminal to terminal	17 3.81	mm
Clearance	terminal to heatsink terminal to terminal	17 3.81	mm
CTI	-	>200	-
Module lead resistance, terminals – chip	T _c =25°C	0.8	mΩ
Mounting torque for module mounting	M5	3 to 6	Nm
Weight	-	300	g

HCG100PM120E7D1

1200V/100A PIM IGBT Module

Maximum Ratings (IGBT, $T_j=25^{\circ}\text{C}$ unless otherwise specified)

Symbol	Parameter	Conditions	Ratings	Unit
V_{CES}	Collector-Emitter Voltage	G-E Short	1200	V
V_{RRM}	Peak Repetitive Revers Voltage	-	1200	V
V_{GES}	Gate-Emitter Voltage	C-E Short	$\pm 30\text{V}$	V
I_C	DC Continuous Collector Current	$T_C=100^{\circ}\text{C}$	100	A
I_{CM}	Pulse Collector Current	$t_p=1\text{ms}$, Note1	200	A
P_C	Maximum Power Dissipation		670	W
T_j	junction temperature	-	-40 to 150	$^{\circ}\text{C}$
T_{stg}	Storage temperature	-	-40 to 125	$^{\circ}\text{C}$

Note1: Pulse width limited by maximum junction temperature

Maximum Ratings (Freewheeling diode, $T_j=25^{\circ}\text{C}$ unless otherwise specified)

Symbol	Parameter	Conditions	Ratings	Unit
V_{RRM}	Peak Repetitive Revers Voltage	-	1200	V
I_F	Diode forward Current	-	100	A
I_{FRM}	Repetitive peak forward Current	$t_p=1\text{ms}$, Note1	200	A
T_j	junction temperature	-	-40 to 150	$^{\circ}\text{C}$
T_{stg}	Storage temperature	-	-40 to 125	$^{\circ}\text{C}$

Note1: Pulse width limited by maximum junction temperature

Maximum Ratings (IGBT, Brake-chopper, $T_j=25^{\circ}\text{C}$ unless otherwise specified)

Symbol	Parameter	Conditions	Ratings	Unit
V_{CES}	Collector-Emitter Voltage	G-E Short	1200	V
V_{RRM}	Peak Repetitive Revers Voltage	-	1200	V
V_{GES}	Gate-Emitter Voltage	C-E Short	$\pm 30\text{V}$	V
I_C	DC Continuous Collector Current	$T_C=100^{\circ}\text{C}$	50	A
I_{CM}	Pulse Collector Current	$t_p=1\text{ms}$, Note1	100	A
P_C	Maximum Power Dissipation		365	W
T_j	junction temperature	-	-40 to 150	$^{\circ}\text{C}$
T_{stg}	Storage temperature	-	-40 to 125	$^{\circ}\text{C}$

Note1: Pulse width limited by maximum junction temperature

Maximum Ratings (diode, Brake-chopper, $T_j=25^{\circ}\text{C}$ unless otherwise specified)

Symbol	Parameter	Conditions	Ratings	Unit
V_{RRM}	Peak Repetitive Revers Voltage	-	1200	V
I_F	Diode forward Current	-	50	A
I_{FRM}	Repetitive peak forward Current	$t_p=1\text{ms}$, Note1	100	A
T_j	junction temperature	-	-40 to 150	$^{\circ}\text{C}$
T_{stg}	Storage temperature	-	-40 to 125	$^{\circ}\text{C}$

Note1: Pulse width limited by maximum junction temperature

HCG100PM120E7D1

1200V/100A PIM IGBT Module

NTC characteristics

Symbol	Parameter	Condition	Value			Unit
			Min.	Typ.	Max.	
R ₂₅	Resistance	T _C =25°C	-	5	-	kΩ
R/R	Deviation of R ₁₀₀	T _C =100°C, R ₁₀₀ =493Ω	-5	-	5	%
P ₂₅	Power dissipation	T _C =25°C	-	-	20	mW
B _{25/50}	B-value	$R_2 = R_{25} \exp [B_{25/50}(1/T_2 - 1/(298,15 K))]$	-	3375	-	K
B _{25/80}	B-value	$R_2 = R_{25} \exp [B_{25/80}(1/T_2 - 1/(298,15 K))]$	-	3410	-	K
B _{25/100}	B-value	$R_2 = R_{25} \exp [B_{25/100}(1/T_2 - 1/(298,15 K))]$	-	3433	-	K

IGBT Electrical characteristics (T_j=25°C unless otherwise specified, chip)

Symbol	Item	Condition	Value			Unit	
			Min.	Typ.	Max		
V _{CE(sat)} (Chip)	Collector-Emitter Saturation Voltage	I _C =100A	-	T _j =25°C	2.1	2.3	V
		V _{GE} =15V		T _j =125°C	2.5	-	V
V _{GE(th)}	Gate-Emitter threshold Voltage	I _C =1mA, V _{CE} =V _{GE}	4.5	-	5.5	V	
Q _G	Gate charge	V _{GE} =-15V to +15V	-	1000	-	nC	
R _{Gint}	Internal gate resistor	f=1M, V _{pp} =1V	-	1.9	-	Ω	
C _{ies}	Input Capacitance	V _{CE} =25V, V _{GE} =0V f=1MHz	-	8.00	-	nF	
C _{oes}	Output Capacitance		-	1.35	-	nF	
C _{res}	Reverse transfer Capacitance		-	0.81	-	nF	
I _{CES}	Collector- Emitter Cut off Current	V _{CE} =1200V, V _{GE} =0V	-	-	1	mA	
I _{GES}	Gate-Emitter Leakage Current	V _{GE} =30V, V _{CE} =0V	-	-	200	nA	
t _{d(on)}	Turn-on delay time	V _{CC} =600V I _C =100A V _{GE} =+15V/-15V R _G =5.6Ω Inductive load	T _j =25°C	-	90	-	ns
			T _j =125°C	-	100	-	ns
t _r	Rise time		T _j =25°C	-	60	-	ns
			T _j =125°C	-	65	-	ns
t _{d(off)}	Turn-off delay time		T _j =25°C	-	460	-	ns
			T _j =125°C	-	470	-	ns
t _f	Fall time		T _j =25°C	-	220	-	ns
			T _j =125°C	-	300	-	ns
E _{on}	Turn-on power dissipation		T _j =25°C	-	5.3	-	mJ
			T _j =125°C	-	5.8	-	mJ
E _{off}	Turn-off power dissipation		T _j =25°C	-	7.1	-	mJ
			T _j =125°C	-	9.0	-	mJ
R _{th(j-c)}	Thermal Resistance, Junction to Case (IGBT)		-		-0.186	°C/W	

HCG100PM120E7D1

1200V/100A PIM IGBT Module

Freewheeling Diode Electrical characteristics ($T_j=25^\circ\text{C}$ unless otherwise specified, chip)

Symbol	Item	Condition		Value			Unit
				Min.	Typ.	Max	
V_F	Diode Forward Voltage	$I_F=100\text{A}, V_{GE}=0\text{V}$	$T_j=25^\circ\text{C}$	-	1.90	2.2	V
			$T_j=125^\circ\text{C}$	-	1.9	-	
t_{rr}	Reverse recovery time	(Switch side) $V_{rr}=600\text{V}, I_F=100\text{A}$ $di/dt=1500\text{A}/\mu\text{s}$	$T_j=25^\circ\text{C}$	-	120	-	ns
			$T_j=125^\circ\text{C}$	-	145	-	
I_{rr}	Peak reverse recovery Current		$T_j=25^\circ\text{C}$	-	90	-	A
			$T_j=125^\circ\text{C}$	-	110	-	
Q_{rr}	Recovered charge		$T_j=25^\circ\text{C}$	-	6.5	-	uC
			$T_j=125^\circ\text{C}$	-	8.7	-	
E_{rr}	Reverse recovered energy		$T_j=25^\circ\text{C}$	-	1.8	-	mJ
			$T_j=125^\circ\text{C}$	-	2.5	-	
$R_{th(j-c)}$	Thermal Resistance, Junction to Case (Diode)			-		0.301	$^\circ\text{C}/\text{W}$

IGBT, Brake - chopper Electrical characteristics ($T_j=25^\circ\text{C}$ unless otherwise specified, chip)

Symbol	Item	Condition		Value			Unit	
				Min.	Typ.	Max		
$V_{CE(sat)}$ (Chip)	Collector-Emitter Saturation Voltage	$I_C=50\text{A}$ $V_{GE}=15\text{V}$	$T_j=25^\circ\text{C}$	-	2.1	2.3	V	
			$T_j=125^\circ\text{C}$	-	2.5	-	V	
$V_{GE(th)}$	Gate-Emitter threshold Voltage	$I_C=1\text{mA}, V_{CE}=V_{GE}$		4.5	-	5.7	V	
Q_G	Gate charge	$V_{GE}=-15\text{V to }+15\text{V}$		-	430	-	nC	
R_{Gint}	Internal gate resistor	$f=1\text{M}, V_{pp}=1\text{V}$	$T_j=25^\circ\text{C}$	-	2.2	-	Ω	
C_{ies}	Input Capacitance	$V_{CE}=25\text{V}, V_{GE}=0\text{V}$ $f=1\text{MHz}$	$T_j=25^\circ\text{C}$	-	3.80	-	nF	
C_{oes}	Output Capacitance			-	0.51	-	nF	
C_{res}	Reverse transfer Capacitance			-	0.33	-	nF	
I_{CES}	Collector- Emitter Cut off Current	$V_{CE}=1200\text{V}, V_{GE}=0\text{V}$		$T_j=25^\circ\text{C}$	-	-	1	mA
I_{GES}	Gate-Emitter Leakage Current	$V_{GE}=30\text{V}, V_{CE}=0\text{V}$		$T_j=25^\circ\text{C}$	-	-	200	nA
$t_{d(on)}$	Turn-on delay time	$V_{CC}=600\text{V}$ $I_C=50\text{A}$ $V_{GE}=+15\text{V}/-15\text{V}$ $R_G=5.6\Omega$ Inductive load	$T_j=25^\circ\text{C}$	-	20	-	ns	
			$T_j=125^\circ\text{C}$	-	25	-		
t_r	Rise time		$T_j=25^\circ\text{C}$	-	40	-	ns	
			$T_j=125^\circ\text{C}$	-	45	-		
$t_{d(off)}$	Turn-off delay time		$T_j=25^\circ\text{C}$	-	300	-	ns	
			$T_j=125^\circ\text{C}$	-	330	-		
t_f	Fall time		$T_j=25^\circ\text{C}$	-	160	-	ns	
			$T_j=125^\circ\text{C}$	-	180	-		
E_{on}	Turn-on power dissipation		$T_j=25^\circ\text{C}$	-	4.5	-	mJ	
			$T_j=125^\circ\text{C}$	-	6.5	-		
E_{off}	Turn-off power dissipation		$T_j=25^\circ\text{C}$	-	4.2	-	mJ	

HCG100PM120E7D1

1200V/100A PIM IGBT Module

			$T_j=125^\circ\text{C}$	-	6.1	-	
$R_{th(j-c)}$	Thermal Resistance, Junction to Case (IGBT)			-		0.343	$^\circ\text{C/W}$

Diode , Brake -chopper Electrical characteristics ($T_j=25^\circ\text{C}$ unless otherwise specified, chip)

Symbol	Item	Condition	Value			Unit	
			Min.	Typ.	Max		
V_F	Diode Forward Voltage	$I_F=50\text{A}, V_{GE}=0\text{V}$	$T_j=25^\circ\text{C}$	-	1.90	2.2	V
			$T_j=125^\circ\text{C}$	-	1.9	-	
t_{rr}	Reverse recovery time		$T_j=25^\circ\text{C}$	-	110	-	ns
			$T_j=125^\circ\text{C}$	-	250	-	
I_{rr}	Peak reverse recovery Current	(Switch side) $V_{rr}=600\text{V}, I_F=50\text{A}$ $di/dt=1500\text{A}/\mu\text{s}$	$T_j=25^\circ\text{C}$	-	85	-	A
			$T_j=125^\circ\text{C}$	-	100	-	
Q_{rr}	Recovered charge		$T_j=25^\circ\text{C}$	-	5.5	-	uC
			$T_j=125^\circ\text{C}$	-	9.5	-	
E_{rr}	Reverse recovered energy		$T_j=25^\circ\text{C}$	-	1.8	-	mJ
			$T_j=125^\circ\text{C}$	-	3.7	-	
$R_{th(j-c)}$	Thermal Resistance, Junction to Case (Diode)			-		0.652	$^\circ\text{C/W}$

Maximum Ratings (Rectifier diode, $T_j=25^\circ\text{C}$ unless otherwise specified)

Symbol	Parameter	Conditions	Ratings	Unit
V_{RRM}	Peak Repetitive Revers Voltage	$T_j=25^\circ\text{C}$	1800	V
I_{FRMSM}	Maximum RMS forward current per chip	$T_c=80^\circ\text{C}$	100	A
I_{RMSM}	Maximum RMS current at rectifier output	$T_c=80^\circ\text{C}$	200	A
I_{FSM}	Surge Current @ $t_p=10\text{ms}$	$T_j=25^\circ\text{C}$	1080	A
I^2t	I^2t - value	$T_j=25^\circ\text{C}$	5832	A^2s
T_j	junction temperature	-	-40 to 150	$^\circ\text{C}$
T_{stg}	Storage temperature	-	-40 to 125	$^\circ\text{C}$

Note1: Pulse width limited by maximum junction temperature

RectifierDiodeElectrical characteristics ($T_j=25^\circ\text{C}$ unless otherwise specified, chip)

Symbol	Item	Condition	Value			Unit	
			Min.	Typ.	Max		
V_F	Diode Forward Voltage	$I_F=100\text{A}$	$T_j=25^\circ\text{C}$		1.05	V	
			$T_j=125^\circ\text{C}$		0.85		
I_R	Reverse current		$T_j=125^\circ\text{C}$		1.0	mA	
$R_{\theta JC}$	Thermal Resistance, Junction-to-Case (Diode)					0.40	$^\circ\text{C/W}$

HCG100PM120E7D1
1200V/100A PIM IGBT Module

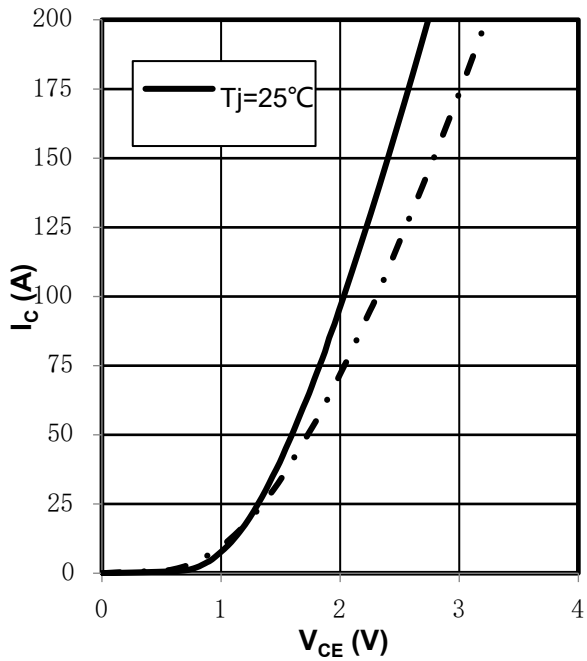

Fig 1. output characteristic IGBT,
 $I_c=f(V_{CE}), V_{GE}=15V$

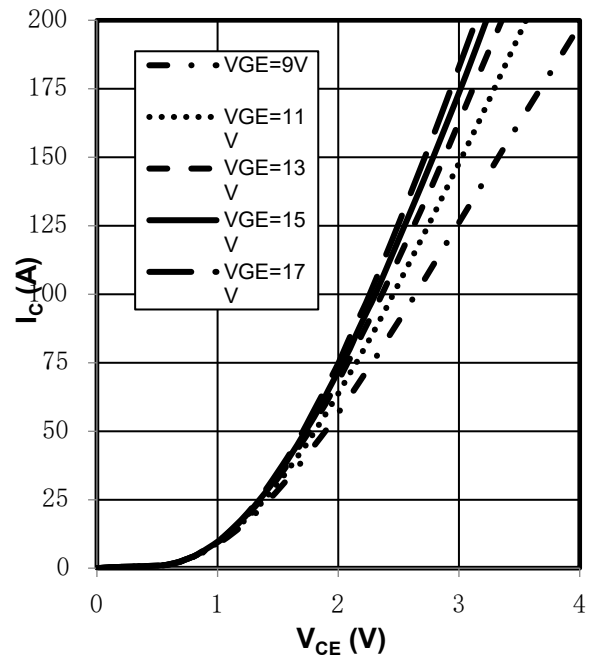

Fig 2. output characteristic IGBT,
 $I_c=f(V_{CE}), T_j=125^\circ C$

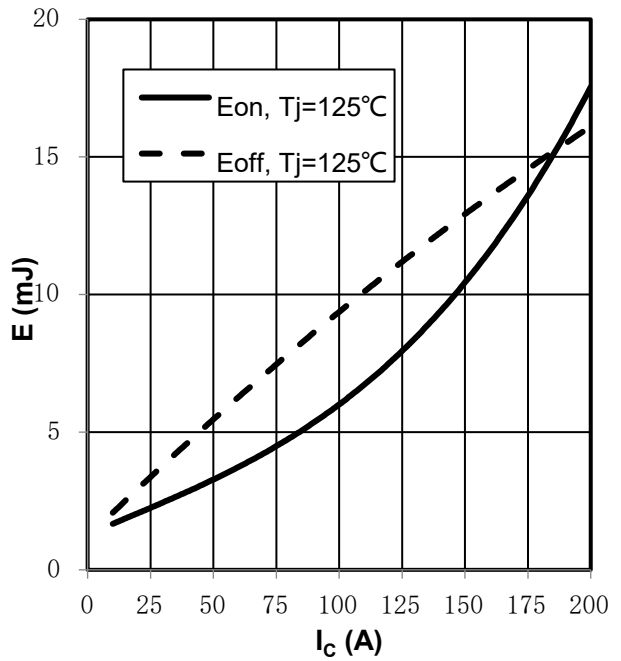

Fig 3. transfer characteristic IGBT,
 $I_c=f(V_{GE}), V_{CE}=20V$

Fig 4. switching losses IGBT,
 $E_{on}=f(I_c), E_{off}=f(I_c)$

HCG100PM120E7D1
1200V/100A PIM IGBT Module

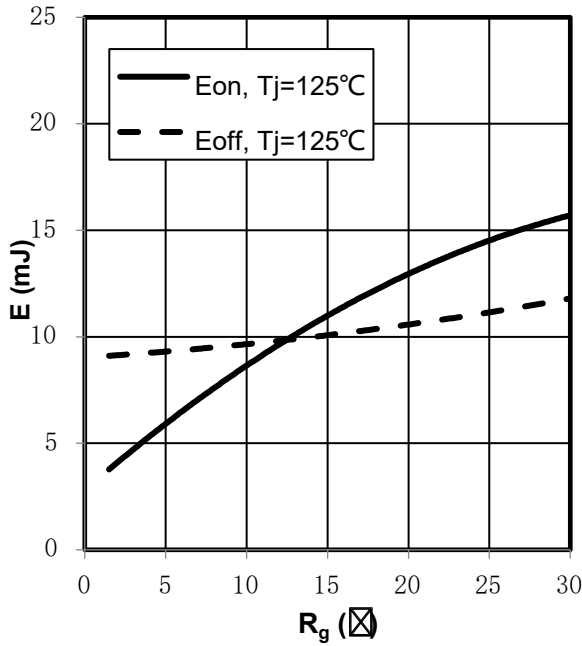

Fig 5. switching losses IGBT, $E_{on}=f(R_g), E_{off}=f(R_g)$,
 $V_{GE}=\pm 15V, I_c=100A, V_{CE}=600V$

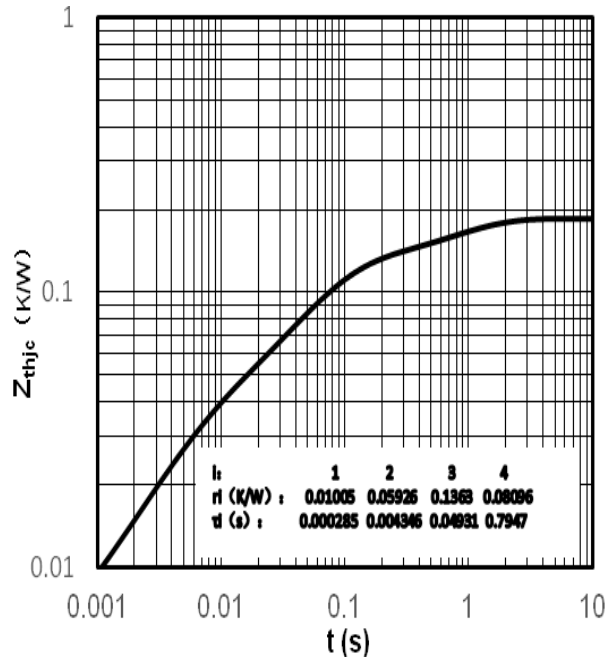

Fig 6. transient thermal impedance IGBT ,
 $Z_{thjc}=f(t)$

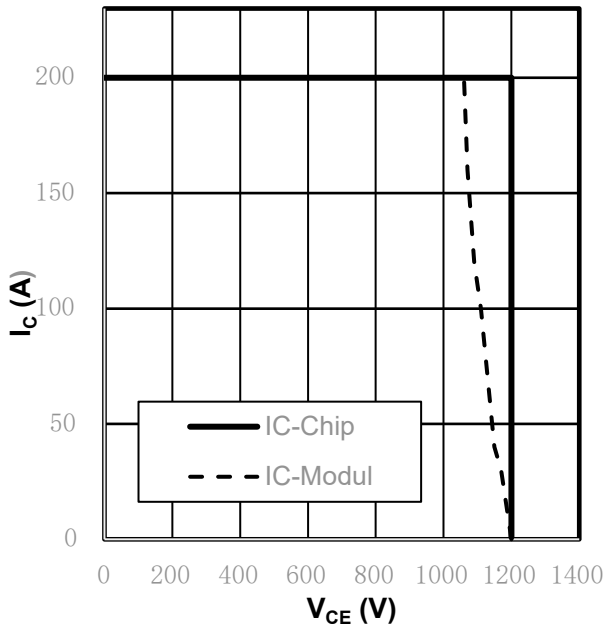

Fig 7. reverse bias safe operating area IGBT,
 $I_c=f(V_{CE}), V_{GE}=\pm 15V, R_{Goff}=5.6\Omega, T_{vj}=125^\circ C$

Fig 8. forward characteristic of Diode ,
 $I_F=f(V_F)$

HCG100PM120E7D1
1200V/100A PIM IGBT Module

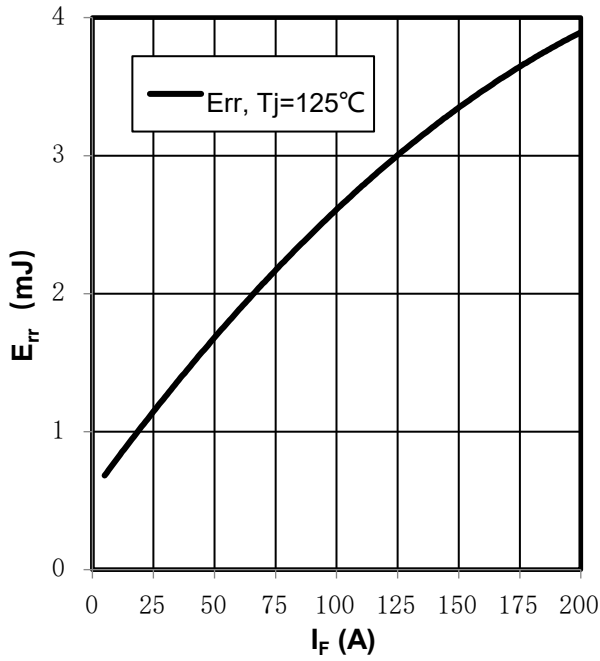

Fig9. switching losses Diode,
 $E_{rr}=f(I_F), R_{Gon}=5.6\Omega, V_{CE}=600V$

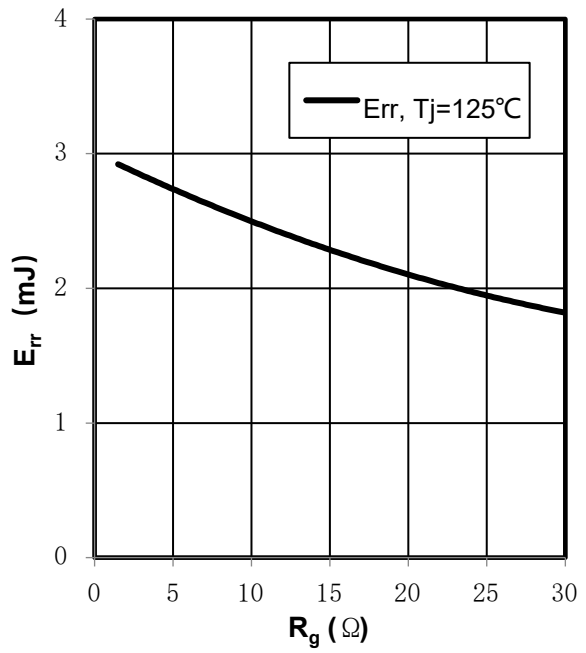

Fig 10. switching losses Diode,
 $E_{rr}=f(R_g), I_F=100A, V_{CE}=600V$

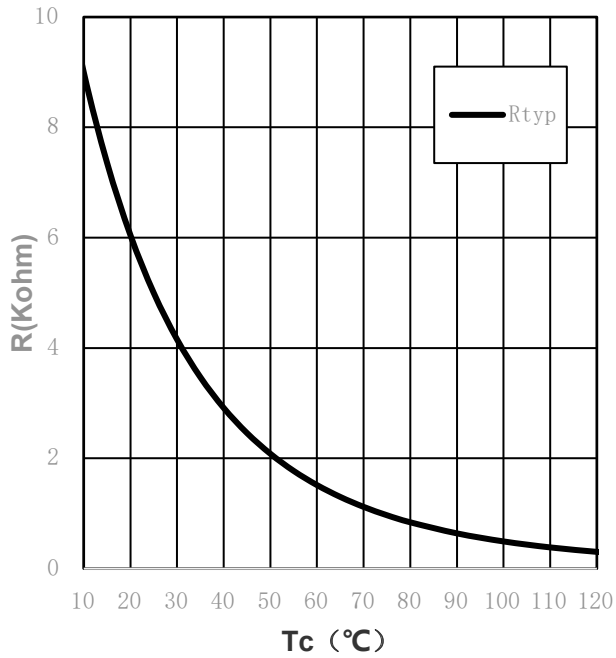

Fig11.NTC-Thermistor-temperature characteristic(typical)

HCG100PM120E7D1

1200V/100A PIM IGBT Module

IMPORTANT NOTICE :

This product data sheet describes the characteristics of this product for which a warranty is granted. Any such warranty is granted exclusively under the terms and conditions of the supply agreement. There will be no guarantee or of any kind for the product and its characteristics.

The data contained in this document is exclusively intended for technically trained staff. You and your technical departments will have to evaluate the product's suitability for the intended application and the completeness of the product data concerning such application.

Due to technical requirements, our product may contain dangerous substances. For information on the types in question, please contact the sales staff responsible for you.

Changes to this product data sheet are reserved.

Please contact the sales staff (Email:sales@hiitio.com) for further information on the product, technology, delivery terms, conditions and prices.

Instruction note

Naming rules for power module product models (Industrial module)

Product Model																																							
	HC	G	100	FF	120	E3	A																																
Hecheng Code																																							
Module type G : IGBT module D : FRD module S : SiC module H : Si/SiC hybrid																																							
Current level (A) 50~900																																							
Topology structure FZ : A switch unit FF : Half bridge FS : Three phase F4 : H Bridge F3L : Three level DF : Boost Circuit FD : Braking Circuit FP : Rectification+Inverter+Control move AL : ANPC CL : Chopper																																							
Voltage level (x10) (V) 650~2200																																							
Packaging form+features (A...Z) <table border="0"> <tr> <td>A1 : 34 mm</td> <td>A2 : 62 mm</td> <td></td> <td></td> </tr> <tr> <td>B1 : Easy 1B</td> <td>B1A</td> <td>B1B...</td> <td></td> </tr> <tr> <td>B2 : Easy 2B...</td> <td>B3 : Easy 3B...</td> <td></td> <td></td> </tr> <tr> <td>D1 : Flow0</td> <td>D2 : Flow1</td> <td>D3 : Flow2</td> <td></td> </tr> <tr> <td>E0 : E0</td> <td>E1 : Econo 2...</td> <td>E2 : E2</td> <td></td> </tr> <tr> <td>E3 : ED3</td> <td>E4 : E4</td> <td>E5 : ED3S</td> <td></td> </tr> <tr> <td>E6 : EPM2</td> <td>E7 : EPM3</td> <td>E8 : EconoPIM3</td> <td></td> </tr> <tr> <td>E9 : ED3H</td> <td>F0 : F0</td> <td>P2 : EPM2</td> <td></td> </tr> </table>								A1 : 34 mm	A2 : 62 mm			B1 : Easy 1B	B1A	B1B...		B2 : Easy 2B...	B3 : Easy 3B...			D1 : Flow0	D2 : Flow1	D3 : Flow2		E0 : E0	E1 : Econo 2...	E2 : E2		E3 : ED3	E4 : E4	E5 : ED3S		E6 : EPM2	E7 : EPM3	E8 : EconoPIM3		E9 : ED3H	F0 : F0	P2 : EPM2	
A1 : 34 mm	A2 : 62 mm																																						
B1 : Easy 1B	B1A	B1B...																																					
B2 : Easy 2B...	B3 : Easy 3B...																																						
D1 : Flow0	D2 : Flow1	D3 : Flow2																																					
E0 : E0	E1 : Econo 2...	E2 : E2																																					
E3 : ED3	E4 : E4	E5 : ED3S																																					
E6 : EPM2	E7 : EPM3	E8 : EconoPIM3																																					
E9 : ED3H	F0 : F0	P2 : EPM2																																					
Feature :A: Special Code Nil: Standard																																							

Zhejiang HIITIO New Energy Co., Ltd

ADD : NO.1125 Zhixing Road,Qiaonan District, Xiaoshan Economic and Technological Development Zone, Hangzhou, Zhejiang

TEL :400-667-9977

