

HCG150FF120A11

1200V/150A Half Bridge IGBT Module

Description

The HCG150FF120A11 offer ultrafast switching speed for high frequency application.



Features

- 1200V150 A, VCE (sat)(typ.) = 2.30V
- Lower losses
- SPT (Soft Punch Through) technology
- Excellent short-circuit capability
- 34 mm half bridge module

Applications

- Welding
- Motor drive
- Inductiveheating
- Power supply
- UPS / EPS

Circuit diagram

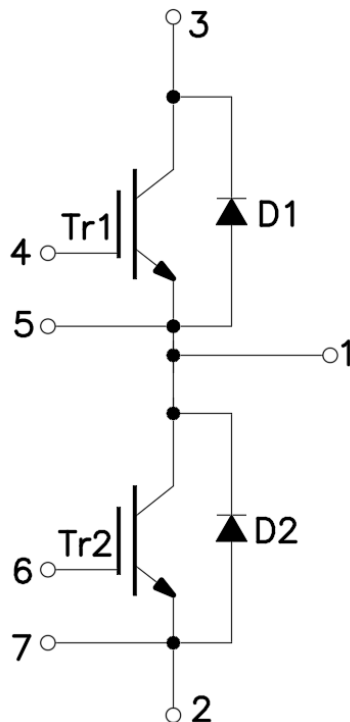

Figure 1. Out drawing & circuit diagram for HCG150FF120A11

HCG150FF120A11

1200V/150A Half Bridge IGBT Module

Pin Configuration and Marking Information

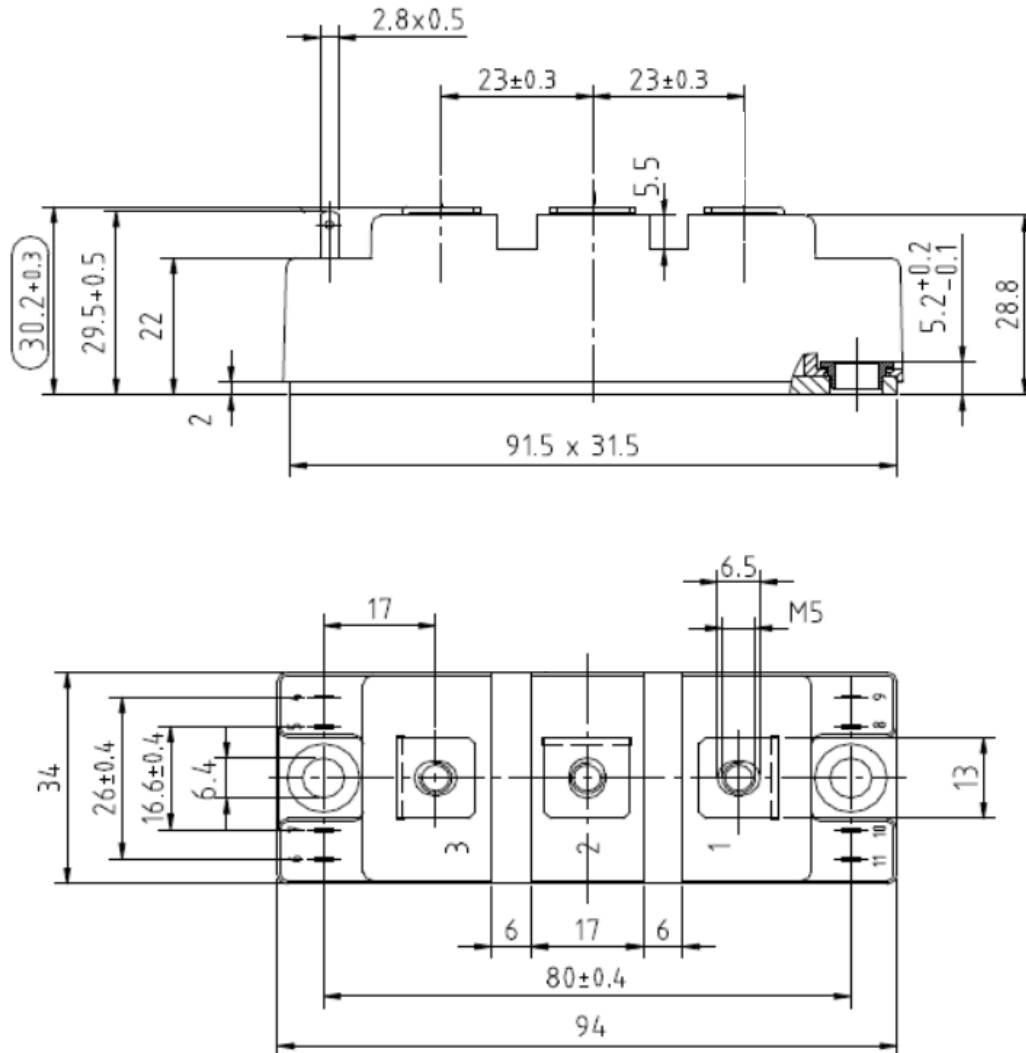

Figure 2. Pin configuration

Module

Parameter	Conditions	Value	Unit
Isolation Voltage	RMS, $f = 50\text{Hz}$, $t = 1\text{min}$	2.5	KV
Material of module baseplate	-	Cu	-
Creepage distance	terminal to heatsink	26	mm
	terminal to terminal	21	
Clearance	terminal to heatsink	23.6	mm
	terminal to terminal	10	
CTI	-	>200	-
Module lead resistance, terminals – chip	$T_c = 25^\circ\text{C}$	0.8	m Ω
Mounting torque for module mounting	M5, M6	3 to 6	Nm
Weight	-	160	g

HCG150FF120A11

1200V/150A Half Bridge IGBT Module

Maximum Ratings (IGBT, $T_j=25^\circ\text{C}$ unless otherwise specified)

Symbol	Parameter	Conditions	Ratings	Unit
V_{CES}	Collector-Emitter Voltage	G-E Short	1200	V
V_{GES}	Gate-Emitter Voltage	C-E Short	$\pm 30\text{V}$	V
I_C	DC Continuous Collector Current	$T_c=100^\circ\text{C}$	150	A
I_{CM}	Pulse Collector Current	$t_p=1\text{ms}$, Note1	300	A
P_C	Maximum Power Dissipation	$T_c=25^\circ\text{C}$, $T_j=150^\circ\text{C}$ (IGBT)	500	W
T_{jop}	junction temperature	-	-40 to 150	$^\circ\text{C}$
T_{stg}	Storage temperature	-	-40 to 125	$^\circ\text{C}$

Note1: Pulse width limited by maximum junction temperature

Maximum Ratings (Freewheeling diode, $T_j=25^\circ\text{C}$ unless otherwise specified)

Symbol	Parameter	Conditions	Ratings	Unit
V_{RRM}	Peak Repetitive Revers Voltage	-	1200	V
I_F	Diode forward Current	$T_c=100^\circ\text{C}$	150	A
I_{FRM}	Repetitive peak forward Current	$t_p=1\text{ms}$, Note1	300	A
T_{jop}	junction temperature	-	-40 to 150	$^\circ\text{C}$
T_{stg}	Storage temperature	-	-40 to 125	$^\circ\text{C}$

Note1: Pulse width limited by maximum junction temperature

IGBT Electrical characteristics ($T_j=25^\circ\text{C}$ unless otherwise specified, chip)

Symbol	Item	Condition	Value			Unit	
			Min.	Typ.	Max		
$V_{CE(sat)}$	Collector-Emitter Saturation Voltage	$I_C=150\text{A}$	$T_j=25^\circ\text{C}$	-	2.30	2.50	V
		$V_{GE}=15\text{V}$		$T_j=125^\circ\text{C}$	-	2.70	-
$V_{GE(th)}$	Gate-Emitter threshold Voltage	$I_C=1\text{mA}$, $V_{CE}=V_{GE}$		4.5	-	5.7	V
Q_G	Gate charge	$V_{GE} = -15\text{V to } +15\text{V}$		-	1140	-	nC
R_{Gint}	Internal gate resistor	$f=1\text{M}$, $V_{pp}=1\text{V}$	$T_j=25^\circ\text{C}$	-	2.5	-	Ω
C_{ies}	Input Capacitance	$V_{CE}=25\text{V}$, $V_{GE}=0\text{V}$ $f=1\text{MHz}$	$T_j=25^\circ\text{C}$	-	10.8	-	nF
C_{oes}	Output Capacitance			-	1.65	-	nF
C_{res}	Reverse transfer Capacitance			-	0.94	-	nF
I_{CES}	Collector- Emitter Cut off Current	$V_{CE}=1200\text{V}$, $V_{GE}=0\text{V}$	$T_j=25^\circ\text{C}$	-	-	1	mA
I_{GES}	Gate-Emitter Leakage Current	$V_{GE} = \pm 30\text{V}$, $V_{CE}=0\text{V}$	$T_j=25^\circ\text{C}$	-	-	200	nA
$t_{d(on)}$	Turn-on delay time	$V_{CC} = 600\text{V}$	$T_j=25^\circ\text{C}$	-	35	-	ns
			$T_j=125^\circ\text{C}$	-	40	-	
t_r	Rise time	$I_C = 150\text{A}$ $R_G = 4.7\Omega$	$T_j=25^\circ\text{C}$	-	55	-	ns
			$T_j=125^\circ\text{C}$	-	60	-	
$t_{d(off)}$	Turn-off delay time	$V_{GE} = \pm 15\text{V}$ Inductive Load	$T_j=25^\circ\text{C}$	-	340	-	ns
			$T_j=125^\circ\text{C}$	-	370	-	

HCG150FF120A11

1200V/150A Half Bridge IGBT Module

t_f	Fall time	$V_{CC} = 600V$ $I_C = 150A$	$T_j = 25^\circ C$	-	90	-	ns
			$T_j = 125^\circ C$	-	120	-	
E_{on}	Turn-on power dissipation	$R_G = 4.7\Omega$ $V_{GE} = \pm 15V$	$T_j = 25^\circ C$	-	6.30	-	mJ
			$T_j = 125^\circ C$	-	8.00	-	
E_{off}	Turn-off power dissipation	Inductive Load	$T_j = 25^\circ C$	-	4.10	-	mJ
			$T_j = 125^\circ C$	-	7.20	-	
$R_{th(j-c)}$	Thermal Resistance, Junction to Case (IGBT)			-		0.25	$^\circ C/W$

Freewheeling Diode Electrical characteristics ($T_j = 25^\circ C$ unless otherwise specified, chip)

Symbol	Item	Condition	Value			Unit	
			Min.	Typ.	Max		
V_F	Diode Forward Voltage	$I_F = 150A, V_{GE} = 0V$	$T_j = 25^\circ C$	-	1.90	2.2	V
			$T_j = 125^\circ C$	-	1.90	-	
t_{rr}	Diode Reverse Recovery Time		$T_j = 25^\circ C$		150		nS
			$T_j = 125^\circ C$		200		
I_{rr}	Peak reverse recovery Current	$I_F = 150A,$ $di/dt = 2600A/\mu s,$	$T_j = 25^\circ C$	-	165	-	A
			$T_j = 125^\circ C$	-	190	-	
Q_{rr}	Recovered charge	$V_R = 600V,$ $V_{GE} = -15V$	$T_j = 25^\circ C$	-	14.50	-	uC
			$T_j = 125^\circ C$	-	21.00	-	
E_{rr}	Reverse recovered energy		$T_j = 25^\circ C$	-	4.5	-	mJ
			$T_j = 125^\circ C$	-	7.3	-	
$R_{th(j-c)}$	Thermal Resistance, Junction to Case (Diode)		-		0.38	$^\circ C/W$	

HCG150FF120A11

1200V/150A Half Bridge IGBT Module

Test Conditions

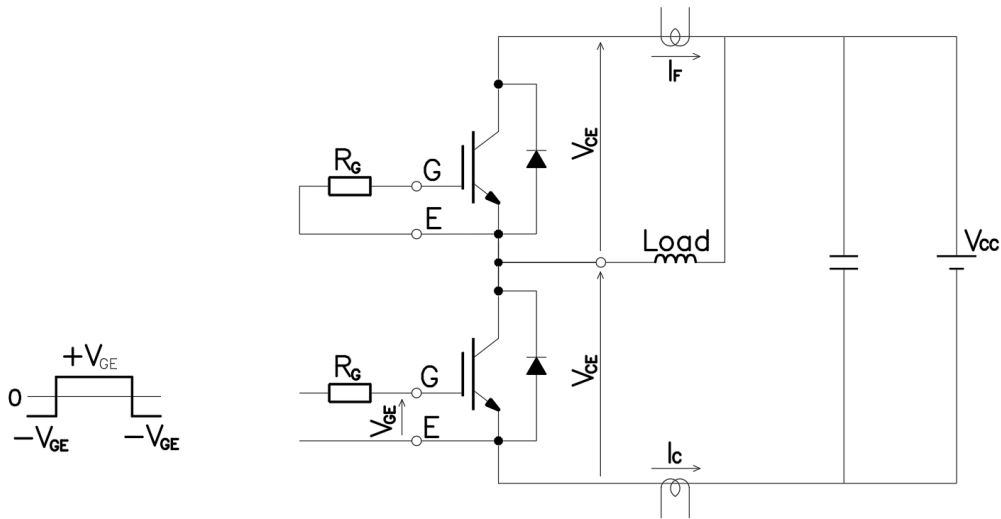

Figure 3. Switching time measure circuit

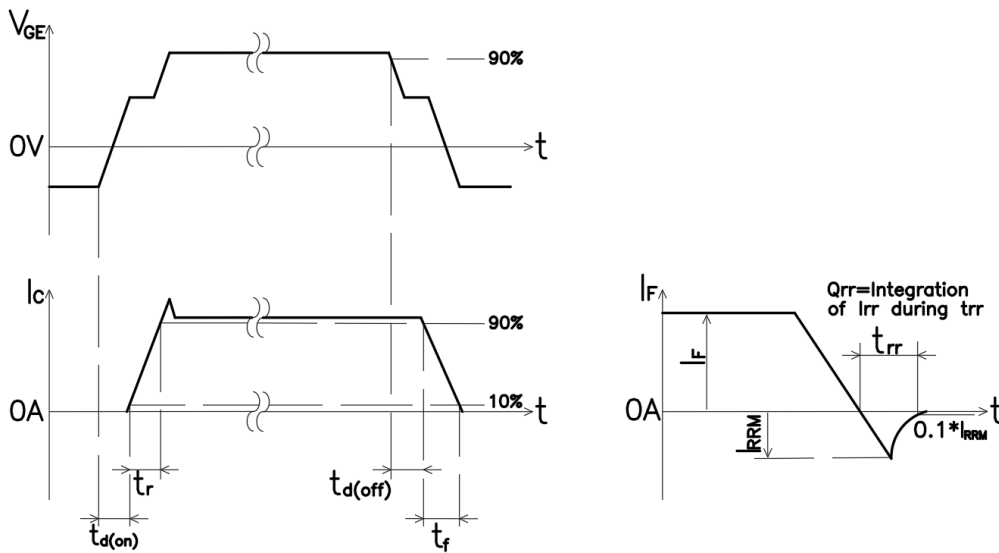

Figure 4. Switching time definition

HC1G50FF120A11

1200V/150A Half Bridge IGBT Module

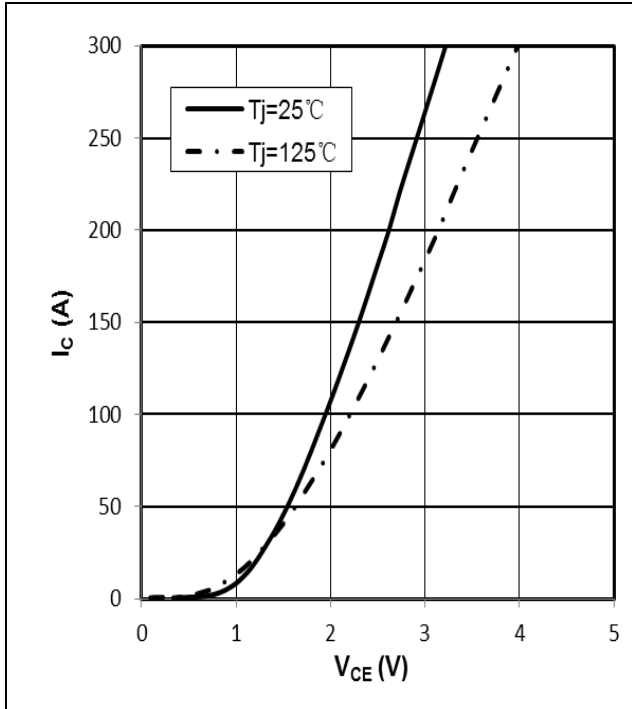

Figure 5. I_c vs V_{CE}
 $V_{GE}=15V$

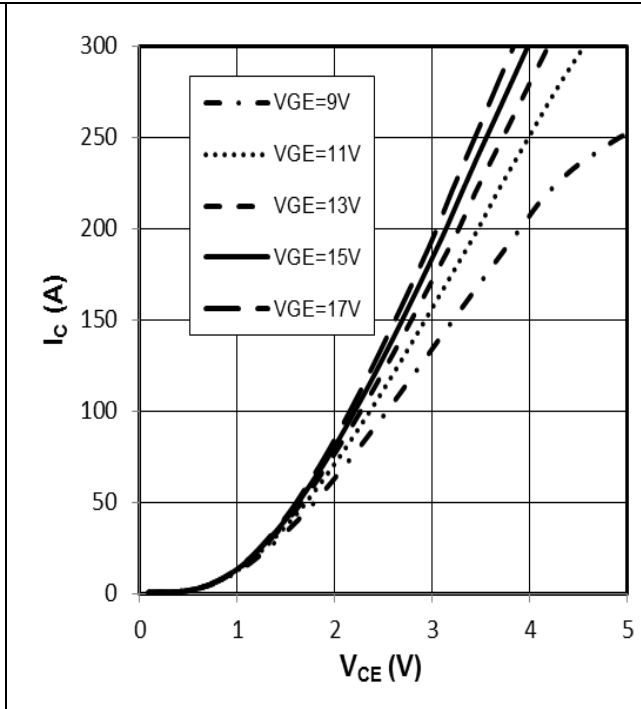

Figure 6. I_c vs V_{CE}
 $T_j=125^\circ C$

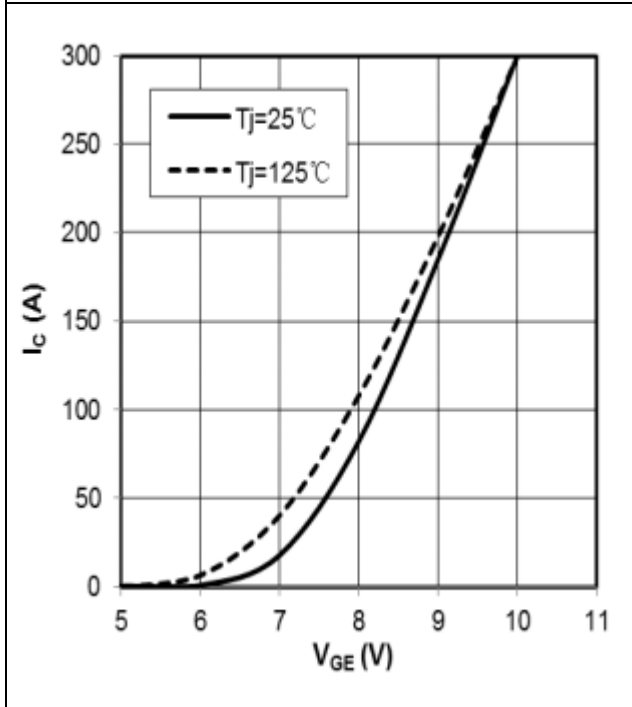

Figure 7. I_c vs V_{GE}
 $V_{CE}=20V$

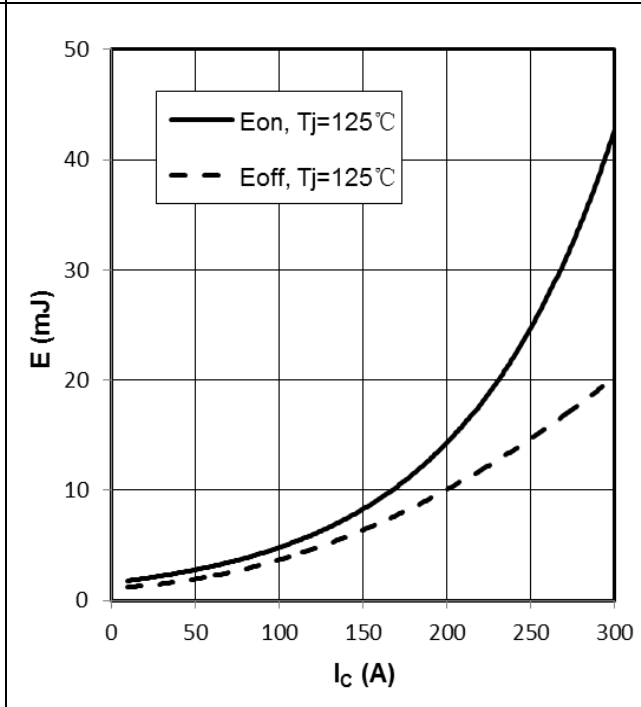

Figure 8. E_{on}, E_{off} vs I_c (Typ)
 $V_{CC}=600V, V_{GE}=+15V/-15V, R_G=4.7\Omega$

HCG150FF120A11

1200V/150A Half Bridge IGBT Module

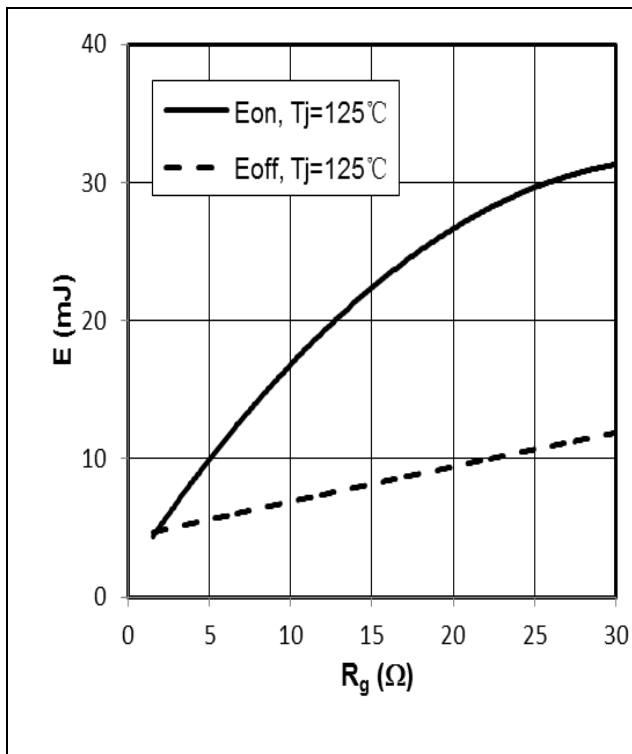

Figure 9. E_{on} , E_{off} vs R_g (Typ)
 $V_{CC}=600V$, $V_{GE}=+15V/-15V$, $I_C=150A$

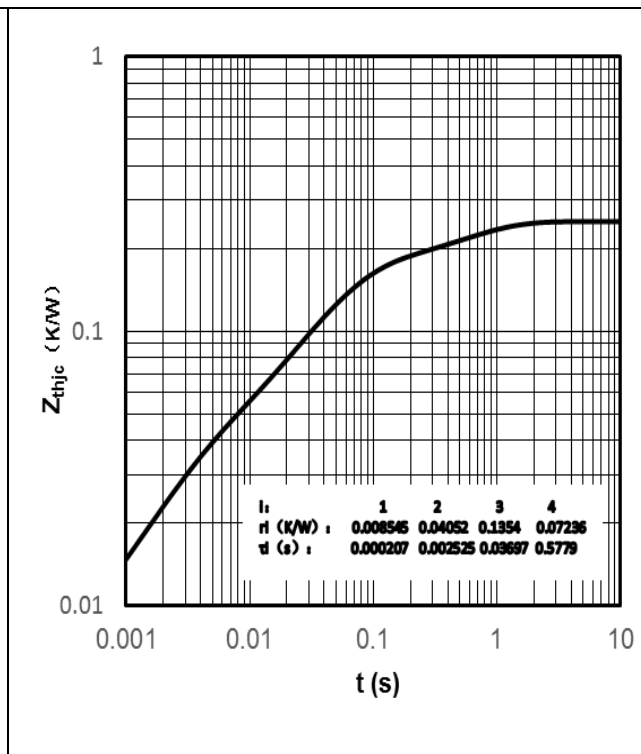

Figure 10. Transient thermal impedance IGBT ,
 $Z_{thjc}=f(t)$

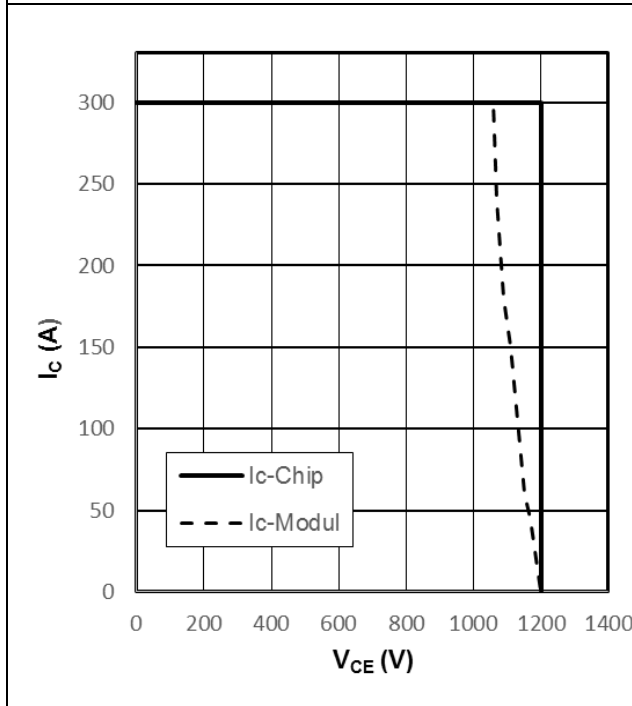

Figure 11. Reverse bias safe operating area IGBT,
 $I_C=f(V_{CE})$, $V_{GE}=\pm 15V$, $R_{Goff}=4.7\Omega$, $T_{vj}=125^\circ C$

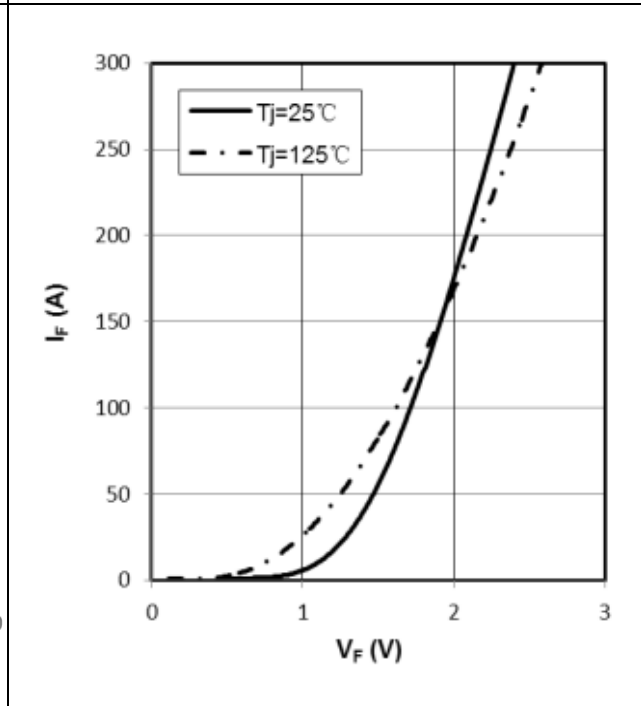

Figure 12. Forward characteristic of Diode ,
 $I_F=f(V_F)$

HCG150FF120A11

1200V/150A Half Bridge IGBT Module

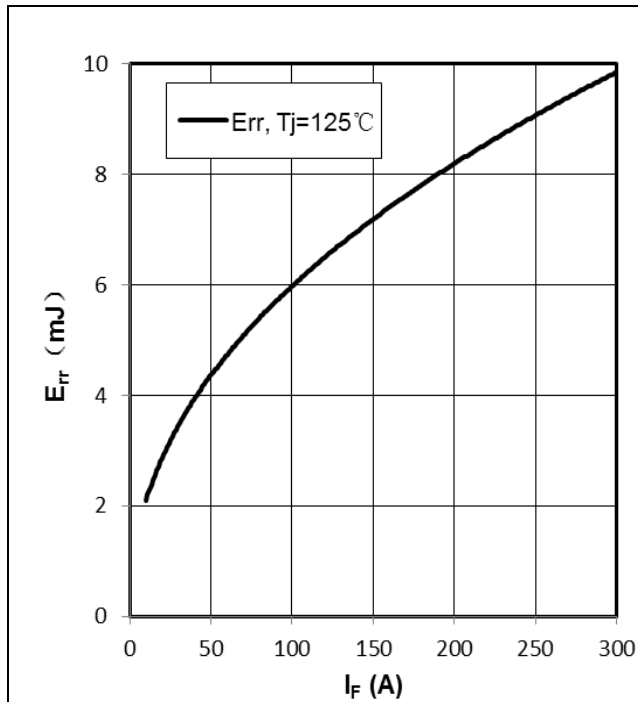

Figure 13. Switching losses Diode,
 $E_{rr}=f(I_F)$, $R_{Gon}=4.7\Omega$, $V_{CE}=600V$

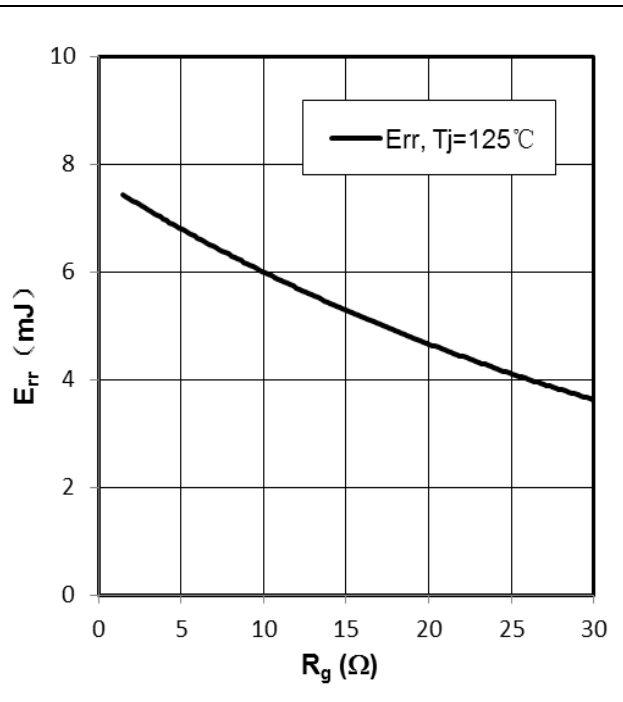

Figure 14. Switching losses Diode,
 $E_{rr}=f(R_g)$, $I_F=150A$, $V_{CE}=600V$

IMPORTANT NOTICE:

This product data sheet describes the characteristics of this product for which a warranty is granted. Any such warranty is granted exclusively under the terms and conditions of the supply agreement. There will be no guarantee or of any kind for the product and its characteristics.

The data contained in this document is exclusively intended for technically trained staff. You and your technical departments will have to evaluate the product's suitability for the intended application and the completeness of the product data concerning such application.

Due to technical requirements, our product may contain dangerous substances. For information on the types in question, please contact the sales staff responsible for you.

Changes to this product data sheet are reserved.

Please contact the sales staff (Email:sales@hiitio.com) for further information on the product, technology, delivery terms, conditions and prices.

Instruction note

Naming rules for power module product models (Industrial module)

Product Model																																							
	HC	G	100	FF	120	E3	A																																
Hecheng Code																																							
Module type G : IGBT module D : FRD module S : SiC module H : Si/SiC hybrid																																							
Current level (A) 50~900																																							
Topology structure FZ : A switch unit FF : Half bridge FS : Three phase F4 : H Bridge F3L : Three level DF : Boost Circuit FD : Braking Circuit FP : Rectification+Inverter+Control move AL : ANPC CL : Chopper																																							
Voltage level (x10) (V) 650~2200																																							
Packaging form+features (A...Z) <table border="0"> <tr> <td>A1: 34 mm</td> <td>A2: 62 mm</td> <td></td> <td></td> </tr> <tr> <td>B1: Easy 1B</td> <td>B1A</td> <td>B1B...</td> <td></td> </tr> <tr> <td>B2: Easy 2B...</td> <td>B3: Easy 3B...</td> <td></td> <td></td> </tr> <tr> <td>D1: Flow0</td> <td>D2: Flow1</td> <td>D3: Flow2</td> <td></td> </tr> <tr> <td>E0: E0</td> <td>E1: Econo 2...</td> <td>E2: E2</td> <td></td> </tr> <tr> <td>E3: ED3</td> <td>E4: E4</td> <td>E5: ED3S</td> <td></td> </tr> <tr> <td>E6: EPM2</td> <td>E7: EPM3</td> <td>E8: EconoPIM3</td> <td></td> </tr> <tr> <td>E9: ED3H</td> <td>F0: F0</td> <td>P2: EPM2</td> <td></td> </tr> </table>								A1: 34 mm	A2: 62 mm			B1: Easy 1B	B1A	B1B...		B2: Easy 2B...	B3: Easy 3B...			D1: Flow0	D2: Flow1	D3: Flow2		E0: E0	E1: Econo 2...	E2: E2		E3: ED3	E4: E4	E5: ED3S		E6: EPM2	E7: EPM3	E8: EconoPIM3		E9: ED3H	F0: F0	P2: EPM2	
A1: 34 mm	A2: 62 mm																																						
B1: Easy 1B	B1A	B1B...																																					
B2: Easy 2B...	B3: Easy 3B...																																						
D1: Flow0	D2: Flow1	D3: Flow2																																					
E0: E0	E1: Econo 2...	E2: E2																																					
E3: ED3	E4: E4	E5: ED3S																																					
E6: EPM2	E7: EPM3	E8: EconoPIM3																																					
E9: ED3H	F0: F0	P2: EPM2																																					
Feature :A: Special Code Nil: Standard																																							

Zhejiang HIITIO New Energy Co., Ltd

ADD : NO.1125 Zhixing Road,Qiaonan District, Xiaoshan Economic and Technological Development Zone, Hangzhou, Zhejiang

TEL :400-667-9977

