

HCG200FF170A2RE1

1700V/200A Half Bridge IGBT Module

Description

The HCG200FF170A2RE1 is a Half Bridge IGBT Power Module. It integrates high performance IGBT chips and offers lower losses and higher energy for the applications such as motor drive, inverter and welding machines.



Features

- 1700V 200A
- $V_{CE(sat)}(typ.)=1.65V@25^{\circ}C$
- Lower losses and higher energy
- High speed switching

Applications

- Motor drive
- Inverter
- Welding machines
- Power supply
- UPS

Circuit diagram

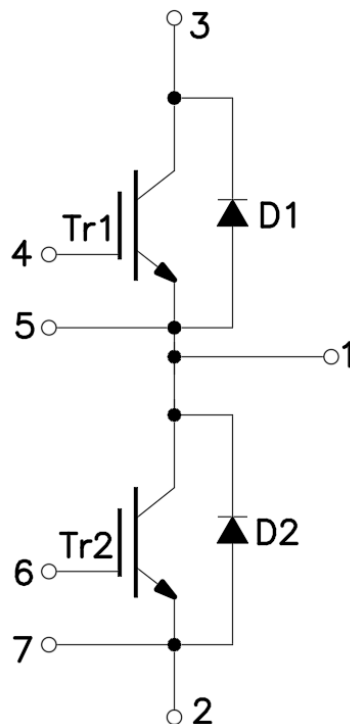

Figure 1. Out drawing & circuit diagram for HCG200FF170A2RE1

HCG200FF170A2RE1

1700V/200A Half Bridge IGBT Module

Pin Configuration and Marking Information

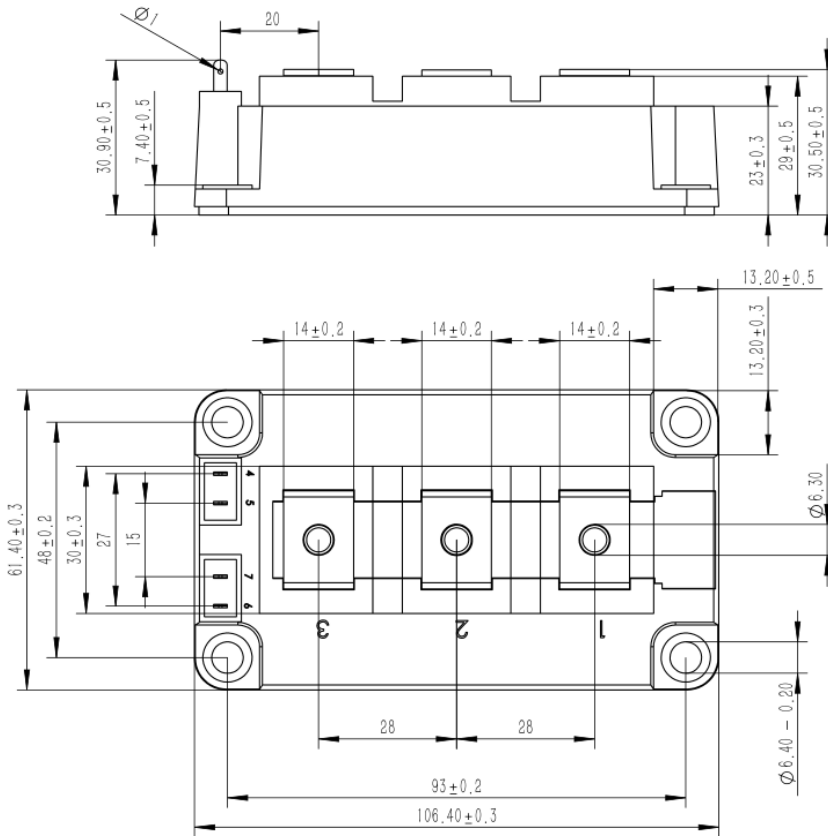

Figure 2. Pin configuration

HCG200FF170A2RE1

1700V/200A Half Bridge IGBT Module

Module

Parameter	Condition	Value	Unit
Isolation Voltage	RMS, f=50Hz, t=1min	4.0	kV
Material of module baseplate	-	Cu	-
Creepage distance	terminal to heatsink	47	mm
	terminal to terminal	26	
Clearance	terminal to heatsink	29	mm
	terminal to terminal	14	
CTI	-	>200	-
Module lead resistance, terminals – chip	T _C =25°C	0.8	mΩ
Mounting torque for module mounting	M6	3 to 6	Nm
Weight	-	315	g

Maximum Ratings (T_j=25°C unless otherwise specified)

Symbol	Parameter	Conditions	Ratings	Unit
V _{CES}	Collector-Emitter Voltage	G-E Short	1700	V
V _{GES}	Gate-Emitter Voltage	C-E Short	±20	V
I _C	DC Continuous Collector Current	T _C =125°C	200	A
I _{CM}	Pulse Collector Current	t _p =1ms, Note1	400	A
P _C	Maximum Power Dissipation	T _C =25°C, IGBT	1364	W
I _F	Diode Forward Current	-	200	A
I _{FRM}	Repetitive peak forward Current	t _p =1ms, Note1	400	A
T _j	junction temperature	-	-40 to 175	°C
T _{stg}	Storage temperature	-	-40 to 125	°C

Note1: Pulse width limited by maximum junction temperature

NTC characteristics

Symbol	Parameter	Condition	Value			Unit
			Min.	Typ.	Max.	
R ₂₅	Resistance	T _C =25°C	-	5	-	kΩ
Δ/R	Deviation of R ₁₀₀	T _C =100°C, R ₁₀₀ =493Ω	-5	-	5	%
P ₂₅	Power dissipation	T _C =25°C	-	-	20	mW
B _{25/50}	B-value	R ₂ = R ₂₅ exp [B _{25/50} (1/T ₂ - 1/(298,15 K))]	-	3375	-	K
B _{25/80}	B-value	R ₂ = R ₂₅ exp [B _{25/80} (1/T ₂ - 1/(298,15 K))]	-	3411	-	K
B _{25/100}	B-value	R ₂ = R ₂₅ exp [B _{25/100} (1/T ₂ - 1/(298,15 K))]	-	3433	-	K

HCG200FF170A2RE1

1700V/200A Half Bridge IGBT Module

IGBT Electrical characteristics (T_j=25°C unless otherwise specified, chip)

Symbol	Item	Condition	Value			Unit	
			Min.	Typ.	Max.		
V _{CE(sat)}	Collector-Emitter Saturation Voltage	I _C =200A V _{GE} =15V	T _j =25°C	-	1.65	1.90	V
			T _j =125°C	-	1.75	-	V
			T _j =150°C	-	1.85	-	V
			T _j =175°C	-	1.90	-	V
V _{GE(th)}	Gate-Emitter threshold Voltage	I _C =8mA, V _{CE} =V _{GE}	5.0	-	6.5	V	
Q _G	Gate charge	V _{GE} =-15V to +15V, V _{CC} =900V	-	2.1	-	uC	
R _{Gint}	Internal gate resistor	-	T _j =25°C	-	-	Ω	
C _{ies}	Input Capacitance	V _{CE} =25V,	T _j =25°C	-	16.5	-	nF
C _{oes}	Output Capacitance	V _{GE} =0V		-	0.67	-	nF
C _{res}	Reverse transfer Capacitance	f=1MHz		-	0.25	-	nF
I _{CES}	Collector- Emitter Cut off Current	V _{CE} =1700V, V _{GE} =0V	T _j =25°C	-	-	1	mA
I _{GES}	Gate-Emitter Leakage Current	V _{GE} =20V, V _{CE} =0V	T _j =25°C	-	-	1	uA
t _{d(on)}	Turn-on delay time	V _{CC} =900V I _C =200A V _{GE} =+15V/-8V R _{Gon} = R _{Goff} =3.0Ω Inductive load	T _j =25°C	-	204	-	ns
			T _j =150°C	-	208	-	ns
t _r	Rise time		T _j =25°C	-	126	-	ns
			T _j =150°C	-	191	-	ns
t _{d(off)}	Turn-off delay time		T _j =25°C	-	568	-	ns
			T _j =150°C	-	731	-	ns
t _f	Fall time		T _j =25°C	-	370	-	ns
			T _j =150°C	-	679	-	ns
E _{on}	Turn-on power dissipation		T _j =25°C	-	78.3	-	mJ
			T _j =150°C	-	127.5	-	mJ
E _{off}	Turn-off power dissipation	T _j =25°C	-	44.8	-	mJ	
		T _j =150°C	-	68.1	-	mJ	
R _{th(j-c)}	Thermal Resistance, Junction to Case (IGBT)		-	0.11	-	°C /W	
R _{th(c-s)}	Thermal Resistance, Case to sink (Conductive Grease applied) , Note1		-	0.030	-	°C /W	

Note1: Assumes Thermal Conductivity of grease is 2.8 W/m · K and thickness is 50um.

HCG200FF170A2RE1

1700V/200A Half Bridge IGBT Module

Freewheeling Diode Electrical characteristics (T_j=25°C unless otherwise specified, chip)

Symbol	Item	Condition	Value			Unit	
			Min.	Typ.	Max.		
V _F	Diode Forward Voltage	I _F = 200A, V _{GE} = 0V	T _j = 25°C	-	1.80	2.1	V
			T _j = 125°C	-	1.75	-	V
			T _j = 150°C	-	1.75	-	V
			T _j = 175°C	-	1.72	-	V
t _{rr}	Reverse recovery time	(Switch side) V _{CC} = 900V, I _C = 200A	T _j = 25°C	-	1073	-	ns
			T _j = 150°C	-	1504	-	ns
I _{RM}	Peak reverse recovery Current	V _{GE} = +15V/-8V, R _G = 3.0Ω (FRD side)	T _j = 25°C	-	91	-	A
			T _j = 150°C	-	110	-	A
Q _{rr}	Recovered charge	V _{rr} = 900V, I _F = 200A V _{GE} = -8V	T _j = 25°C	-	38	-	uC
			T _j = 150°C	-	81	-	uC
E _{rr}	Reverse recovered energy	Inductive load switching operation	T _j = 25°C	-	17.5	-	mJ
			T _j = 150°C	-	41.7	-	mJ
R _{th(j-c)}	Thermal Resistance, Junction to Case (Diode)		-	0.18	-	°C/W	
R _{th(c-s)}	Thermal Resistance, Case to sink (Conductive Grease applied), Note1		-	0.040	-	°C/W	

Note1: Assumes Thermal Conductivity of grease is 2.8 W/m · K and thickness is 50um.

Test Conditions

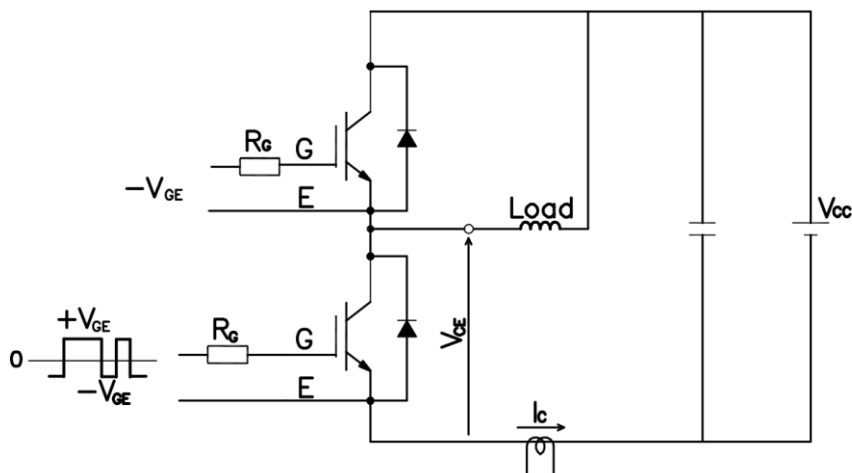

Figure 3. Switching time measure circuit

HCG200FF170A2RE1

1700V/200A Half Bridge IGBT Module

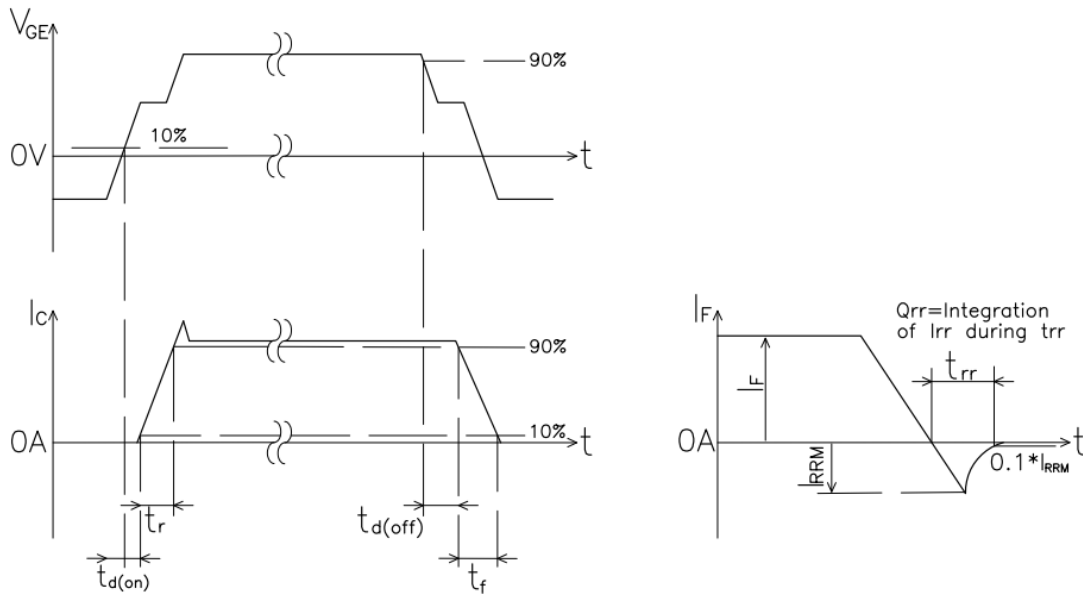

Figure 4. Switching time definition

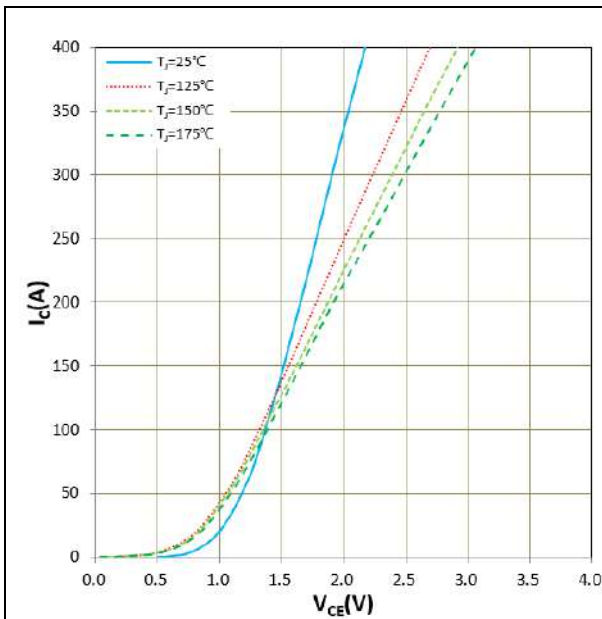

Figure 5. I_c vs V_{CE}
 $V_{GE} = 15V$

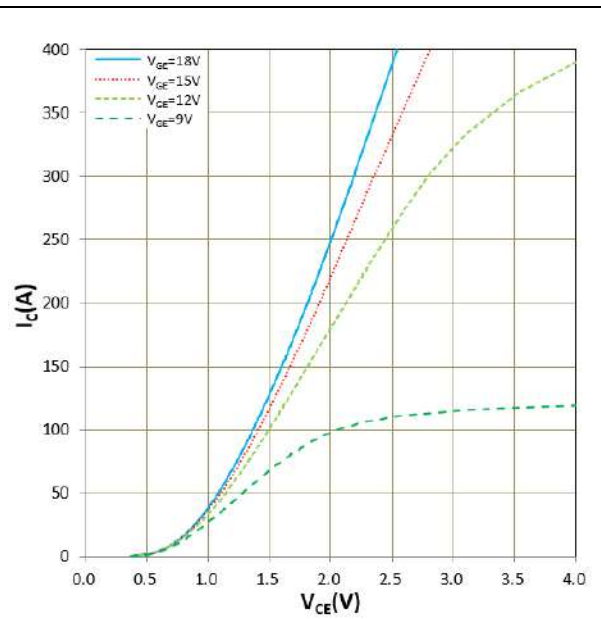

Figure 6. I_c vs V_{CE}
 $T_j = 175^\circ C$

HCG200FF170A2RE1
1700V/200A Half Bridge IGBT Module

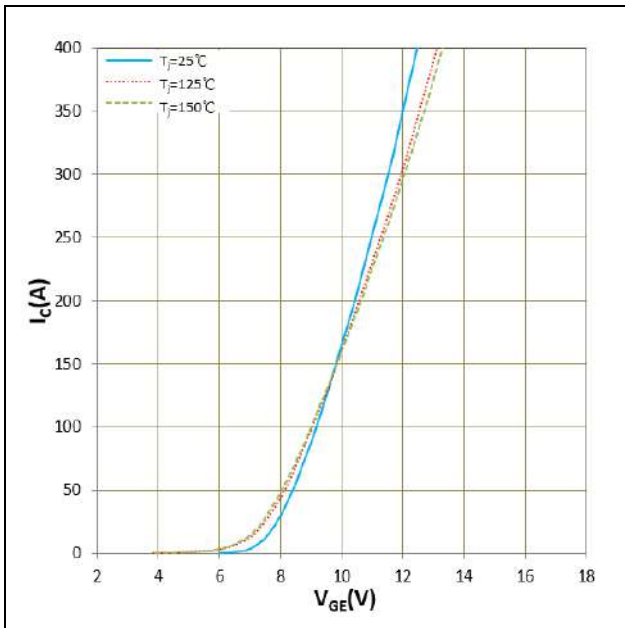

Figure 7. I_c vs V_{GE}
 $V_{CE}=20\text{V}$

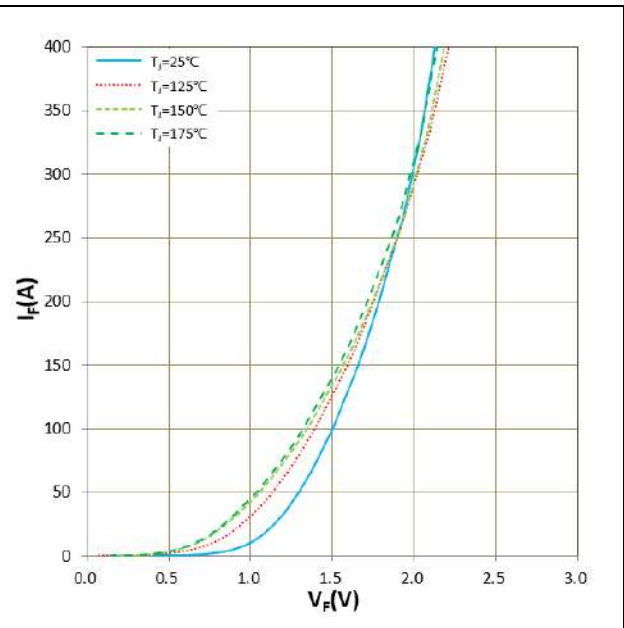

Figure 8. I_F vs V_F

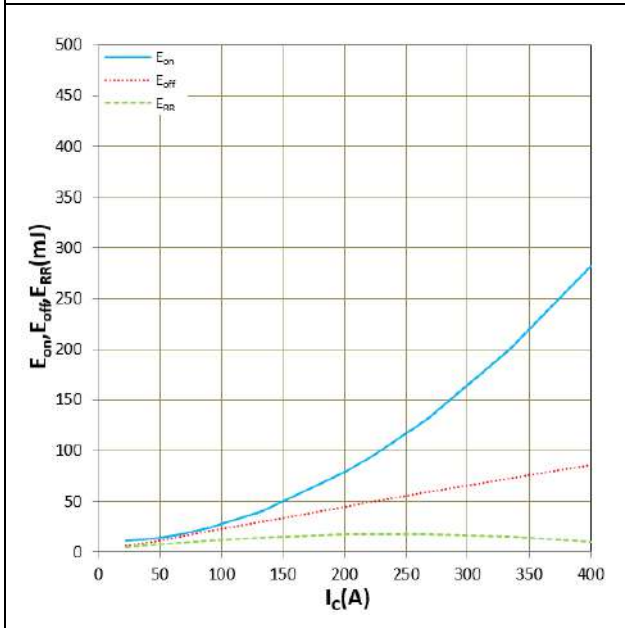

Figure 9. E_{on}, E_{off}, E_{Tr} vs I_c (Typ)
 $V_{CC}=900\text{V}, V_{GE}=+15\text{V}/-8\text{V}, R_g=3.0\Omega, T_j=25^\circ\text{C}$
Inductive Load

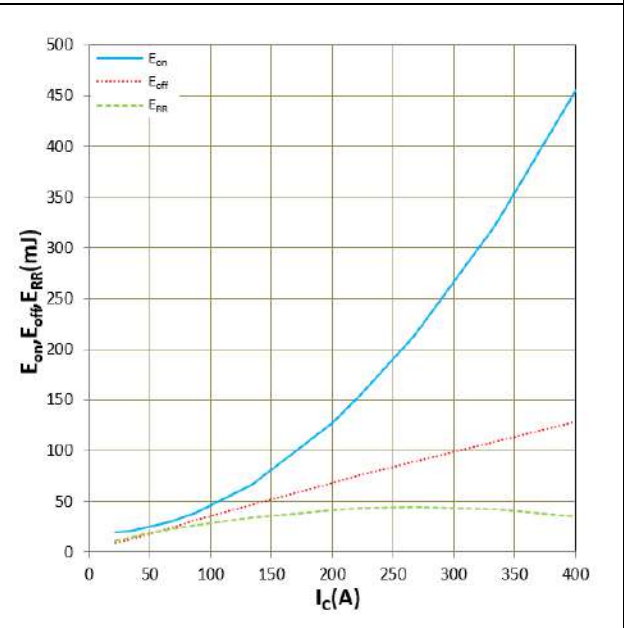

Figure 10. E_{on}, E_{off}, E_{Tr} vs I_c (Typ)
 $V_{CC}=900\text{V}, V_{GE}=+15\text{V}/-8\text{V}, R_g=3.0\Omega, T_j=150^\circ\text{C}$
Inductive Load

HCG200FF170A2RE1

1700V/200A Half Bridge IGBT Module

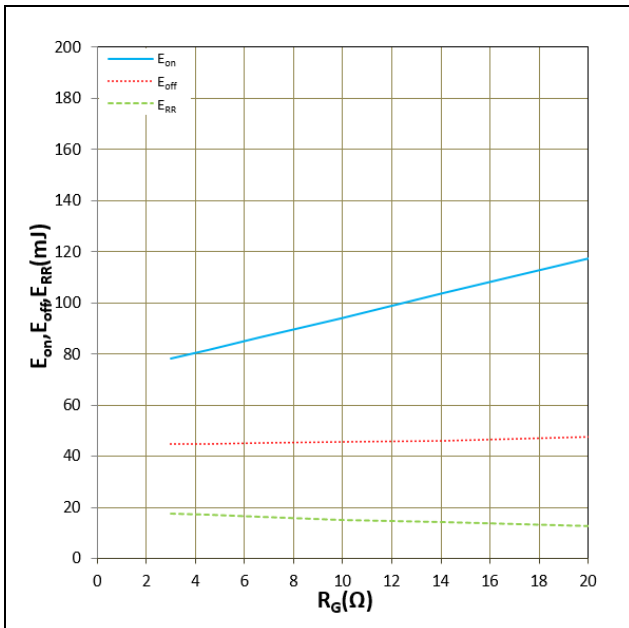

Figure 11. E_{on} , E_{off} , E_{rr} vs R_g (Typ)
 $V_{CC}=900V$, $V_{GE}=+15V/-8V$, $I_C=200A$, $T_j=25^\circ C$
 Inductive Load

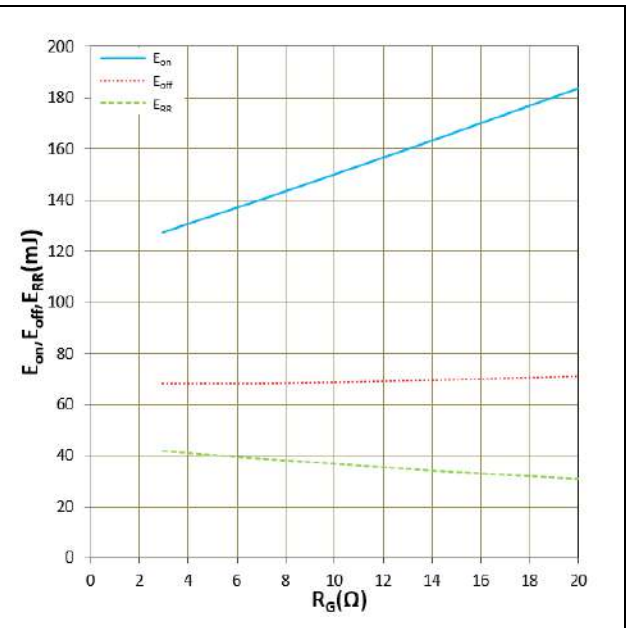

Figure 12. E_{on} , E_{off} , E_{rr} vs R_g (Typ)
 $V_{CC}=900V$, $V_{GE}=+15V/-8V$, $I_C=200A$, $T_j=150^\circ C$
 Inductive Load

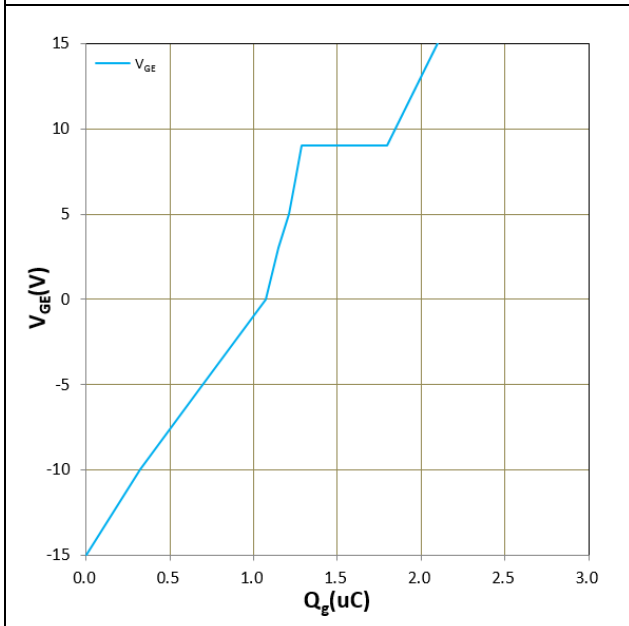

Figure 13. Gate charge

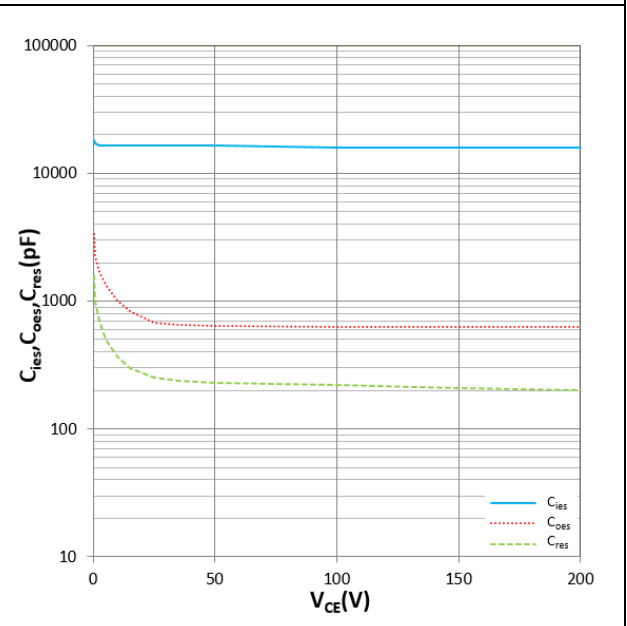

Figure 14. C_{ies} , C_{oes} , C_{res} vs V_{CE}
 $T_j=25^\circ C$, $f=1MHz$

HCG200FF170A2RE1

1700V/200A Half Bridge IGBT Module

IMPORTANT NOTICE:

This product data sheet describes the characteristics of this product for which a warranty is granted. Any such warranty is granted exclusively under the terms and conditions of the supply agreement. There will be no guarantee or of any kind for the product and its characteristics.

The data contained in this document is exclusively intended for technically trained staff. You and your technical departments will have to evaluate the product's suitability for the intended application and the completeness of the product data concerning such application.

Due to technical requirements, our product may contain dangerous substances. For information on the types in question, please contact the sales staff responsible for you.

Changes to this product data sheet are reserved.

Please contact the sales staff (Email:sales@hiitio.com) for further information on the product, technology, delivery terms, conditions and prices.

Instruction note

Naming rules for power module product models (Industrial module)

Product Model							
	HC	G	100	FF	120	E3	A
Hecheng Code							
Module type G : IGBT module D : FRD module S : SiC module H : Si/SiC hybrid							
Current level (A) 50~900							
Topology structure FZ : A switch unit FF : Half bridge FS : Three phase F4 : H Bridge F3L : Three level DF : Boost Circuit FD : Braking Circuit FP : Rectification+Inverter+Control move AL : ANPC CL : Chopper							
Voltage level (x10) (V) 650~2200							
Packaging form+features (A...Z) A1 : 34 mm A2 : 62 mm B1 : Easy 1B B1A B2 : Easy 2B... B3 : Easy 3B... B1B... D1 : Flow0 D2 : Flow1 D3 : Flow2 E0 : E0 E1 : Econo 2... E2 : E2 E3 : ED3 E4 : E4 E5 : ED3S E6 : EPM2 E7 : EPM3 E8 : EconoPIM3 E9 : ED3H F0 : F0 P2 : EPM2							
Feature :A: Special Code Nil: Standard							

Zhejiang HIITIO New Energy Co., Ltd

ADD : NO.1125 Zhixing Road,Qiaonan District, Xiaoshan Economic and Technological Development Zone, Hangzhou, Zhejiang

TEL :400-667-9977

