

HCS02FS120HDB2S

1200V/600A 3 Phase SiC MOSFET Module

Description

The HCS02FS120HDB2S is a 3 Phase SiC MOSFET Power Module. It integrates high performance SiC MOSFET chips for xEV or motor drives application.



Features

- Blocking Voltage 1200V
- $R_{DS(on)}=2.1m\Omega$ ($V_{GS}=18V, T_j=25^\circ C$)
- 175°C Maximum Junction Temperature
- Si₃N₄ AMB Substrate
- Direct Cooled Pin Fin Base Plate
- Thermistor Inside
- Press FIT Contact Technology

Application

- xEV Applications
- Motor Drives

Circuit Diagram

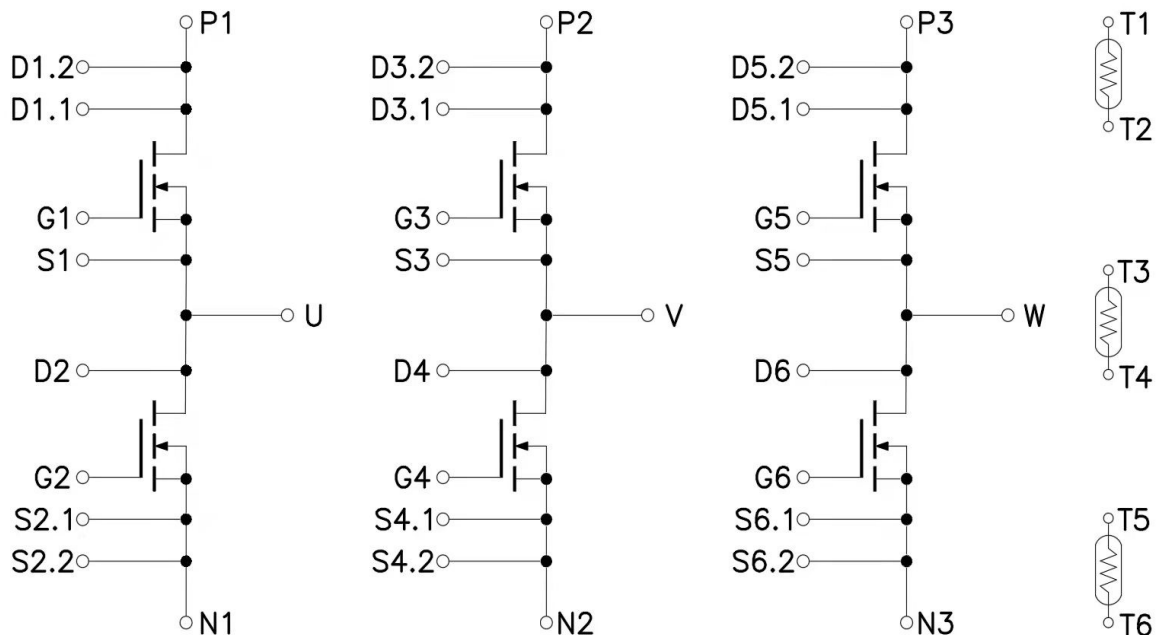

Figure 1. Out Drawing & Circuit Diagram HCS02FS120HDB2S

HCS02FS120HDB2S

1200V/600A 3 Phase SiC MOSFET Module

Physical Dimensions

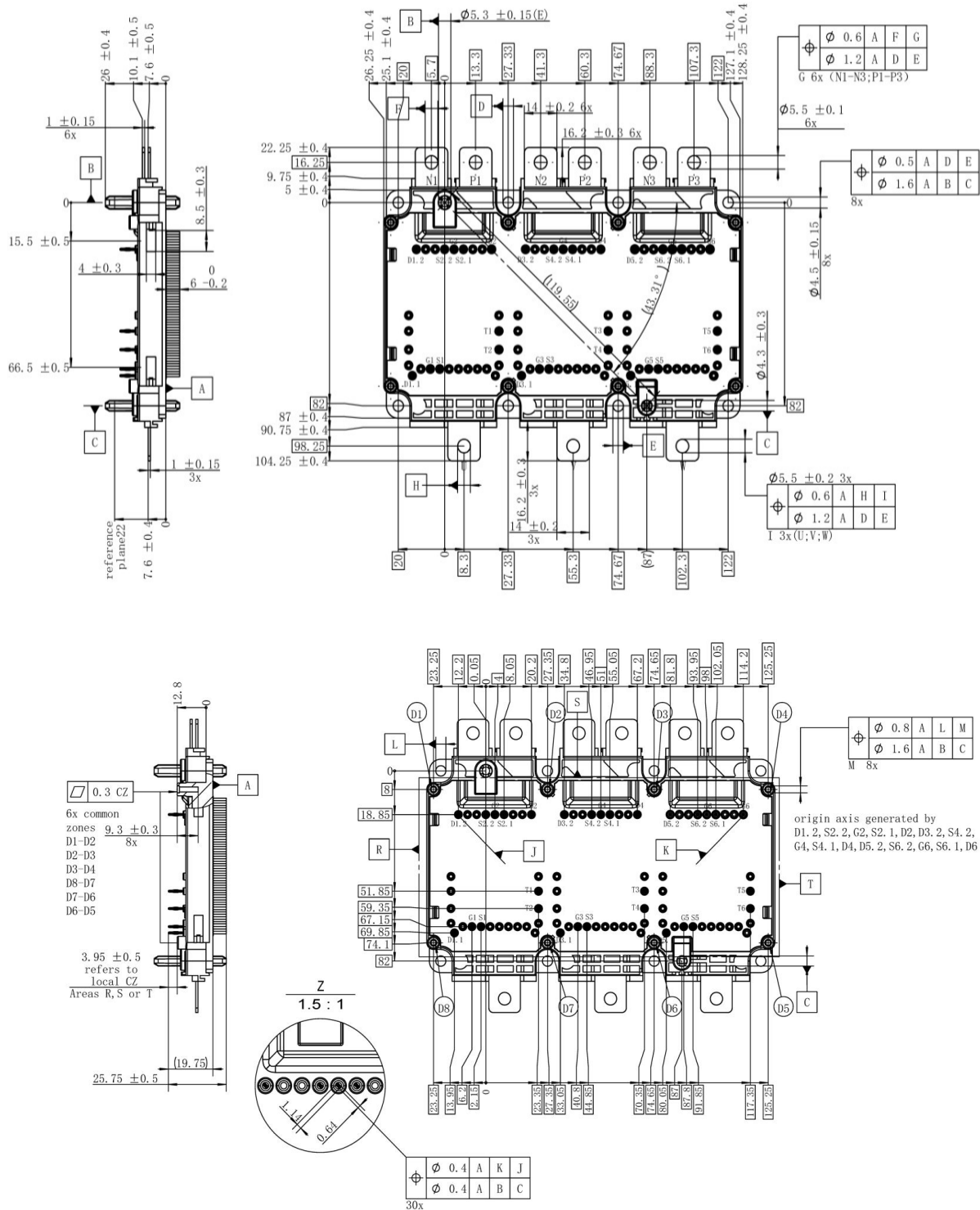

Figure 2. Physical Dimensions

HCS02FS120HDB2S

1200V/600A 3 Phase SiC MOSFET Module

Maximum Ratings ($T_j=25^{\circ}\text{C}$ Unless Otherwise Specified)

Symbol	Parameter	Conditions	Value	Unit
V_{DSS}	Drain-Source Voltage	G-S Short	1200	V
V_{GSS}	Gate-Source Voltage	D-S Short, AC frequency • 4Hz, Note1	-11V/+23V	V
I_{DS}	DC Continuous Drain Current	$T_f=25^{\circ}\text{C}$, $V_{\text{GS}}=18\text{V}$	590	A
I_{DS}	DC Continuous Drain Current	$T_f=65^{\circ}\text{C}$, $V_{\text{GS}}=18\text{V}$	505	A
I_{SD}	Source (Body Diode) Current	$T_f=25^{\circ}\text{C}$, with ON signal	590	A
I_{SD}	Source (Body Diode) Current	$T_f=65^{\circ}\text{C}$, with ON signal	505	A
I_{DP}	Drain Pulse Current, Peak	Less than 1ms, Note2	1200	A
P_{D}	Maximum Power Dissipation	$T_f=25^{\circ}\text{C}$	1613	W
T_j	Junction temperature	-	-40 to 175	$^{\circ}\text{C}$
T_{stg}	Storage temperature	-	-40 to 125	$^{\circ}\text{C}$

Note1: Recommended Operating Value: +18V/-5V, +18V/-4V, +15V/-5V, +15V/-4V

Note2: Pulse width limited by maximum junction temperature

Typical Current Output Ability

Condition: SPWM control, $V_{\text{cc}}=800\text{V}$, $V_{\text{GS}}=+18\text{V}/-4\text{V}$, $R_{\text{g(ON)}}=R_{\text{g(OFF)}}=5.1\Omega$, $T_f=65^{\circ}\text{C}$, $T_{\text{jmax}}=175^{\circ}\text{C}$, PF=0.8, Modulation rate=1

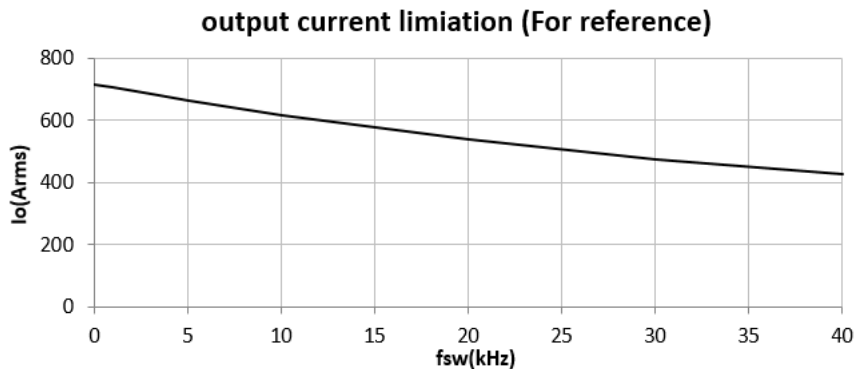

Note1: This graph is calculated value for reference based on the limitation of $T_{\text{jmax}}=175^{\circ}\text{C}$. The actual current out ability depends on inverter electrical, thermal and mechanic design. Please confirm it in actual application system.

HCS02FS120HDB2S

1200V/600A 3 Phase SiC MOSFET Module

Module

Parameter	Conditions	Value	Unit
Isolation voltage	Main terminal to base plate, f =0Hz, t =1sec	4.2	kV
Material of module baseplate	-	Cu + Ni	-
Creepage distance	terminal to heatsink terminal to terminal	9	mm
Clearance	terminal to heatsink terminal to terminal	4.5	mm
Stray inductance module	$T_f = 65^\circ\text{C}$	8	nH
Module lead resistance, terminals – chip	$T_f = 65^\circ\text{C}$	0.5	m Ω
Mounting torque for module mounting	Screw M4 baseplate to heatsink	1.8 to 2.2	Nm
Weight	-	780	g

NTC Characteristics

Symbol	Parameter	Conditions	Value			Unit
			Min.	Typ.	Max.	
R25	Resistance	$T_c = 25^\circ\text{C}$	-	5	-	k Ω
$\Delta R/R$	Deviation of R_{100}	$T_c = 100^\circ\text{C}$, $R_{100} = 493\Omega$	-5	-	5	%
P_{25}	Power dissipation	$T_c = 25^\circ\text{C}$	-	-	20	mW
$B_{25/50}$	B-value	$R_2 = R_{25} \exp [B_{25/50} (1/T_2 - 1/(298,15 \text{ K}))]$	-	3375	-	K
$B_{25/80}$	B-value	$R_2 = R_{25} \exp [B_{25/80} (1/T_2 - 1/(298,15 \text{ K}))]$	-	3411	-	K
$B_{25/100}$	B-value	$R_2 = R_{25} \exp [B_{25/100} (1/T_2 - 1/(298,15 \text{ K}))]$	-	3433	-	K

HCS02FS120HDB2S

1200V/600A 3 Phase SiC MOSFET Module

MOSFET Electrical Characteristics ($T_j=25^\circ\text{C}$ Unless Otherwise Specified, Chip)

Symbol	Parameter	Conditions	Value			Unit	
			Min.	Typ.	Max.		
$V_{(BR)DSS}$	Drain-Source Breakdown Voltage	$V_{GS}=0V, I_D=6mA$	1200	-	-	V	
I_{DSS}	Zero gate voltage drain current	$V_{DS}=1200V, V_{GS}=0V$	-	-	600	μA	
$V_{GS(Th)}$	Gate-source threshold voltage	$I_D=60mA$ $V_{DS}=V_{GS}$	$T_j=25^\circ\text{C}$	2.35	3.15	5.95	V
			$T_j=175^\circ\text{C}$	1.85	2.45	4.75	V
I_{GSS}	Gate-Source Leakage Current	$V_{GS}=20V, V_{DS}=0V$	-	-	600	nA	
$R_{DS(on)}$ (Chip)	Static drain-source On-state resistance	$I_D=600A$ $V_{GS}=18V$	$T_j=25^\circ\text{C}$	-	2.1	-	m Ω
			$T_j=175^\circ\text{C}$	-	4.6	-	m Ω
$V_{DS(on)}$ (Chip)	Static drain-source On-state resistance	$I_D=600A$ $V_{GS}=18V$	$T_j=25^\circ\text{C}$	-	1.26	-	V
			$T_j=175^\circ\text{C}$	-	2.76	-	V
C_{iss}	Input capacitance	$V_{DS}=920V$ $V_{GS}=0V$ $f=100kHz$	-	22.7	-	nF	
C_{oss}	Output capacitance		-	1.18	-	nF	
C_{riss}	Reverse transfer capacitance		-	0.07	-	nF	
Q_g	Total gate charge	$V_{DS}=920V$ $I_D=375A$ $V_{GS}=+18/-5V$	-	1062	-	nC	
Q_{gs}	Gate to source charge		-	300	-	nC	
Q_{gd}	Gate to drain charge		-	240	-	nC	
R_{gint}	Internal gate resistance	$f=1MHz$	-	1.73	-	Ω	
$t_{d(on)}$	Turn-on delay time	$V_{DD}=600V$ $I_D=600A$ $V_{GS}=+18/-5V$ $R_{G(ON)}=5.1\Omega$ $R_{G(OFF)}=5.1\Omega$ Inductive load Switching operation	$T_j=25^\circ\text{C}$	-	94	-	ns
			$T_j=150^\circ\text{C}$	-	84	-	
t_r	Rise time		$T_j=25^\circ\text{C}$	-	74	-	ns
			$T_j=150^\circ\text{C}$	-	66	-	
$t_{d(off)}$	Turn-off delay time		$T_j=25^\circ\text{C}$	-	216	-	ns
			$T_j=150^\circ\text{C}$	-	243	-	
t_f	Fall time		$T_j=25^\circ\text{C}$	-	45	-	ns
			$T_j=150^\circ\text{C}$	-	46	-	
E_{on}	Turn-on power dissipation		$T_j=25^\circ\text{C}$	-	17.92	-	mJ
			$T_j=150^\circ\text{C}$	-	18.89	-	
E_{off}	Turn-off power dissipation	$T_j=25^\circ\text{C}$	-	24.5	-	mJ	
		$T_j=150^\circ\text{C}$	-	23.63	-		
$R_{th(j-f)}$	FET Thermal Resistance	Junction to cooling fluid $\Delta V/\Delta t=10dm^3/min, T_f=65^\circ\text{C}$	-	0.093	-	K/W	

HCS02FS120HDB2S

1200V/600A 3 Phase SiC MOSFET Module

Body Diode Electrical Characteristics ($T_j=25^\circ\text{C}$ Unless Otherwise Specified, Chip)

Symbol	Parameter	Conditions	Value			Unit	
			Min.	Typ.	Max.		
V_{SD}	Body Diode Forward Voltage	$V_{GS}=-5\text{V}$ $I_{SD}=600\text{A}$	$T_j=25^\circ\text{C}$	-	5.2	-	V
			$T_j=175^\circ\text{C}$	-	4.4	-	
T_{rr}	Reverse Recovery Time	$V_{DD}=600\text{V}$ $I_D=600\text{A}$ $V_{GS}=+18/-5\text{V}$ $R_{G(ON)}=R_{G(OFF)}=5.1\Omega$ Inductive loads Switching operation	$T_j=25^\circ\text{C}$	-	23	-	ns
			$T_j=150^\circ\text{C}$	-	52	-	
Q_{rr}	Reverse Recovery Charge	$V_{DD}=600\text{V}$ $I_D=600\text{A}$ $V_{GS}=+18/-5\text{V}$ $R_{G(ON)}=R_{G(OFF)}=5.1\Omega$ Inductive loads Switching operation	$T_j=25^\circ\text{C}$	-	1.36	-	μC
			$T_j=150^\circ\text{C}$	-	8.28	-	
E_{rr}	Diode Switching Power Dissipation	$V_{DD}=600\text{V}$ $I_D=600\text{A}$ $V_{GS}=+18/-5\text{V}$ $R_{G(ON)}=R_{G(OFF)}=5.1\Omega$ Inductive loads Switching operation	$T_j=25^\circ\text{C}$	-	0.20	-	mJ
			$T_j=150^\circ\text{C}$	-	2.07	-	

Test Conditions

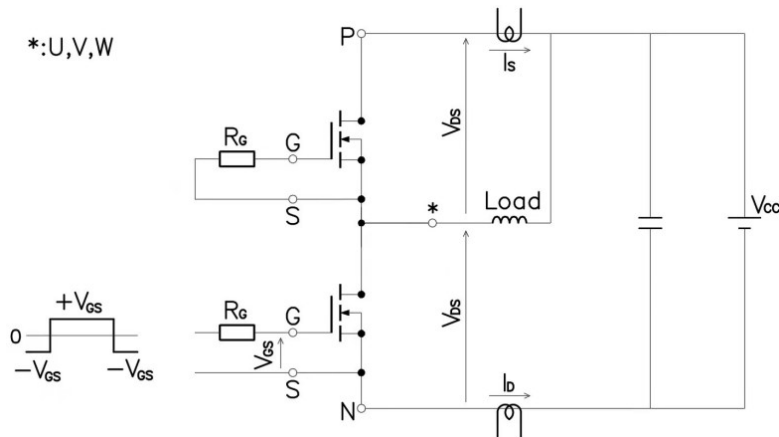

Figure 3. Switching Time Measure Circuit

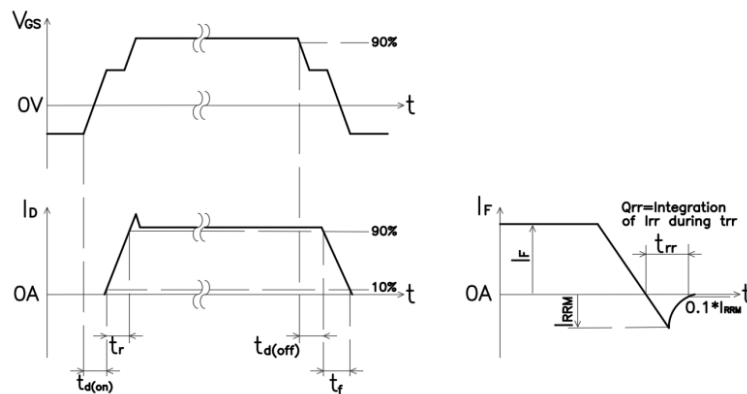

Figure 4. Switching Time Definition

HCS02FS120HDB2S

1200V/600A 3 Phase SiC MOSFET Module

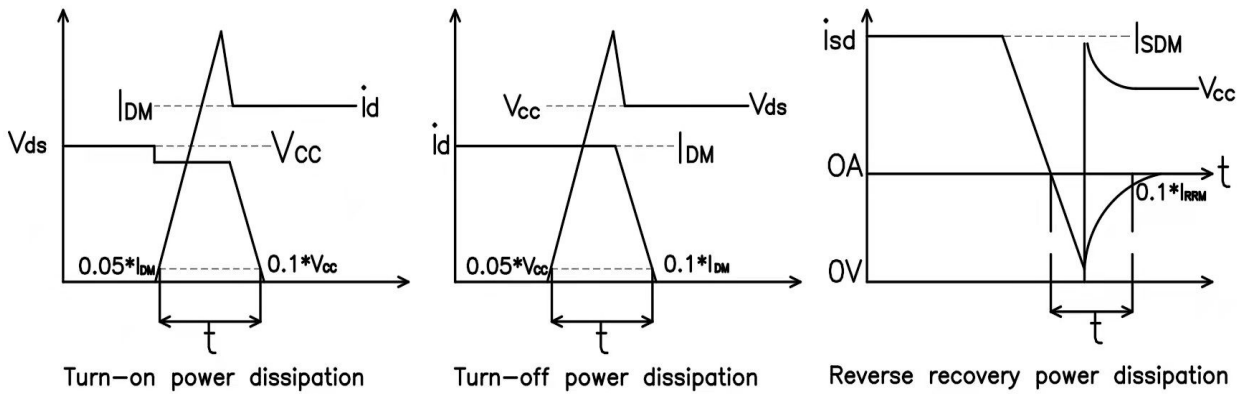
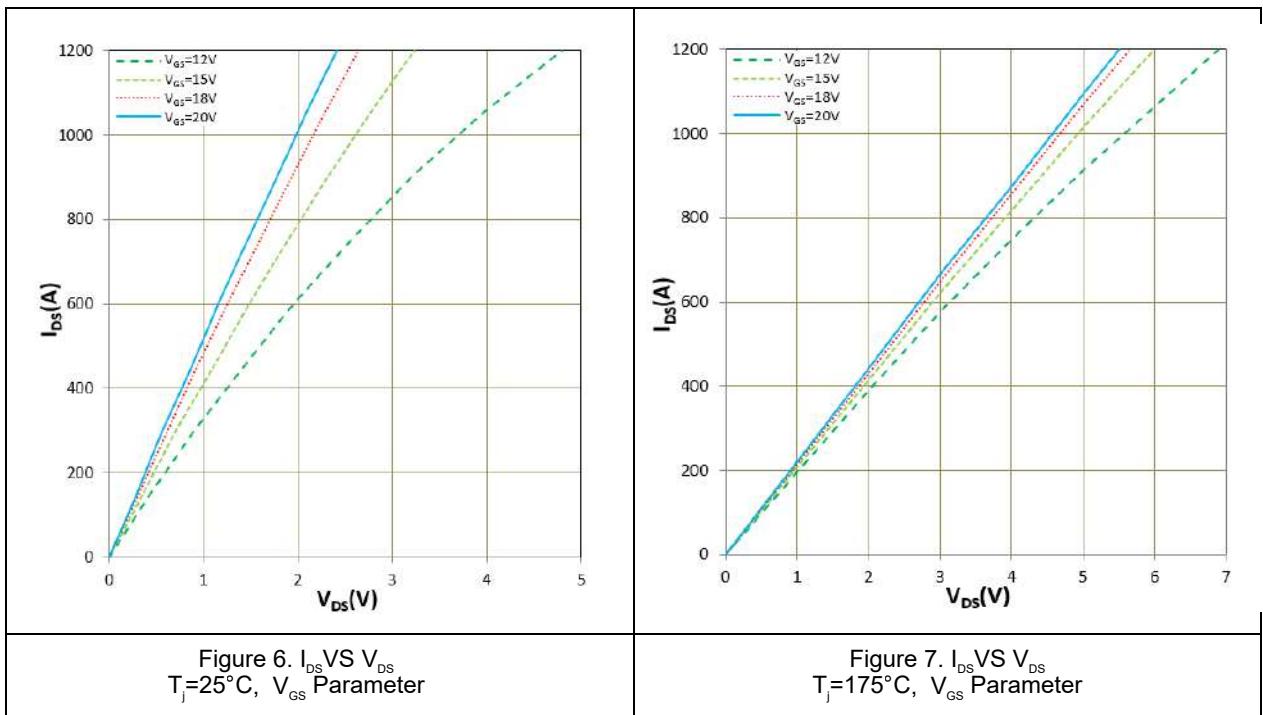

Figure 4. Switching Power Dissipation Definition



HCS02FS120HDB2S

1200V/600A 3 Phase SiC MOSFET Module

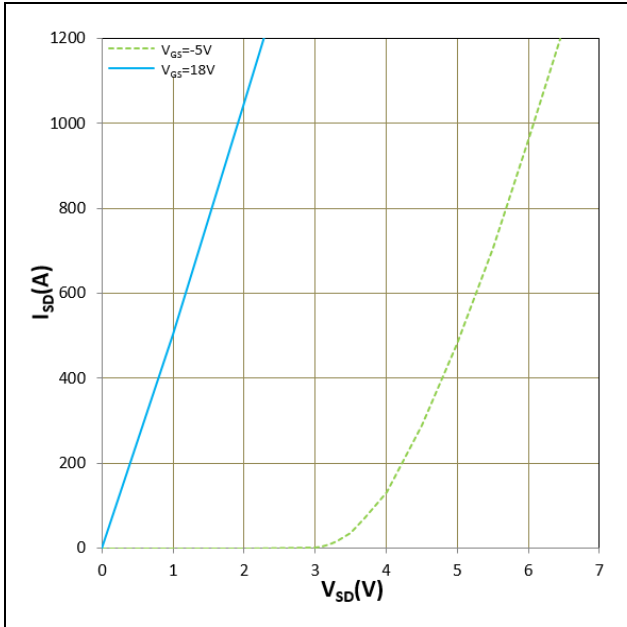

Figure 8. I_{sp} VS V_{sd}
 $T_j=25^\circ\text{C}$, V_{GS} Parameter

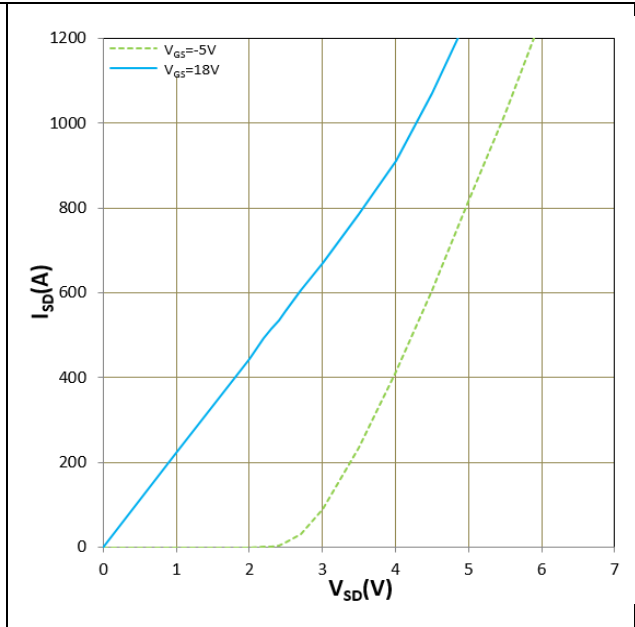

Figure 9. I_{sp} VS V_{sd}
 $T_j=175^\circ\text{C}$, V_{GS} Parameter

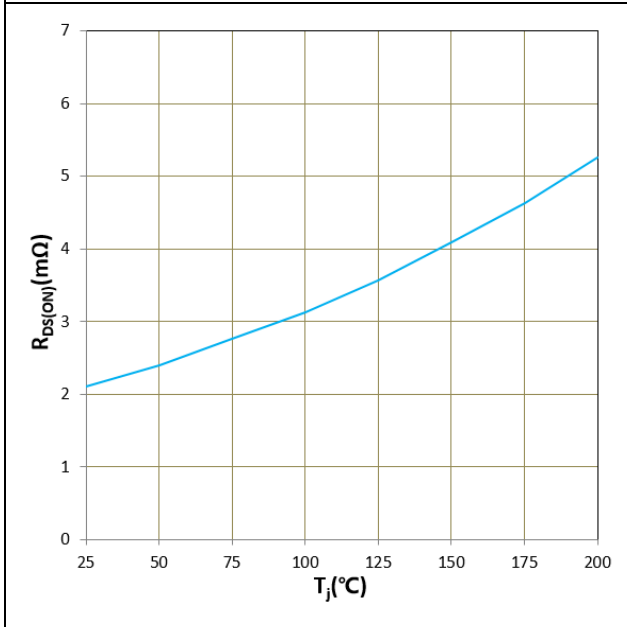

Figure 10. $R_{DS(ON)}$ VS T_j
 $V_{GS}=+18\text{V}$, $I_D=600\text{A}$

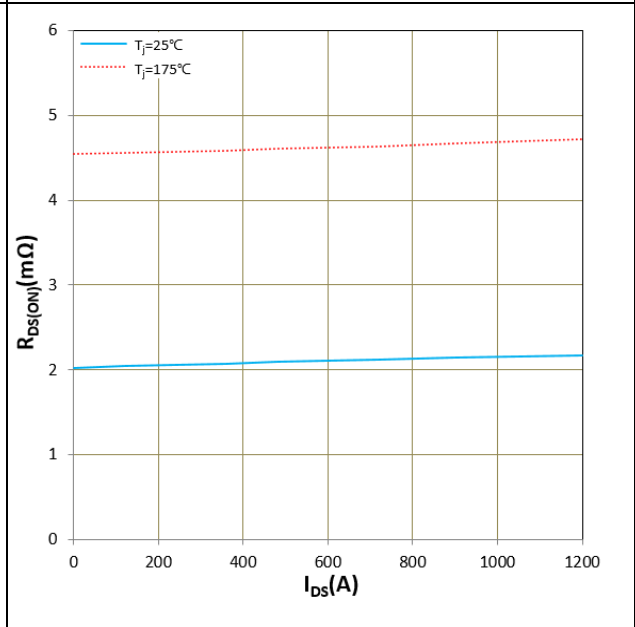

Figure 11. $R_{DS(ON)}$ VS I_{DS}
 $V_{GS}=+18\text{V}$

HCS02FS120HDB2S

1200V/600A 3 Phase SiC MOSFET Module

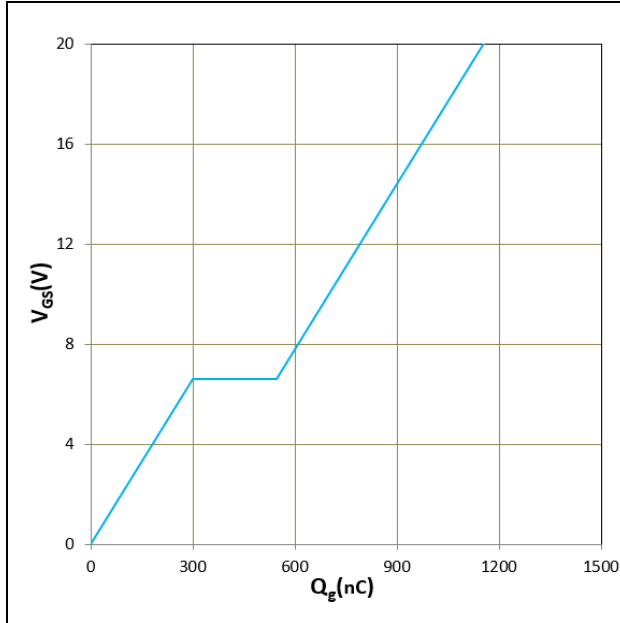

Figure 12. V_{GS} VS Q_g
 $T_j=25^\circ\text{C}$, $I_D=375\text{A}$, $V_{DS}=920\text{V}$

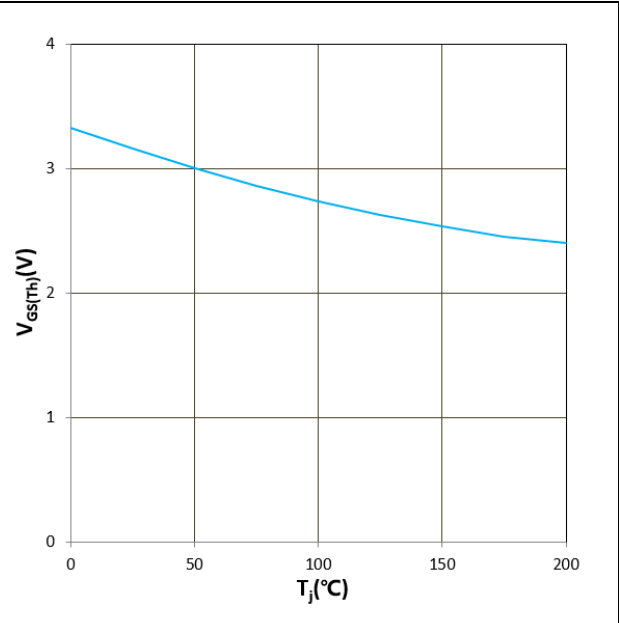

Figure 13. $V_{GS(Th)}$ VS T_j
 $V_{GS}=V_{DS}$, $I_D=60\text{mA}$

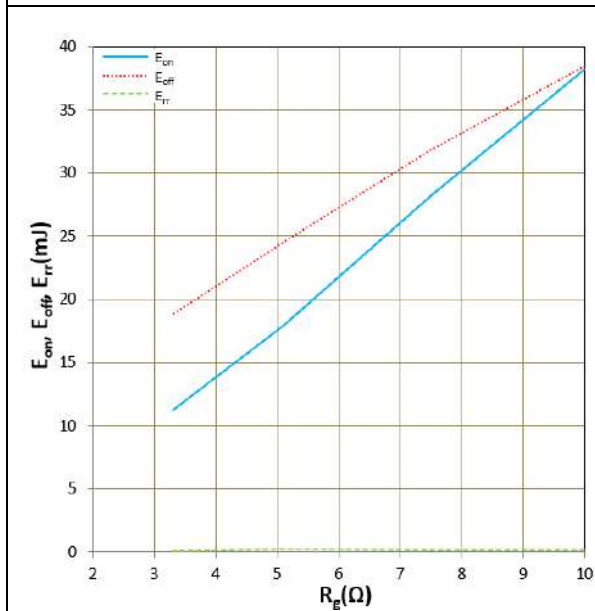

Figure 14. E_{on} , E_{off} , E_{rr} VS R_g
 $T_j=25^\circ\text{C}$, $V_{DD}=600\text{V}$, $I_D=600\text{A}$, $V_{GS}=+18\text{V}/-5\text{V}$
 Inductive Load

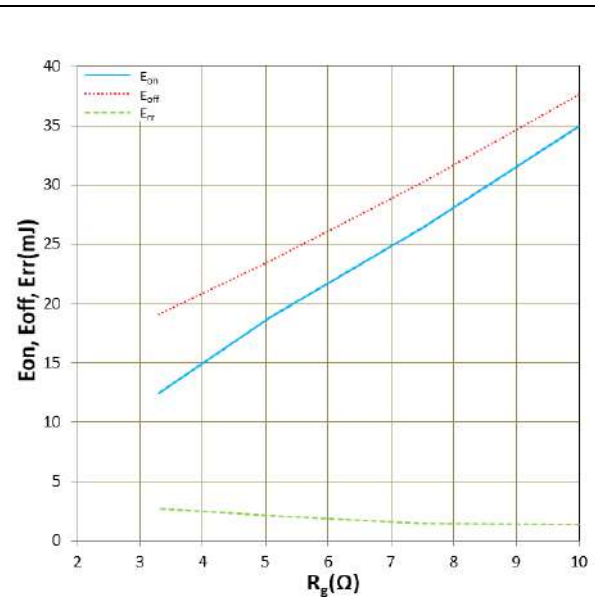

Figure 15. E_{on} , E_{off} , E_{rr} VS R_g
 $T_j=150^\circ\text{C}$, $V_{DD}=600\text{V}$, $I_D=600\text{A}$, $V_{GS}=+18\text{V}/-5\text{V}$
 Inductive Load

HCS02FS120HDB2S

1200V/600A 3 Phase SiC MOSFET Module

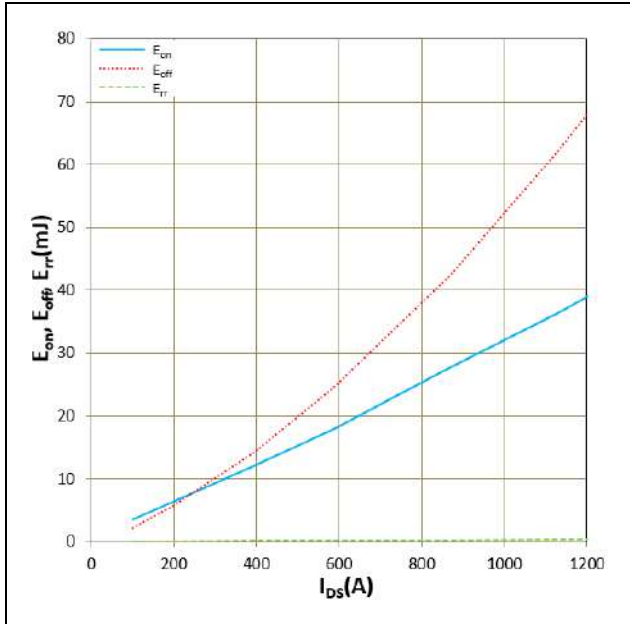

Figure 16. E_{on} , E_{off} , E_{rr} VS I_{Ds}
 $T_j=25^{\circ}C$, $V_{DD}=600V$, $R_G=5.1\Omega$, $V_{GS}=+18V/-5V$
 Inductive Load

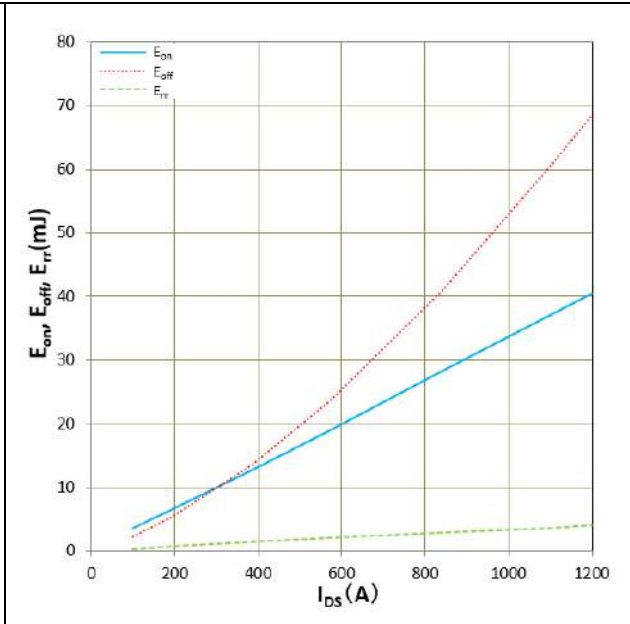

Figure 17. E_{on} , E_{off} , E_{rr} VS I_{Ds}
 $T_j=150^{\circ}C$, $V_{DD}=600V$, $R_G=5.1\Omega$, $V_{GS}=+18V/-5V$
 Inductive Load

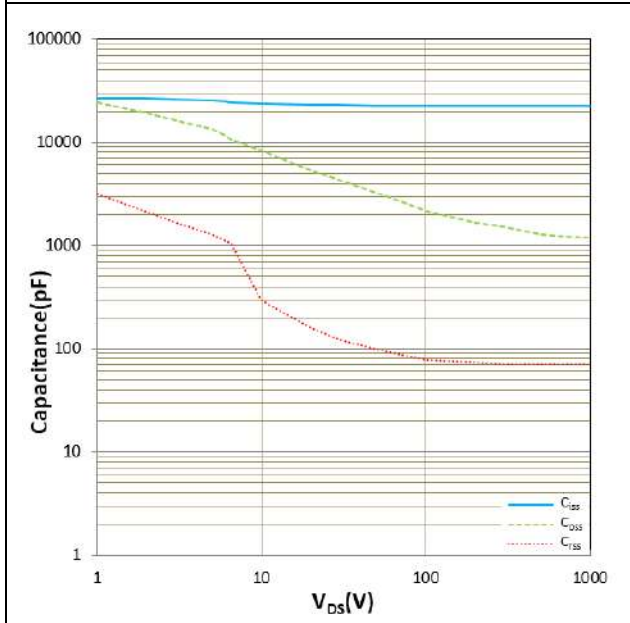

Figure 18. C_{iss} , C_{oss} , C_{rss} VS V_{Ds}
 $T_j=25^{\circ}C$, $f=100kHz$

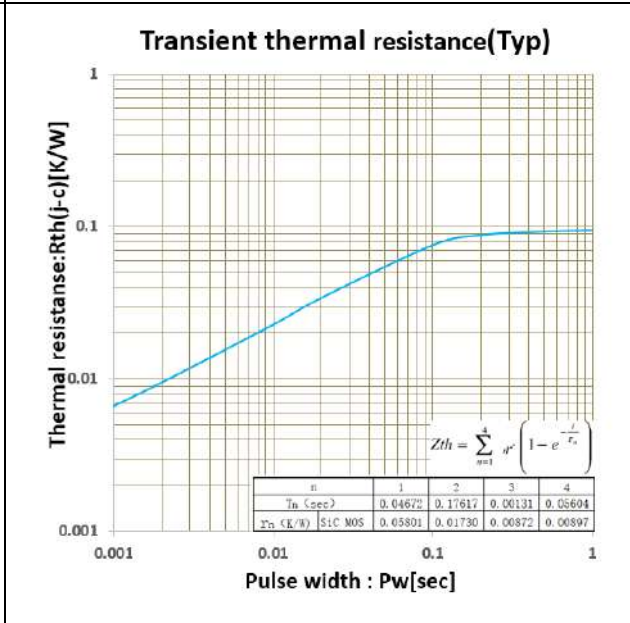

Figure 19. Transient Thermal Impedance

HCS02FS120HDB2S

1200V/600A 3 Phase SiC MOSFET Module

IMPORTANT NOTICE

This product data sheet describes the characteristics of this product for which a warranty is granted. Any such warranty is granted exclusively under the terms and conditions of the supply agreement. There will be no guarantee or of any kind for the product and its characteristics.

The data contained in this document is exclusively intended for technically trained staff. You and your technical departments will have to evaluate the product's suitability for the intended application and the completeness of the product data concerning such application.

Due to technical requirements, our product may contain dangerous substances. For information on the types in question, please contact the sales staff responsible for you.

Changes to this product data sheet are reserved.

Please contact the sales staff (sales@hiitio.com) for further information on the product, technology, delivery terms, conditions and prices.

Instruction note

Naming rules for power module product models (Industrial module)

Product Model																																							
	HC	G	02	FF	120	E3	A																																
Hecheng Code																																							
Module type G : IGBT module D : FRD module S : SiC module H : Si/SiC hybrid																																							
On-state resistance (mΩ) 01~80																																							
Topology structure FZ : A switch unit FF : Half bridge FS : Three phase F4 : H Bridge F3L : Three level DF : Boost Circuit FD : Braking Circuit FP : Rectification+Inverter+Control move AL : ANPC CL : Chopper																																							
Voltage level (x10) (V) 650~2200																																							
Packaging form+features (A...Z) <table border="0" style="width: 100%;"> <tr> <td>A1: 34 mm</td> <td>A2: 62 mm</td> <td></td> <td></td> </tr> <tr> <td>B1: Easy 1B</td> <td>B1A</td> <td></td> <td>B1B...</td> </tr> <tr> <td>B2: Easy 2B...</td> <td>B3: Easy 3B...</td> <td></td> <td></td> </tr> <tr> <td>D1: Flow0</td> <td>D2: Flow1</td> <td></td> <td>D3: Flow2</td> </tr> <tr> <td>E0 : E0</td> <td>E1: Econo 2...</td> <td></td> <td>E2: E2</td> </tr> <tr> <td>E3: ED3</td> <td>E4 : E4</td> <td></td> <td>E5 : ED3S</td> </tr> <tr> <td>E6 : EPM2</td> <td>E7 : EPM3</td> <td></td> <td>E8 : EconoPIM3</td> </tr> <tr> <td>E9 : ED3H</td> <td>F0 : F0</td> <td></td> <td>P2 : EPM2</td> </tr> </table>								A1: 34 mm	A2: 62 mm			B1: Easy 1B	B1A		B1B...	B2: Easy 2B...	B3: Easy 3B...			D1: Flow0	D2: Flow1		D3: Flow2	E0 : E0	E1: Econo 2...		E2: E2	E3: ED3	E4 : E4		E5 : ED3S	E6 : EPM2	E7 : EPM3		E8 : EconoPIM3	E9 : ED3H	F0 : F0		P2 : EPM2
A1: 34 mm	A2: 62 mm																																						
B1: Easy 1B	B1A		B1B...																																				
B2: Easy 2B...	B3: Easy 3B...																																						
D1: Flow0	D2: Flow1		D3: Flow2																																				
E0 : E0	E1: Econo 2...		E2: E2																																				
E3: ED3	E4 : E4		E5 : ED3S																																				
E6 : EPM2	E7 : EPM3		E8 : EconoPIM3																																				
E9 : ED3H	F0 : F0		P2 : EPM2																																				
Feature :A: Special Code Nil: Standard																																							

Zhejiang HIITIO New Energy Co., Ltd

ADD : NO.1125 Zhixing Road,Qiaonan District, Xiaoshan Economic and Technological Development Zone, Hangzhou, Zhejiang

TEL :400-667-9977

