

HCS600FF170E3C1

1700V/600A Half Bridge SiC MOSFET Module

Description

The HCS600FF170E3C1 is a Half Bridge SiC MOSFET Power Module. It integrates high performance SiC MOSFET chips designed for the applications such as Motor drives and Renewable energy.



Features

- Blocking voltage 1700V
- $R_{DS(on)}=3.4m\Omega@T_j=25^{\circ}C$
- Low thermal resistance with Si₃N₄AMB
- Low Inductive Design
- Thermistor inside

Applications

- xEV Applications
- Motor Drives
- Servo Drives
- Smart -Grid/Grid-Tied Distributed Generation

Circuit diagram

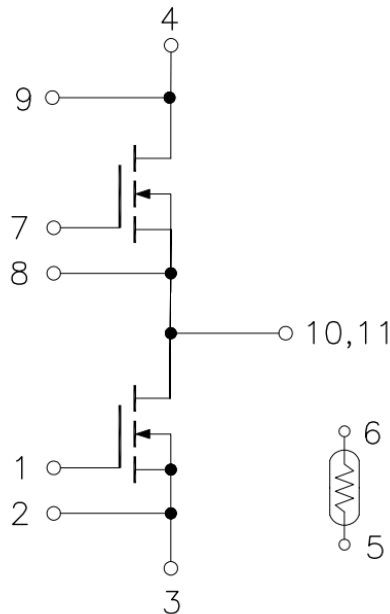

Figure 1. Out drawing & circuit diagram for HCS600FF170E3C1

HCS600FF170E3C1

1700V/600A Half Bridge SiC MOSFET Module

Module

Parameter	Condition	Value	Unit
Isolation Voltage	RMS, f=50Hz, t=1min	4.0	kV
Material of module baseplate	-	Cu	-
Creepage distance	terminal to heatsink terminal to terminal	14.5 10	mm
Clearance	terminal to heatsink terminal to terminal	12.5 10	mm
CTI	-	600	-
Module lead resistance, terminals–chip	T _C =25°C	0.5	mΩ
Mounting torque for module mounting	M5, M6	3 to 6	Nm
Weight	-	385	g

Maximum Ratings (T_j =25°C unless otherwise specified)

Symbol	Parameter	Condition	Ratings	Unit
V _{DSS}	Drain-Source Voltage	G-S Short	1700	V
V _{GSS}	Gate-Source Voltage (+)	D-S Short	20	V
V _{GSS}	Gate-Source Voltage (-)	D-S Short	-10	V
V _{GSSSurge}	G-S Voltage(t _{surge} <300nsec)	D-S Short, Note1	-10 to 20	V
I _{DS}	DC Continuous Drain Current	T _C =25°C, V _{GS} =15V	620	A
I _{DS}	DC Continuous Drain Current	T _C =60°C, V _{GS} =15V	545	A
I _{SD}	Source (Body diode) Current	T _C =25°C, with ON signal	620	A
I _{SD}	Source (Body diode) Current	T _C =60°C, with ON signal	545	A
I _{DSM}	Pulse Forward Current	T _C =25°C, Pulse width =1ms, V _{GS} =15V, Note2	1200	A
P _{tot}	Total Power Dissipation	T _C =25°C	3000	W
T _{jmax}	Max Junction Temperature	-	-55 to 175	°C
T _{stg}	Storage Temperature	-	-55 to 125	°C

Note1: Recommended Operating Value, +15V/-5V, +15V/-4V

Note2: Pulse width limited by maximum junction temperature

NTC characteristics

Symbol	Parameter	Condition	Value			Unit
			Min.	Typ.	Max.	
R ₂₅	Resistance	T _C =25°C	-	5	-	kΩ
ΔR/R	Deviation of R ₁₀₀	T _C =100°C, R ₁₀₀ =493 Ω	-5	-	5	%
P ₂₅	Power dissipation	T _C =25°C	-	-	20	mW
B _{25/50}	B-value	R ₂ =R ₂₅ exp [B _{25/50} (1/T ₂ - 1/(298,15 K))]	-	3375	-	K
B _{25/80}	B-value	R ₂ =R ₂₅ exp [B _{25/80} (1/T ₂ - 1/(298,15 K))]	-	3411	-	K
B _{25/100}	B-value	R ₂ =R ₂₅ exp [B _{25/100} (1/T ₂ - 1/(298,15 K))]	-	3433	-	K

HCS600FF170E3C1

1700V/600A Half Bridge SiC MOSFET Module

MOSFET Electrical characteristics ($T_j=25^\circ\text{C}$ unless otherwise specified, chip)

Symbol	Item	Condition	Value			Unit	
			Min.	Typ.	Max.		
$V_{(BR)DSS}$	Drain-Source Breakdown Voltage	$V_{GS}=0V, I_D=600\mu A$	1700	-	-	V	
I_{DSS}	Zero gate voltage drain Current	$V_{DS}=1700V, V_{GS}=0V$	-	-	1	mA	
I_{GSS}	Gate-Source Leakage Current	$V_{GS}=20V, V_{DS}=0V$	-	-	600	nA	
		$V_{GS}=-10V, V_{DS}=0V$	-	-	-600	nA	
$V_{GS(th)}$	Gate-source threshold Voltage	$I_D=360mA$ $V_{DS}=V_{GS}$	$T_j=25^\circ\text{C}$	1.80	2.70	-	V
			$T_j=175^\circ\text{C}$	-	1.90	-	V
$R_{DS(on)}$ (Chip)	Static drain-source	$I_D=600A$ $V_{GS}=15V$	$T_j=25^\circ\text{C}$	-	3.4	-	m Ω
	On-state resistance		$T_j=175^\circ\text{C}$	-	7.7	-	m Ω
$V_{DS(on)}$ (Chip)	Static drain-source	$I_D=600A$ $V_{GS}=15V$	$T_j=25^\circ\text{C}$	-	2.04	-	V
	On-state Voltage		$T_j=175^\circ\text{C}$	-	4.62	-	V
C_{iss}	Input Capacitance	$V_D=1000V, V_{GS}=0V$ $f=1MHz, V_{ac}=25mV$	-	45.7	-	nF	
C_{oss}	Output Capacitance		-	1.23	-	nF	
C_{rss}	Reverse transfer Capacitance		-	0.22	-	nF	
Q_g	Total gate charge	$V_{DD}=1000V$	-	1536	-	nC	
Q_{gd}	Gate-Drain Charge	$I_D=450A$	-	540	-	nC	
Q_{gs}	Gate-Source Charge	$V_{GS}=+15/-5V$	-	462	-	nC	
R_{Gint}	Internal Gate Resistance	$T_j=25^\circ\text{C}$	-	0.8	-	Ω	
$t_{d(on)}$	Turn-on delay time	$V_{DD}=900V$ $I_D=600A$ $V_{GS}=+15/-5V$ $R_{G(on)}=4.7\Omega$ $R_{G(off)}=4.7\Omega$ Inductive load switching operation	$T_j=25^\circ\text{C}$	-	162	-	ns
			$T_j=150^\circ\text{C}$	-	123	-	
t_r	Rise time		$T_j=25^\circ\text{C}$	-	112	-	ns
			$T_j=150^\circ\text{C}$	-	93	-	
$t_{d(off)}$	Turn-off delay time		$T_j=25^\circ\text{C}$	-	556	-	ns
			$T_j=150^\circ\text{C}$	-	621	-	
t_f	Fall time		$T_j=25^\circ\text{C}$	-	98	-	ns
			$T_j=150^\circ\text{C}$	-	113	-	
E_{on}	Turn-on power dissipation		$T_j=25^\circ\text{C}$	-	50.7	-	mJ
			$T_j=150^\circ\text{C}$	-	46.8	-	
E_{off}	Turn-off power dissipation	$T_j=25^\circ\text{C}$	-	57.4	-	mJ	
		$T_j=150^\circ\text{C}$	-	62.3	-		
$R_{th(j-c)}$	FET Thermal Resistance	Junction to Case	-	0.05	-	K/W	
$R_{th(c-f)}$	Contact thermal Resistance	With thermal conductive grease, Note1	-	0.015	-	K/W	

Note1: Assumes Thermal Conductivity of grease is $0.9W/m \cdot K$ and thickness is $50\mu m$.

HCS600FF170E3C1

1700V/600A Half Bridge SiC MOSFET Module

Body Diode Electrical characteristics ($T_j=25^\circ\text{C}$ unless otherwise specified, chip)

Symbol	Item	Condition	Value			Unit	
			Min.	Typ.	Max.		
V_{SD}	Body Diode Forward Voltage	$V_{GS} = -5\text{V}$ $I_{SD} = 600\text{A}$	$T_j = 25^\circ\text{C}$	-	5.6	-	V
			$T_j = 175^\circ\text{C}$	-	5.3	-	
T_{rr}	Reverse recovery time	$V_{RR} = 900\text{V}, I_D = 600\text{A}$ MOSFET side:	$T_j = 25^\circ\text{C}$	-	36	-	ns
			$T_j = 150^\circ\text{C}$	-	125	-	
Q_{rr}	Reverse recovery charge	$V_{GS} = +15/-5\text{V}$ $R_{G(on)} = R_{G(off)} = 4.7\ \Omega$	$T_j = 25^\circ\text{C}$	-	2.56	-	μC
			$T_j = 150^\circ\text{C}$	-	13.95	-	
E_{rr}	Diode switching power dissipation	Inductive load switching operation	$T_j = 25^\circ\text{C}$	-	1.0	-	mJ
			$T_j = 150^\circ\text{C}$	-	8.1	-	

Test Conditions

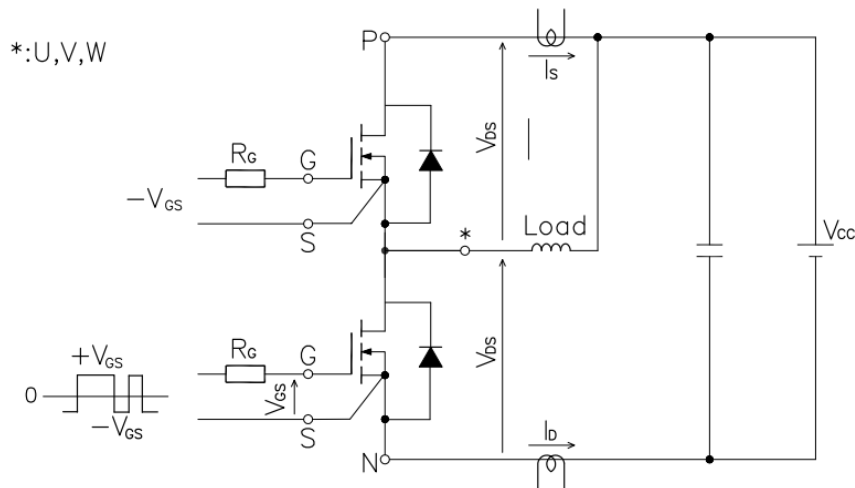

Figure 3. Switching time measure circuit

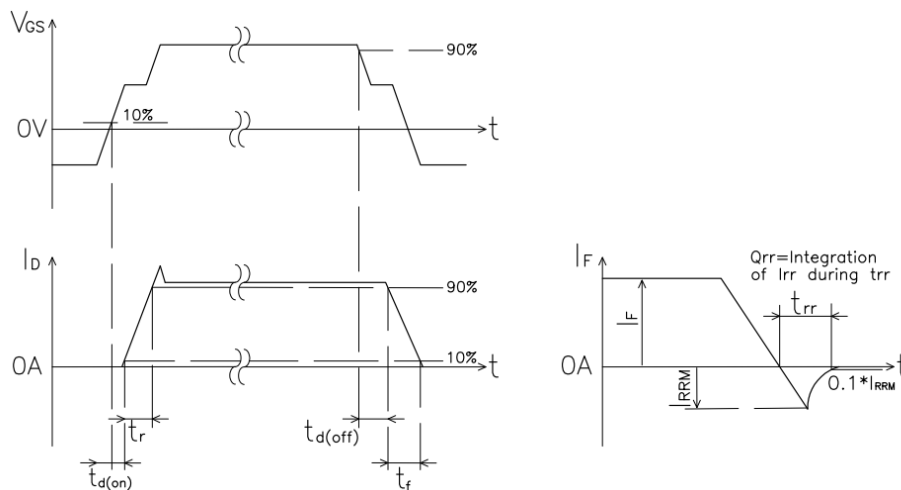

Figure 4. Switching time definition

HCS600FF170E3C1

1700V/600A Half Bridge SiC MOSFET Module

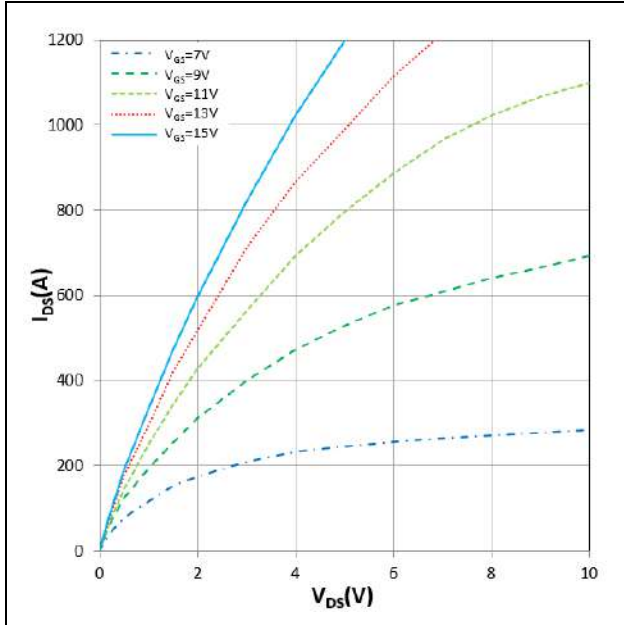

Figure 5. I_{DS} vs V_{DS}
 $T_J = 25^\circ\text{C}$, V_{GS} parameter

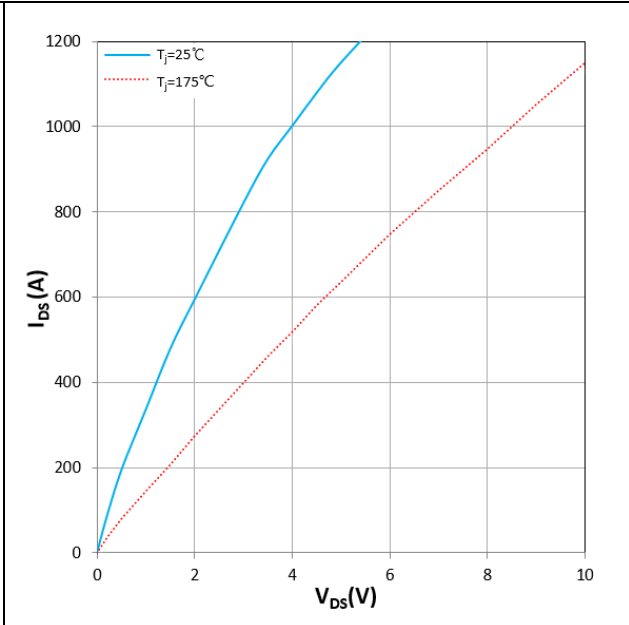

Figure 6. I_{DS} vs V_{DS}
 $V_{GS} = 15\text{V}$, T_J parameter

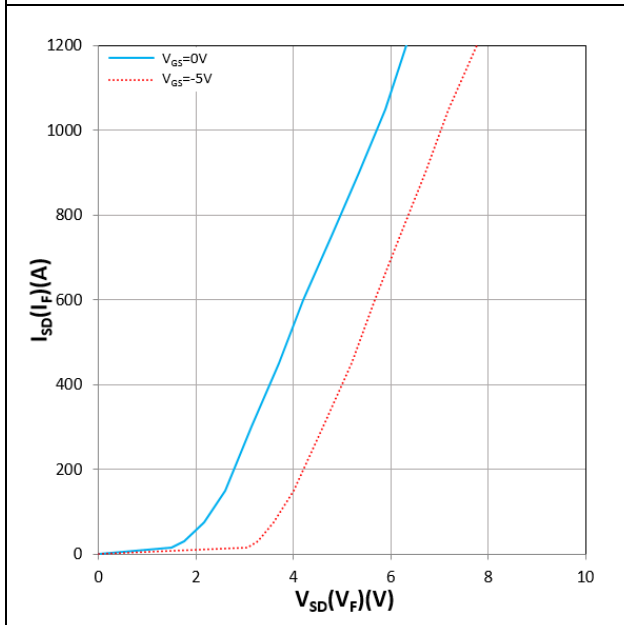

Figure 7. $I_{SD}(I_F)$ vs $V_{SD}(V_F)$
 $T_J = 25^\circ\text{C}$, V_{GS} parameter

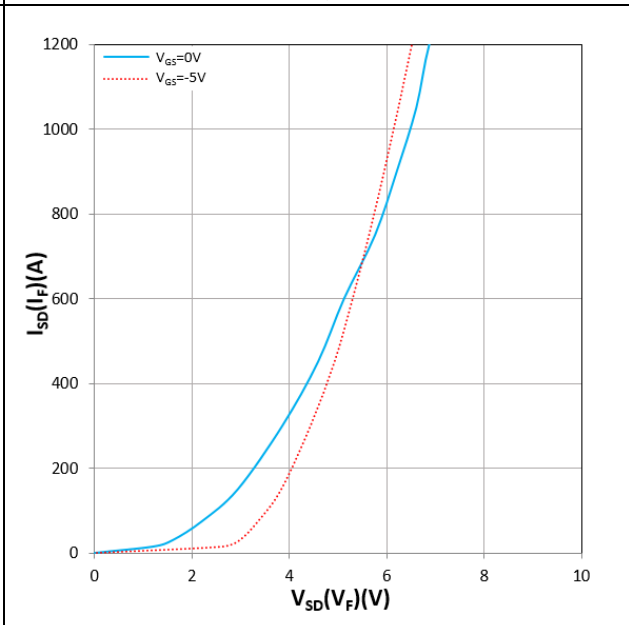

Figure 8. $I_{SD}(I_F)$ vs $V_{SD}(V_F)$
 $T_J = 175^\circ\text{C}$, V_{GS} parameter

HCS600FF170E3C1

1700V/600A Half Bridge SiC MOSFET Module

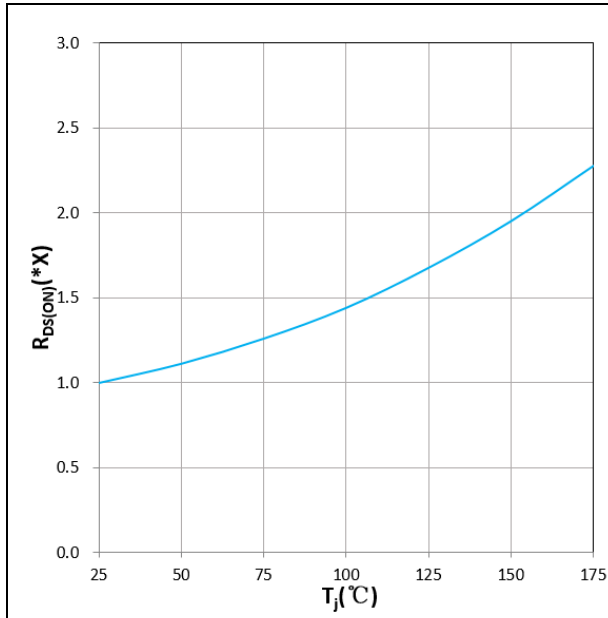

Figure 9. $R_{DS(ON)}$ vs T_j
 $V_{GS} = +15V$, $I_D = 600A$, $1.0X = 3.4m\Omega$

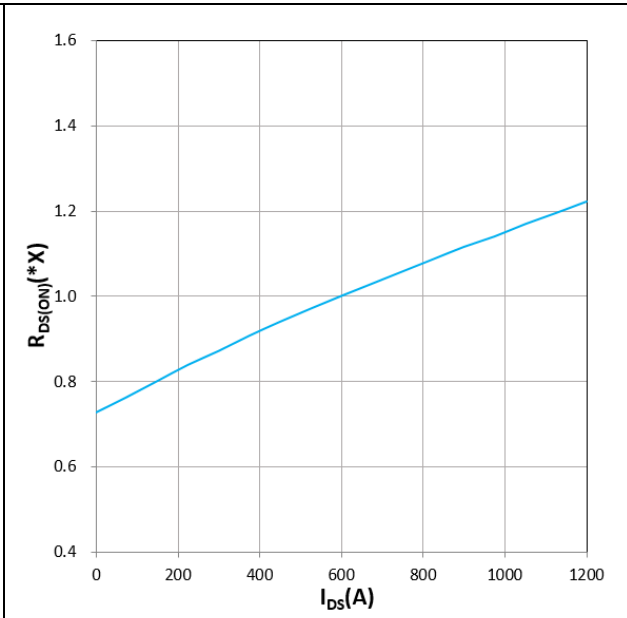

Figure 10. $R_{DS(ON)}$ vs I_{DS}
 $T_j = 25^\circ C$, $V_{GS} = +15V$, $1.0X = 3.4m\Omega$

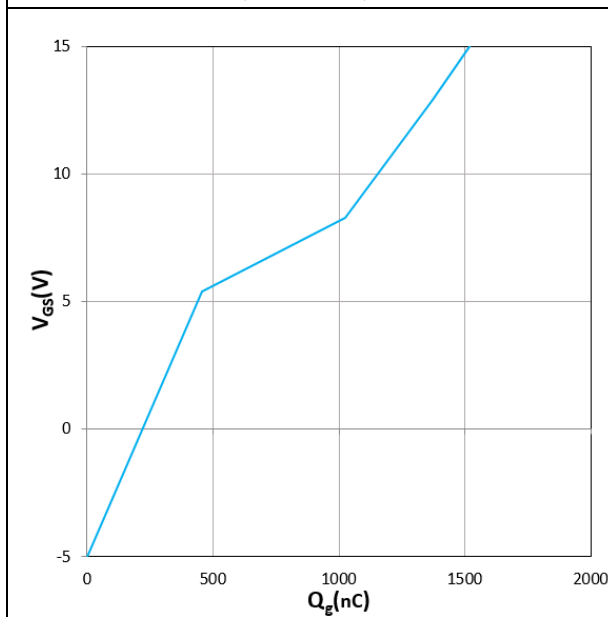

Figure 11. V_{GS} vs Q_g
 $T_j = 25^\circ C$, $V_{DS} = 1000V$, $I_D = 450A$

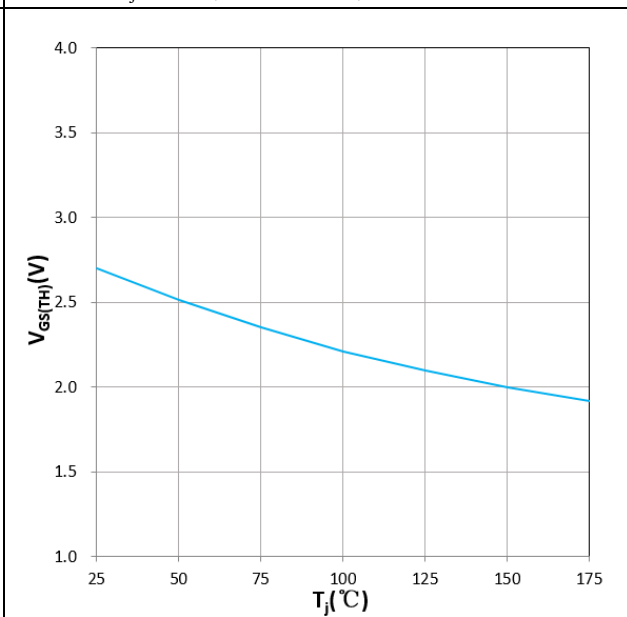
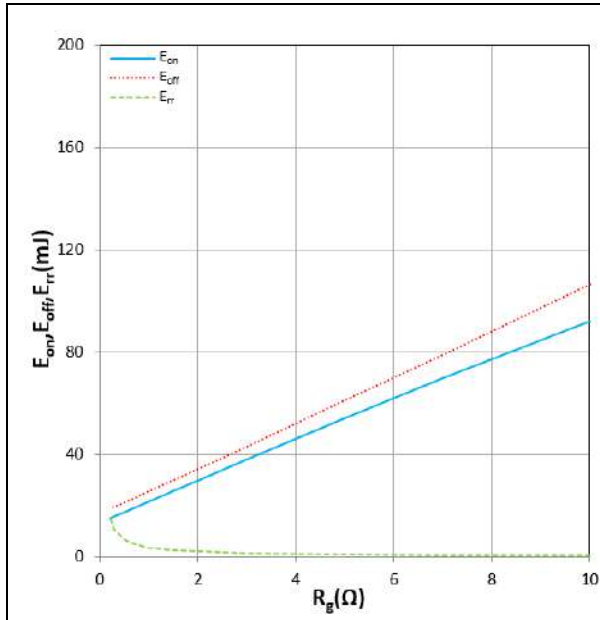

Figure 12. $V_{GS(TH)}$ vs T_j
 $V_{GS} = V_{DS}$, $I_D = 360mA$

HCS600FF170E3C1

1700V/600A Half Bridge SiC MOSFET Module

 Figure 13. E_{on} , E_{off} , E_{rr} vs R_g
 $T_j=25^{\circ}\text{C}$, $V_{DD}=900\text{V}$, $V_{GS}=+15\text{V}/-5\text{V}$, $I_D=600\text{A}$

Inductive Load

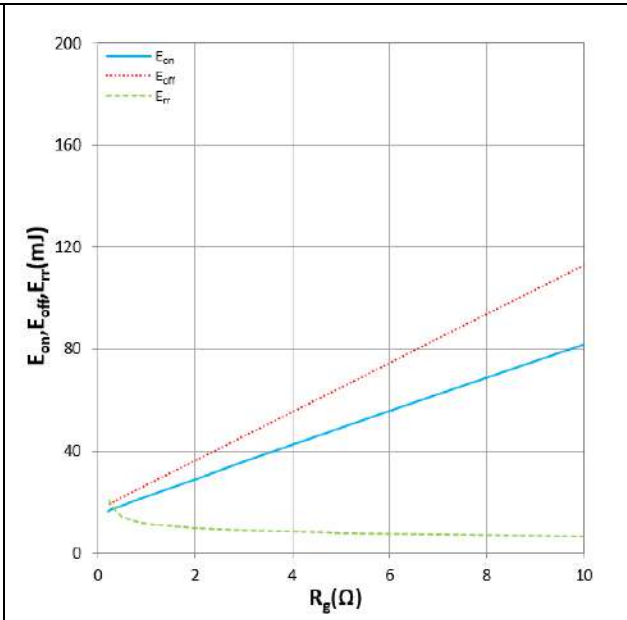
 Figure 14. E_{on} , E_{off} , E_{rr} vs R_g
 $T_j=150^{\circ}\text{C}$, $V_{DD}=900\text{V}$, $V_{GS}=+15\text{V}/-5\text{V}$, $I_D=600\text{A}$

Inductive Load

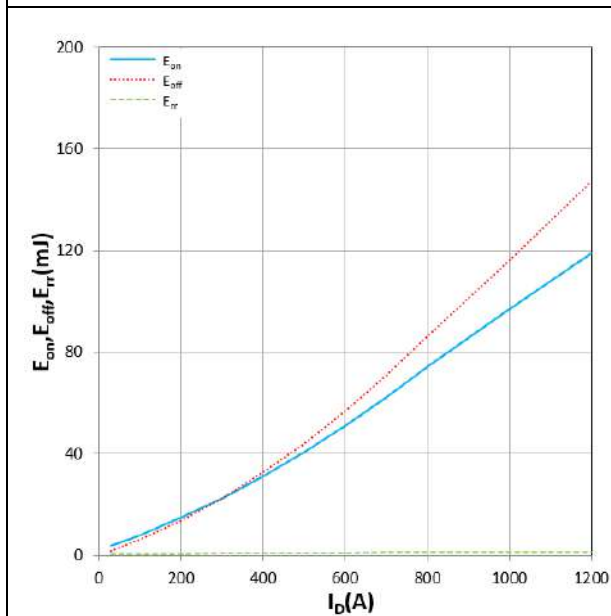
 Figure 15. E_{on} , E_{off} , E_{rr} vs I_D
 $T_j=25^{\circ}\text{C}$, $V_{DD}=900\text{V}$, $V_{GS}=+15\text{V}/-5\text{V}$, $R_g=4.7\Omega$

Inductive Load

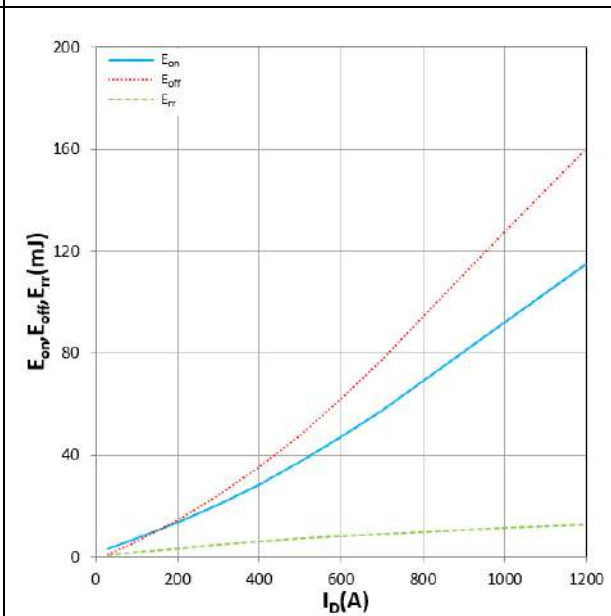
 Figure 16. E_{on} , E_{off} , E_{rr} vs I_D
 $T_j=150^{\circ}\text{C}$, $V_{DD}=900\text{V}$, $V_{GS}=+15\text{V}/-5\text{V}$, $R_g=4.7\Omega$

Inductive Load

HCS600FF170E3C1

1700V/600A Half Bridge SiC MOSFET Module

IMPORTANT NOTICE

This product data sheet describes the characteristics of this product for which a warranty is granted. Any such warranty is granted exclusively under the terms and conditions of the supply agreement. There will be no guarantee or of any kind for the product and its characteristics.

The data contained in this document is exclusively intended for technically trained staff. You and your technical departments will have to evaluate the product's suitability for the intended application and the completeness of the product data concerning such application.

Due to technical requirements, our product may contain dangerous substances. For information on the types in question, please contact the sales staff responsible for you.

Changes to this product data sheet are reserved.

Please contact the sales staff (sales@hiitio.com) for further information on the product, technology, delivery terms, conditions and prices.

Instruction note

Naming rules for power module product models (Industrial module)

Product Model							
	HC	G	100	FF	120	E3	A
Hecheng Code							
Module type G : IGBT module D : FRD module S : SiC module H : Si/SiC hybrid							
Current level (A) 50~900							
Topology structure FZ : A switch unit FF : Half bridge FS : Three phase F4 : H Bridge F3L : Three level DF : Boost Circuit FD : Braking Circuit FP : Rectification+Inverter+Control move AL : ANPC CL : Chopper							
Voltage level (x10) (V) 650~2200							
Packaging form+features (A...Z) A1: 34 mm A2: 62 mm B1: Easy 1B B1A B1B... B2: Easy 2B... B3: Easy 3B... D1: Flow0 D2: Flow1 D3: Flow2 E0 : E0 E1: Econo 2... E2: E2 E3: ED3 E4 : E4 E5 : ED3S E6 : EPM2 E7 : EPM3 E8 : EconoPIM3 E9 : ED3H F0 : F0 P2 : EPM2							
Feature :A: Special Code Nil: Standard							

Zhejiang HIITIO New Energy Co., Ltd

ADD : NO.1125 Zhixing Road,Qiaonan District, Xiaoshan Economic and Technological Development Zone, Hangzhou, Zhejiang

TEL :400-667-9977

