

# HCG300FH170D3RE1

## 1700V/300A Half Bridge IGBT Module

### Description

The HCG300FH170D3RE1 is a Half Bridge IGBT Power Module. It integrates high performance IGBT chips designed for the applications such as High Power supply and Motor control.

### Features

- Blocking voltage 1700V
- Low saturation voltage  $V_{CE(sat)}$
- Low Switching Losses
- 175°C maximum junction temperature
- Thermistor inside

### Applications

- HighPowerSwitchingApplications
- MotorDrives
- SolarinverterSystems
- WindTurbines



### Circuit diagram

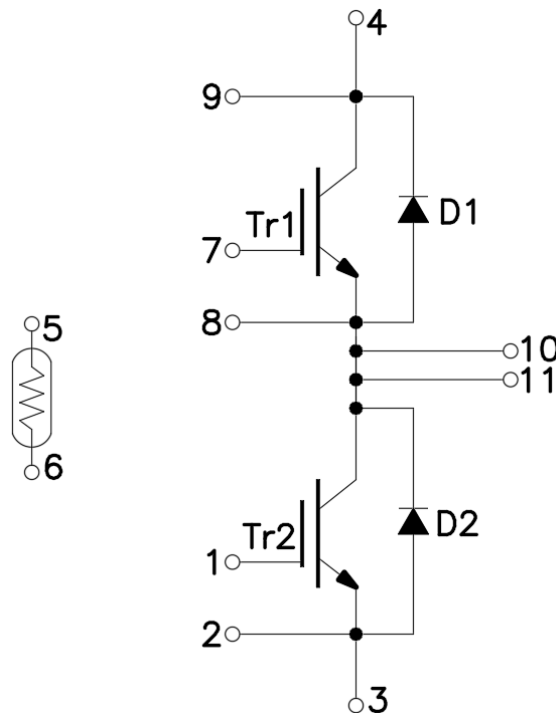

Figure 1. Out drawing & circuit diagram for HCG300FH170D3RE1

**HCG300FH170D3RE1**

1700V/300A Half Bridge IGBT Module

**Pin Configuration and Marking Information**

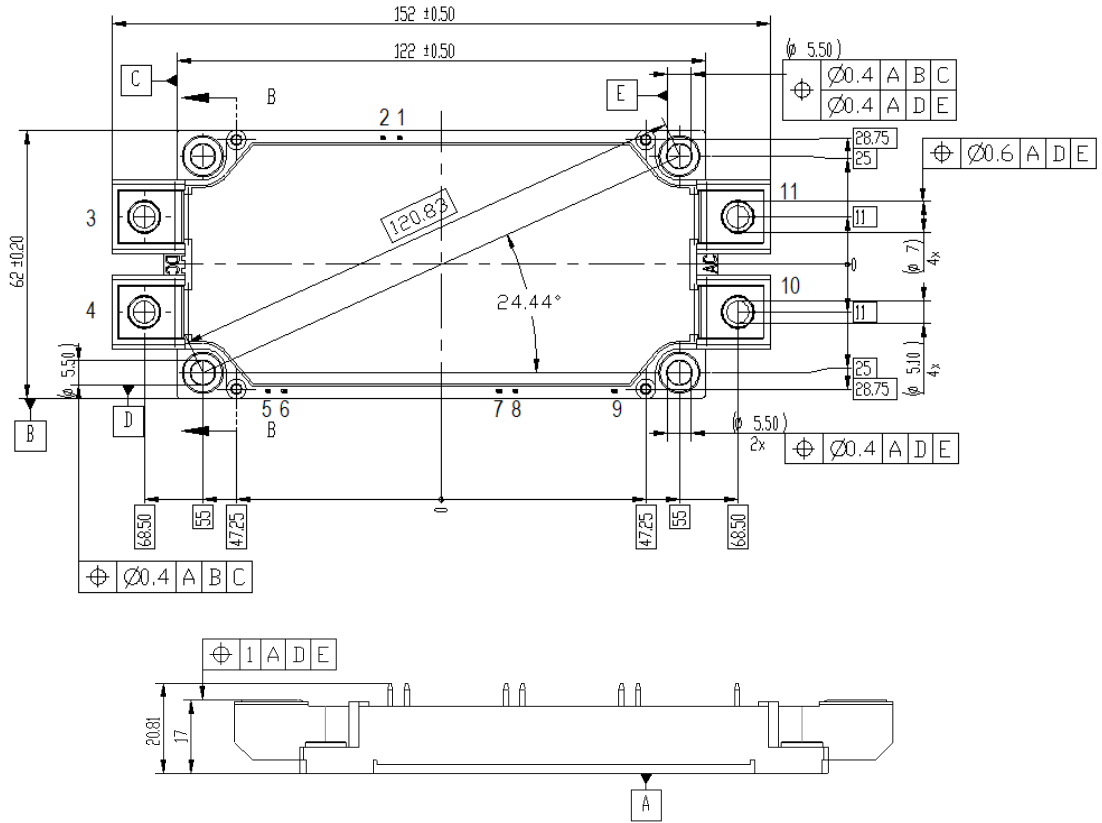

Figure 2. Pin configuration

## HCG300FH170D3RE1

### 1700V/300A Half Bridge IGBT Module

#### Module

Parameter	Conditions	Value	Unit
Isolation voltage	RMS, f =50Hz, t =1min	4.0	KV
Material of module baseplate	-	Cu	-
Creepage distance	terminal to heatsink terminal to terminal	14.5 13	mm
Clearance	terminal to heatsink terminal to terminal	12.5 10	mm
CTI	-	>225	-
Module lead resistance, terminals – chip	T <sub>C</sub> =25°C	0.8	mΩ
Mounting torque for module mounting	M5, M6	3 to 6	Nm
Weight	-	420	g

#### Maximum Ratings (T<sub>j</sub> =25°C unless otherwise specified)

Symbol	Parameter	Conditions	Ratings	Unit
V <sub>CES</sub>	Collector-Emitter Voltage	G-E Short	1700	V
V <sub>GES</sub>	Gate-Emitter Voltage	C-E Short	±20	V
I <sub>C</sub>	DC Continuous Collector Current	T <sub>C</sub> =100°C	320	A
I <sub>CM</sub>	Pulse Collector Current	t <sub>p</sub> =1ms, Note1	600	A
P <sub>C</sub>	Maximum Power Dissipation	T <sub>C</sub> =25°C, T <sub>j</sub> =150°C(IGBT)	2083	W
I <sub>F</sub>	Diode Forward Current	-	300	A
I <sub>FRM</sub>	Repetitive peak forward current	t <sub>p</sub> =1ms, Note1	600	A
I <sup>2</sup> t	I <sup>2</sup> t-value	V <sub>R</sub> =0V, t <sub>p</sub> =10ms, T <sub>j</sub> =125°C(Diode)	14000	A <sup>2</sup> s
T <sub>jmax</sub>	Max junction temperature	-	175	°C
T <sub>jop</sub>	Operating junction temperature	-	-40 to 150	°C
T <sub>stg</sub>	Storage temperature	-	-40 to 125	°C

Note1: Pulse width limited by maximum junction temperature

#### NTC characteristics

Symbol	Parameter	Condition	Value			Unit
			Min.	Typ.	Max.	
R <sub>25</sub>	Resistance	T <sub>C</sub> =25°C	-	5	-	kΩ
ΔR/R	Deviation of R100	T <sub>C</sub> =100°C, R <sub>100</sub> =493Ω	-5	-	5	%
P <sub>25</sub>	Power dissipation	T <sub>C</sub> =25°C	-	-	20	mW
B <sub>25/50</sub>	B-value	R <sub>2</sub> =R <sub>25</sub> exp [B <sub>25/50</sub> (1/T <sub>2</sub> - 1/(298,15 K))]	-	3375	-	K
B <sub>25/80</sub>	B-value	R <sub>2</sub> =R <sub>25</sub> exp [B <sub>25/80</sub> (1/T <sub>2</sub> - 1/(298,15 K))]	-	3411	-	K
B <sub>25/100</sub>	B-value	R <sub>2</sub> =R <sub>25</sub> exp [B <sub>25/100</sub> (1/T <sub>2</sub> - 1/(298,15 K))]	-	3433	-	K

## HCG300FH170D3RE1

### 1700V/300A Half Bridge IGBT Module

#### IGBT Electrical characteristics ( $T_j=25^\circ\text{C}$ unless otherwise specified, chip: Target)

Symbol	Item	Condition		Value			Unit	
				Min.	Typ.	Max		
$V_{CE(sat)}$ (Chip)	Collector-Emitter Saturation Voltage	$I_C=300\text{A}$ $V_{GE}=15\text{V}$	$T_j=25^\circ\text{C}$	-	1.6	1.9	V	
			$T_j=125^\circ\text{C}$	-	1.95	-	V	
			$T_j=150^\circ\text{C}$	-	2.03	-	V	
$V_{GE(th)}$	Gate-Emitter threshold Voltage	$I_C=12\text{mA}, V_{CE}=V_{GE}$		5.2	5.8	6.4	V	
$Q_G$	Gate charge	$V_{GE} = -15\text{V to } +15\text{V}$		-	3.1	-	$\mu\text{C}$	
$R_{Gint}$	Internal gate resistor	-	$T_j=25^\circ\text{C}$	-	3.3	-	$\Omega$	
$C_{ies}$	Input Capacitance	$V_{CE}=25\text{V}, V_{GE}$ $=0\text{V } f=1\text{MHz}$	$T_j=25^\circ\text{C}$	-	24	-	nF	
$C_{res}$	Reverse transfer Capacitance			-	0.77	-	nF	
$I_{CES}$	Collector- Emitter Cut off Current	$V_{CE}=1700\text{V}, V_{GE}=0\text{V}$	$T_j=25^\circ\text{C}$	-	-	1	mA	
$I_{GES}$	Gate-Emitter Leakage Current	$V_{GE}=20\text{V}, V_{CE}=0\text{V}$	$T_j=25^\circ\text{C}$	-	-	0.9	$\mu\text{A}$	
$t_{d(on)}$	Turn-on delay time	$V_{CC}=900\text{V}$ $I_C=300\text{A}$ $V_{GE}=+15\text{V}/-8\text{V}$ $R_G=3.3\Omega$ Inductive load	$T_j=25^\circ\text{C}$	-	324	-	ns	
			$T_j=150^\circ\text{C}$	-	348	-		
$t_r$	Rise time		$T_j=25^\circ\text{C}$	-	166	-	ns	
			$T_j=150^\circ\text{C}$	-	201	-		
$t_{d(off)}$	Turn-off delay time		$T_j=25^\circ\text{C}$	-	588	-	ns	
			$T_j=150^\circ\text{C}$	-	709	-		
$t_f$	Fall time		$T_j=25^\circ\text{C}$	-	388	-	ns	
			$T_j=150^\circ\text{C}$	-	662	-		
$E_{on}$	Turn-on power dissipation		$T_j=25^\circ\text{C}$	-	188.2	-	mJ	
			$T_j=150^\circ\text{C}$	-	217.3	-		
$E_{off}$	Turn-off power dissipation		$T_j=25^\circ\text{C}$	-	94.2	-	mJ	
			$T_j=150^\circ\text{C}$	-	102.7	-		
$I_{sc}$	SC data		$V_{GE}<15\text{V}$ $V_{CC}=1000\text{V}$	$T_j=150^\circ\text{C}$ $t_p<10\mu\text{s}$	-	1600	-	A
$R_{th(j-c)}$	Thermal Resistance, Junction to Case(IGBT)			-	0.06	-	$^\circ\text{C/W}$	
$R_{th(c-s)}$	Thermal Resistance, Case to sink(Conductive Grease applied)			-	0.015	-	$^\circ\text{C/W}$	

# HCG300FH170D3RE1

## 1700V/300A Half Bridge IGBT Module

### Freewheeling Diode Electrical characteristics (T<sub>j</sub>=25°C unless otherwise specified, chip)

Symbol	Item	Condition	Value			Unit	
			Min.	Typ.	Max		
V <sub>F</sub>	Diode Forward Voltage	I <sub>F</sub> = 300A V <sub>GE</sub> = 0V	T <sub>j</sub> = 25°C	-	1.76	2.0	V
			T <sub>j</sub> = 150°C	-	1.74	-	
t <sub>rr</sub>	Reverse recovery time	(Switch side) V <sub>CC</sub> = 900V, I <sub>C</sub> = 300A V <sub>GE</sub> = +15V/-8V	T <sub>j</sub> = 25°C	-	1.06	-	us
			T <sub>j</sub> = 150°C	-	1.53	-	
I <sub>RM</sub>	Peak reverse recovery Current	R <sub>G</sub> = 3.3Ω (FRD side)	T <sub>j</sub> = 25°C	-	131	-	A
			T <sub>j</sub> = 150°C	-	168	-	
Q <sub>rr</sub>	Recovered charge	V <sub>rr</sub> = 900V, I <sub>F</sub> = 300A V <sub>GE</sub> = +15V/-8V	T <sub>j</sub> = 25°C	-	52	-	uC
			T <sub>j</sub> = 150°C	-	129	-	
E <sub>rr</sub>	Reverse recovered energy	Inductive load switching operation	T <sub>j</sub> = 25°C	-	48.0	-	mJ
			T <sub>j</sub> = 150°C	-	63.8	-	
R <sub>th(j-c)</sub>	Thermal Resistance, Junction to Case (Diode)		-	0.09	-	°C/W	
R <sub>th(c-s)</sub>	Thermal Resistance, Case to sink (Conductive Grease applied)		-	0.015	-	°C/W	

### Test Conditions

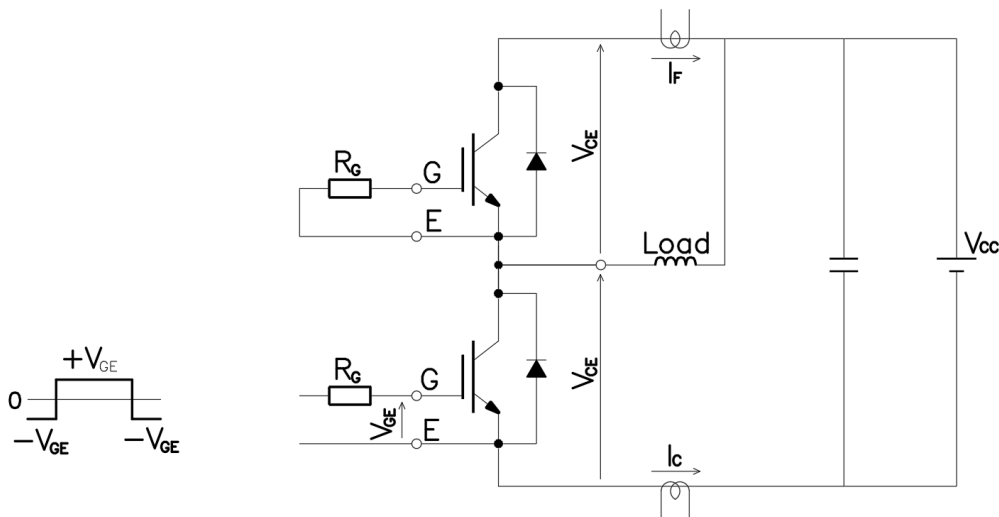

Figure 3. Switching time measure circuit

**HCG300FH170D3RE1**

**1700V/300A Half Bridge IGBT Module**

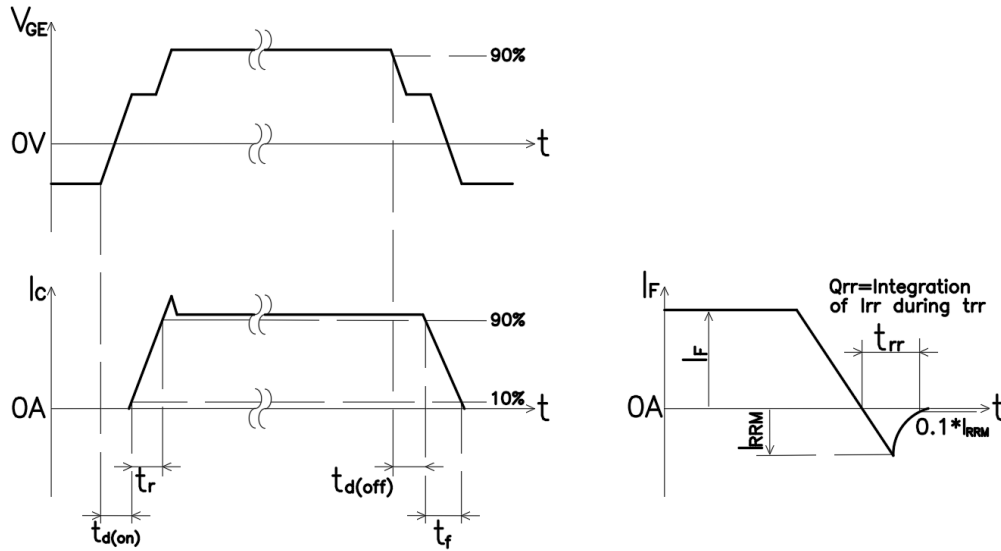
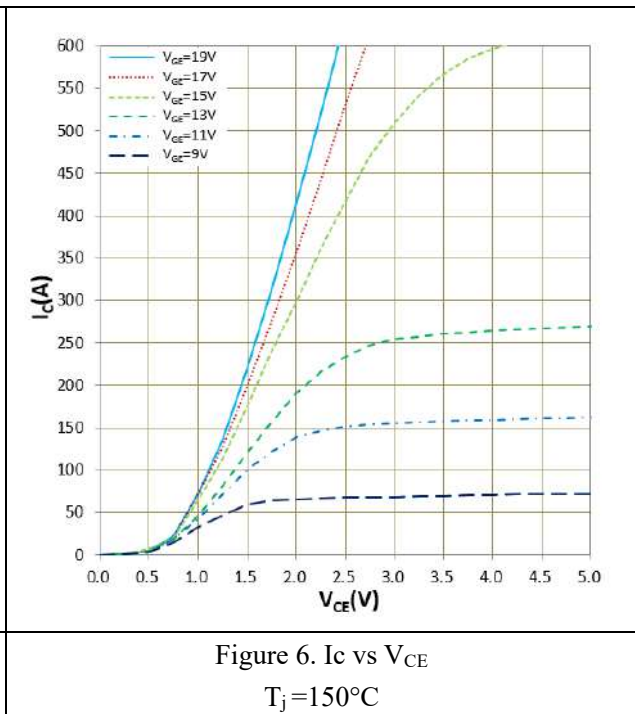
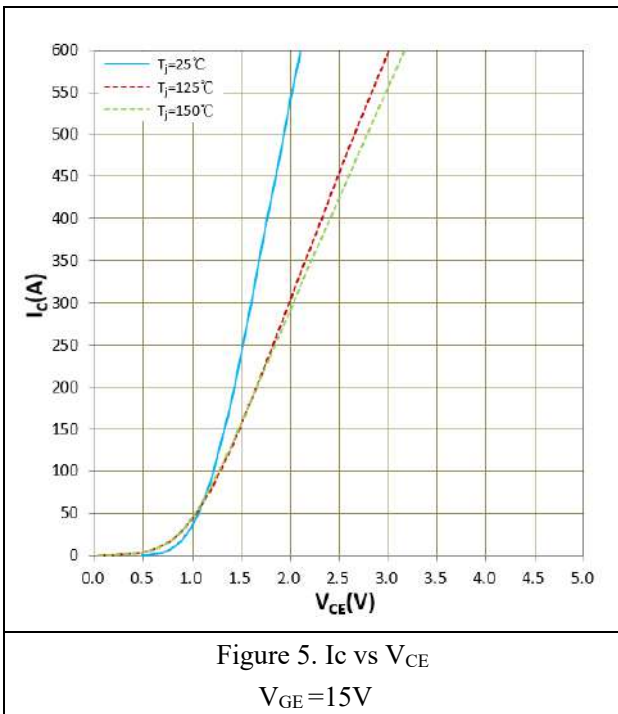

Figure 4. Switching time definition



# HCG300FH170D3RE1

## 1700V/300A Half Bridge IGBT Module

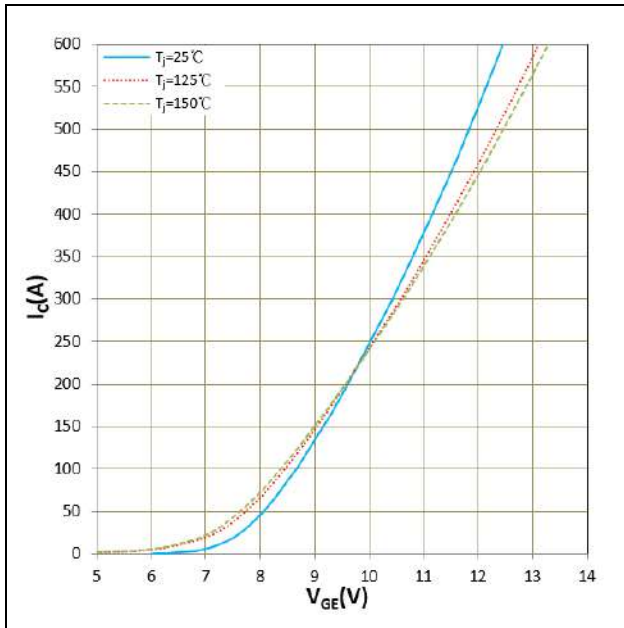

Figure 7.  $I_c$  vs  $V_{GE}$   
 $V_{CE}=20V$

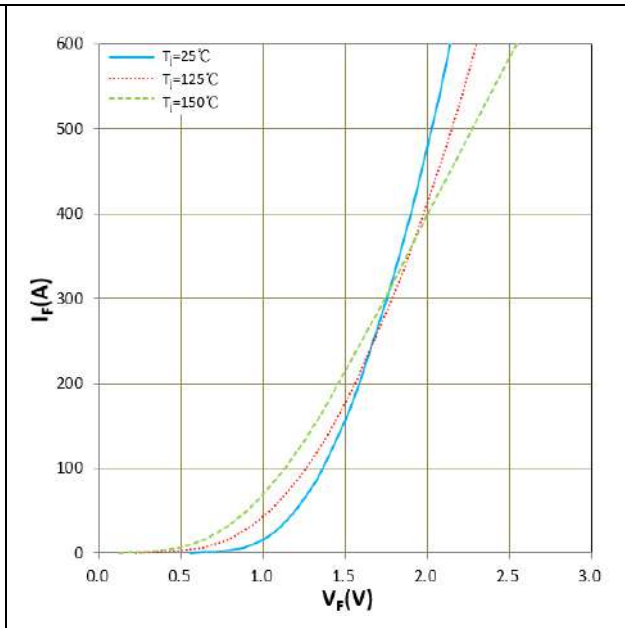

Figure 8.  $I_F$  vs  $V_F$

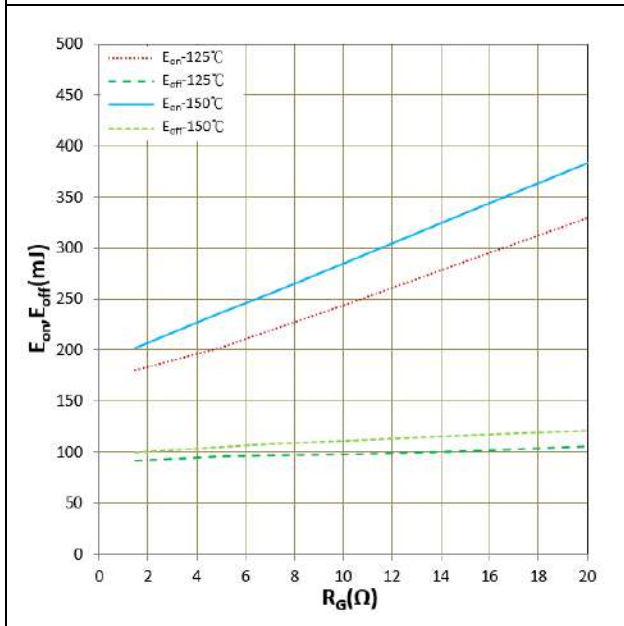

Figure 9.  $E_{on}$ ,  $E_{off}$  vs  $R_G$ (Typ)  
 $V_{CC}=900V$ ,  $V_{GE}=+15V/-8V$ ,  $I_C=300A$   
Inductive Load

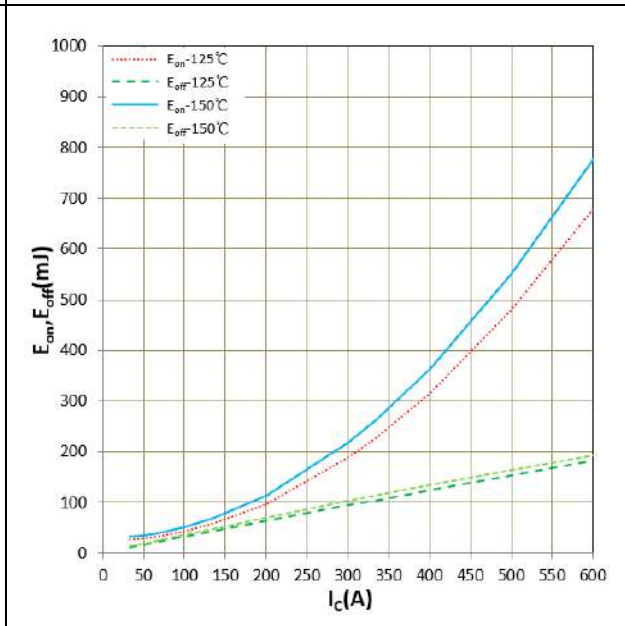

Figure 10.  $E_{on}$ ,  $E_{off}$  vs  $I_c$ (Typ)  
 $V_{CC}=900V$ ,  $V_{GE}=+15V/-8V$ ,  $R_G=3.3\Omega$   
Inductive Load

# HCG300FH170D3RE1

## 1700V/300A Half Bridge IGBT Module

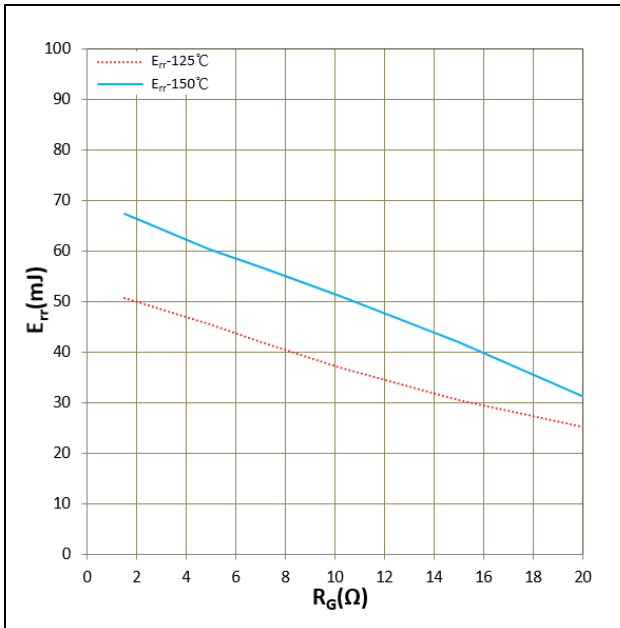

Figure 11. Err vs  $R_G$ (Typ)  
 $V_{CC}=900V$ ,  $V_{GE}=+15V/-8V$ ,  $I_F=300A$   
 Inductive Load

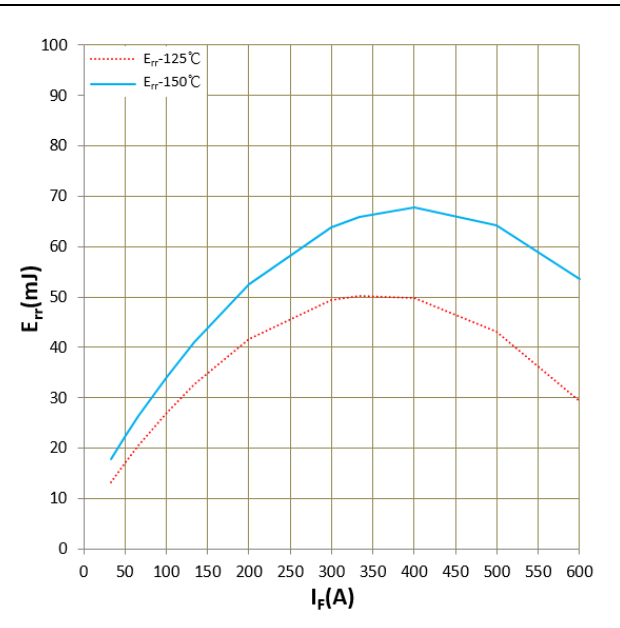

Figure 12.  $E_{rr}$  vs  $I_F$ (Typ)  
 $V_{CC}=900V$ ,  $V_{GE}=+15V/-8V$ ,  $R_G=3.3\Omega$   
 Inductive Load

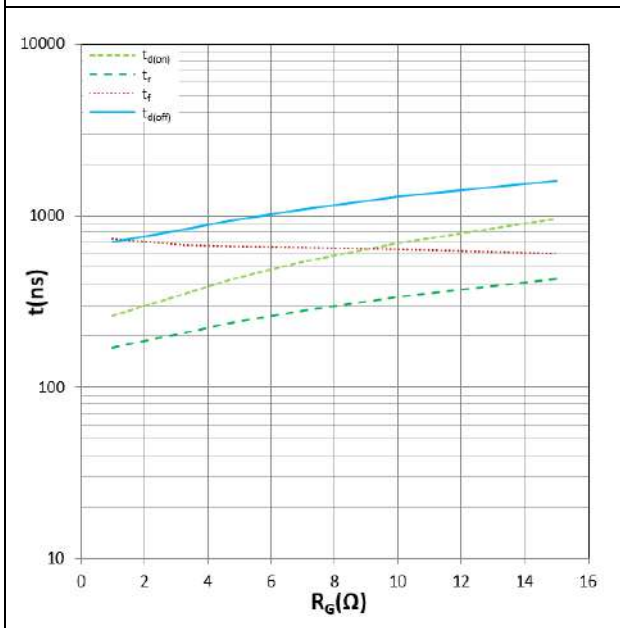

Figure 13. Switching time vs  $R_G$ (Typ)  
 $V_{CC}=900V$ ,  $V_{GE}=+15V/-8V$ ,  $I_C=300A$ ,  
 $T_j=150^\circ C$ , Inductive Load

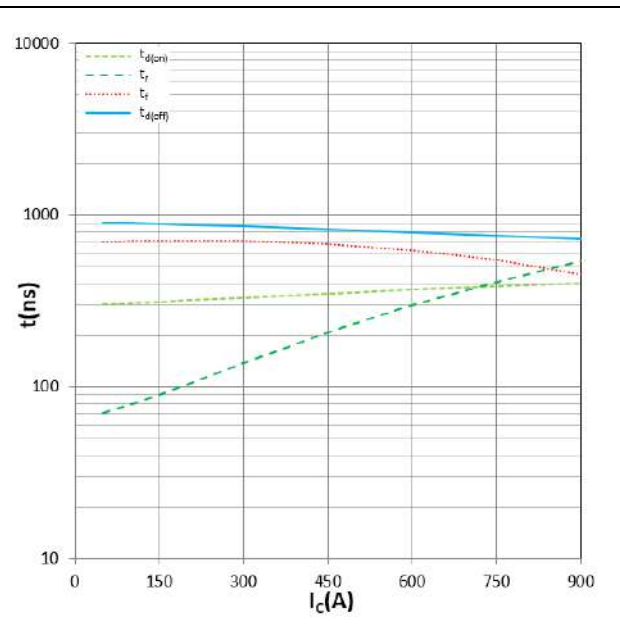
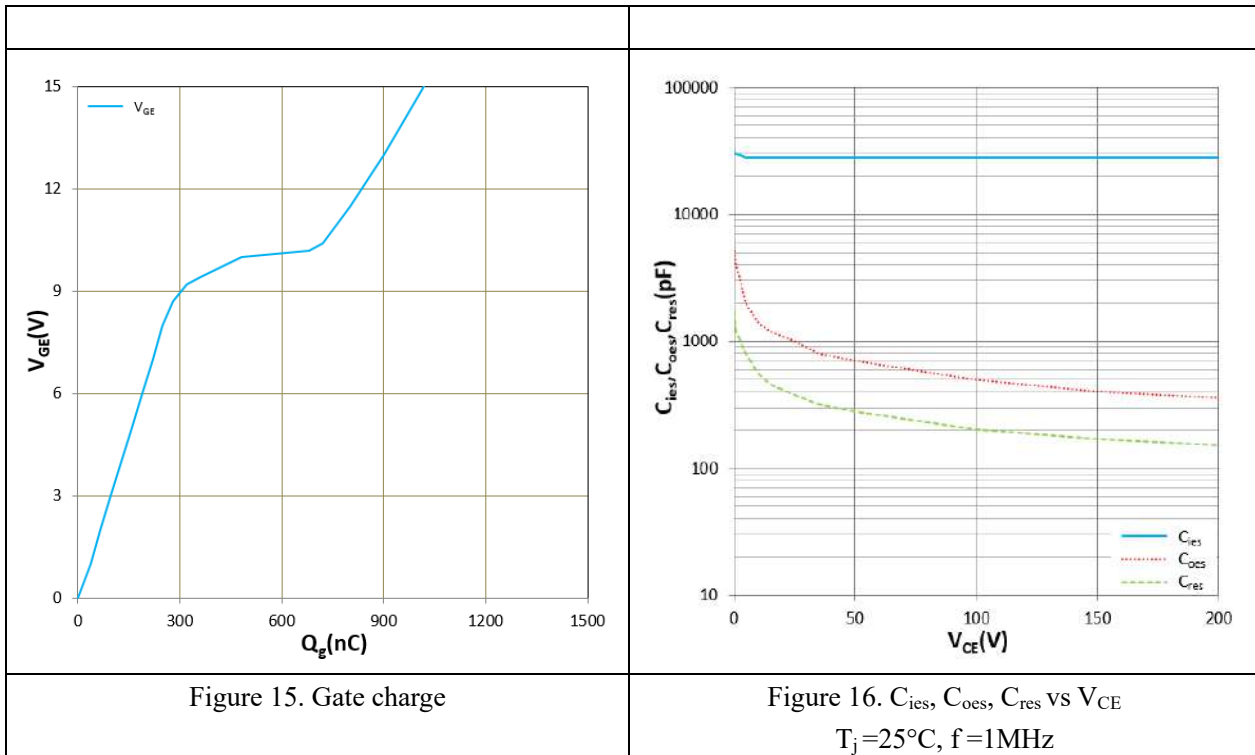

Figure 14. Switching time vs  $I_C$ (Typ)  
 $V_{CC}=900V$ ,  $V_{GE}=+15V/-8V$ ,  $R_G=3.3\Omega$   
 $T_j=150^\circ C$ , Inductive Load



## HCG300FH170D3RE1

### 1700V/300A Half Bridge IGBT Module



### IMPORTANT NOTICE:

This product data sheet describes the characteristics of this product for which a warranty is granted. Any such warranty is granted exclusively under the terms and conditions of the supply agreement. There will be no guarantee or of any kind for the product and its characteristics.

The data contained in this document is exclusively intended for technically trained staff. You and your technical departments will have to evaluate the product's suitability for the intended application and the completeness of the product data concerning such application.

Due to technical requirements, our product may contain dangerous substances. For information on the types in question, please contact the sales staff responsible for you.

Changes to this product data sheet are reserved.

### Revision History

Document Version	Description of Changes
RevX.0.1	Released

Zhejiang HIITIO New Energy Co., Ltd

ADD : NO.1125 Zhixing Road,Qiaonan District, Xiaoshan Economic and Technological Development Zone, Hangzhou, Zhejiang

TEL :400-667-9977

