

HCG450FH120D3ME7

1200V/450A Half Bridge IGBT Module

Description

The HCG450FH120D3ME7 is a Half Bridge IGBT Power Module. It integrates high performance IGBT chips designed for the applications such as High Power supply and Motor control.



Features

- Blocking voltage:1200V
- Low saturation voltage $V_{CE(sat)}$
- Low Switching Losses
- Thermistor inside

Applications

- High Power Switching Applications
- Motor Drives
- Solar inverter Systems
- Uninterrupted Power Supply

Circuit diagram

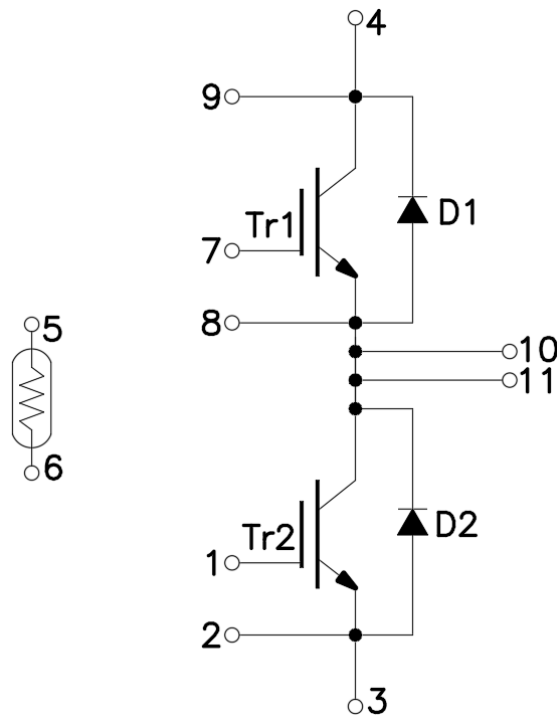


Figure 1. Out drawing & circuit diagram for HCG450FH120D3ME7

HCG450FH120D3ME7 Pin Configuration and Marking Information

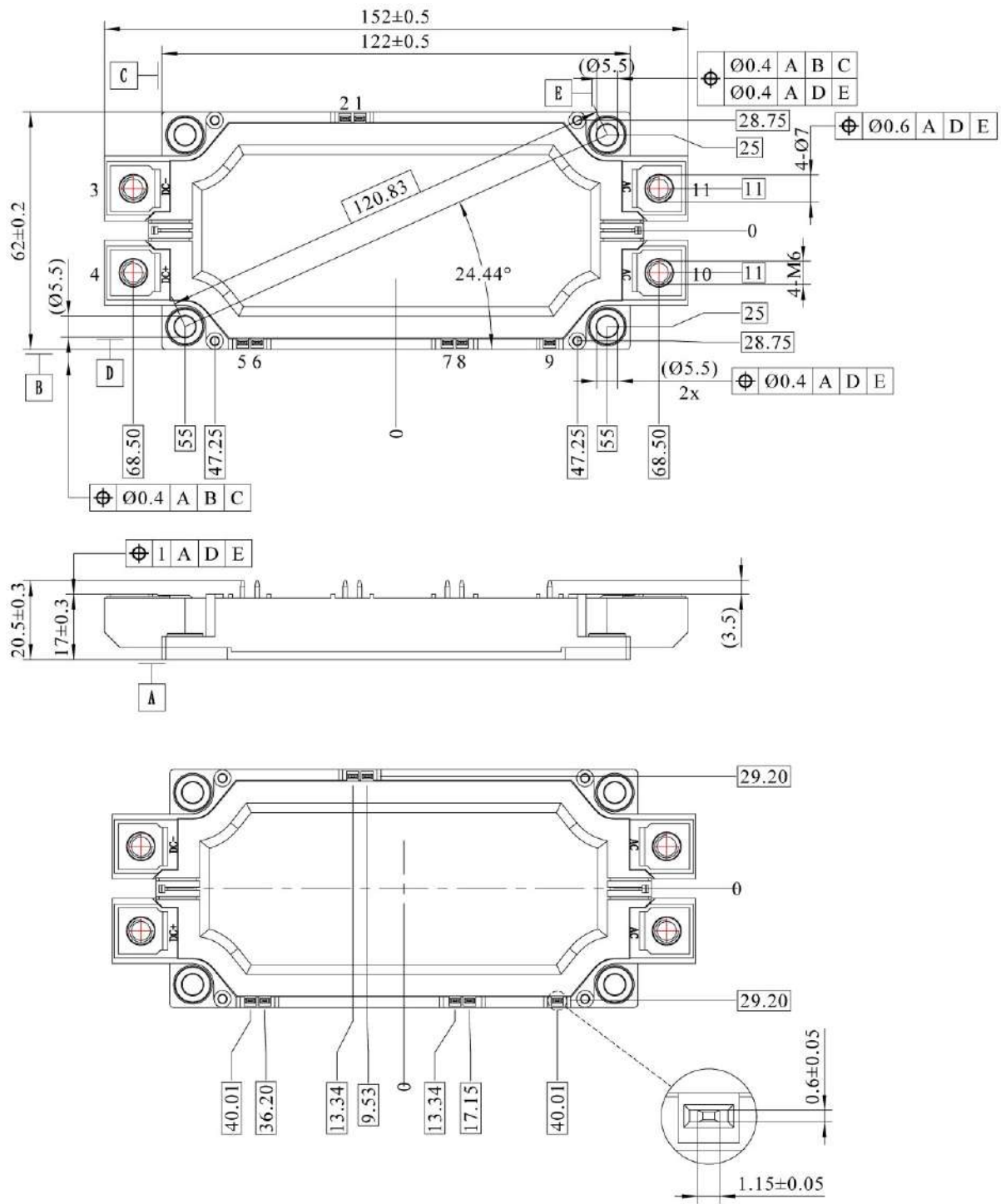


Figure 2. Pin configuration

HCG450FH120D3ME7

1200V/450A Half Bridge IGBT Module

Module

Parameter	Condition	Value	Unit
Isolation Voltage	RMS, f = 50Hz, t = 1min	3.4	kV
Material of module baseplate	-	Cu	-
Creepage distance	terminal to heatsink terminal to terminal	14.5 13	mm
Clearance	terminal to heatsink terminal to terminal	12.5 10	mm
CTI	-	600	-
Module lead resistance, terminals – chip	T _C = 25°C	0.8	mΩ
Mounting torque for module mounting	M5, M6	3 to 6	Nm
Weight	-	350	g

Maximum Ratings (T_j = 25°C unless otherwise specified)

Symbol	Parameter	Condition	Ratings	Unit
V _{CES}	Collector-Emitter Voltage	G-E Short	1200	V
V _{GES}	Gate-Emitter Voltage	C-E Short	±20	V
I _C	DC Continuous Collector Current	T _C = 95°C	450	A
I _{CM}	Pulse Collector Current	t _p = 1ms, Note1	900	A
P _C	Maximum Power Dissipation	T _C = 25°C, IGBT	2239	W
I _F	Diode Forward Current	-	450	A
I _{FRM}	Repetitive peak forward Current	t _p = 1ms, Note1	900	A
T _{vjop}	Operating junction temperature	Note2	-40 to 175	°C
T _{stg}	Storage temperature	-	-40 to 125	°C

Note1: Pulse width limited by maximum junction temperature

Note2: T_{vjop} > 150°C is only allowed for operation at overload conditions

NTC characteristics

Symbol	Parameter	Condition	Value			Unit
			Min.	Typ.	Max.	
R ₂₅	Resistance	T _C = 25°C	-	5	-	kΩ
R/R	Deviation of R ₁₀₀	T _C = 100°C, R ₁₀₀ = 493 Ω	-5	-	5	%
P ₂₅	Power dissipation	T _C = 25°C	-	-	20	mW
B _{25/50}	B-value	R ₂ = R ₂₅ exp [B _{25/50} (1/T ₂ - 1/(298,15 K))]	-	3375	-	K
B _{25/80}	B-value	R ₂ = R ₂₅ exp [B _{25/80} (1/T ₂ - 1/(298,15 K))]	-	3411	-	K
B _{25/100}	B-value	R ₂ = R ₂₅ exp [B _{25/100} (1/T ₂ - 1/(298,15 K))]	-	3433	-	K

HCG450FH120D3ME7
1200V/450A Half Bridge IGBT Module
IGBT Electrical characteristics ($T_j=25^\circ\text{C}$ unless otherwise specified, chip)

Symbol	Item	Condition		Value			Unit	
				Min.	Typ.	Max.		
$V_{CE(sat)}$ (Chip)	Collector-Emitter Saturation Voltage	$I_C=450\text{A}$ $V_{GE}=15\text{V}$	$T_j=25^\circ\text{C}$	-	1.60	1.92	V	
			$T_j=125^\circ\text{C}$	-	1.73	-		
			$T_j=150^\circ\text{C}$	-	1.80	-		
			$T_j=175^\circ\text{C}$	-	1.85	-		
$V_{GE(th)}$	Gate-Emitter threshold Voltage	$I_C=17\text{mA}, V_{CE}=V_{GE}$		5.0	5.8	6.5	V	
Q_G	Gate charge	$V_{GE} = -15\text{V to } +15\text{V}$		-	5.2	-	μC	
R_{Gint}	Internal gate resistor	-	$T_j=25^\circ\text{C}$	-	0.7	-	Ω	
C_{ies}	Input Capacitance	$V_{CE}=25\text{V}$ $V_{GE}=0\text{V}$ $f=1\text{MHz}$	$T_j=25^\circ\text{C}$	-	64.8	-	nF	
C_{oes}	Output Capacitance			-	1.76	-	nF	
C_{res}	Reverse transfer Capacitance			-	0.50	-	nF	
I_{CES}	Collector- Emitter Cut off Current	$V_{CE}=1200\text{V}, V_{GE}=0\text{V}$		$T_j=25^\circ\text{C}$	-	-	1	mA
I_{GES}	Gate-Emitter Leakage Current	$V_{GE} = 20\text{V}, V_{CE}=0\text{V}$		$T_j=25^\circ\text{C}$	-	-	1	μA
$t_{d(on)}$	Turn-on delay time	$V_{CC}=600\text{V}$ $I_C=450\text{A}$ $V_{GE}=+15\text{V}/-8\text{V}$ $R_G=1.3\Omega$ Inductive load	$T_j=25^\circ\text{C}$	-	221	-	ns	
			$T_j=125^\circ\text{C}$	-	197	-		
			$T_j=150^\circ\text{C}$	-	196	-		
t_r	Rise time		$T_j=25^\circ\text{C}$	-	55	-	ns	
			$T_j=125^\circ\text{C}$	-	59	-		
			$T_j=150^\circ\text{C}$	-	64	-		
$t_{d(off)}$	Turn-off delay time		$T_j=25^\circ\text{C}$	-	698	-	ns	
			$T_j=125^\circ\text{C}$	-	865	-		
			$T_j=150^\circ\text{C}$	-	930	-		
t_f	Fall time		$T_j=25^\circ\text{C}$	-	143	-	ns	
			$T_j=125^\circ\text{C}$	-	271	-		
			$T_j=150^\circ\text{C}$	-	303	-		
E_{on}	Turn-on power dissipation	$T_j=25^\circ\text{C}$	-	21.10	-	mJ		
		$T_j=125^\circ\text{C}$	-	29.56	-			
		$T_j=150^\circ\text{C}$	-	39.32	-			
E_{off}	Turn-off power dissipation	$T_j=25^\circ\text{C}$	-	46.31	-	mJ		
		$T_j=125^\circ\text{C}$	-	61.32	-			
		$T_j=150^\circ\text{C}$	-	63.94	-			
$R_{th(j-c)}$	Thermal Resistance, Junction to Case (IGBT)			-	0.067	-	$^\circ\text{C}/\text{W}$	
$R_{th(c-s)}$	Thermal Resistance, Case to sink (Conductive Grease applied) , Note1			-	0.020	-	$^\circ\text{C}/\text{W}$	

 Note1: Assumes Thermal Conductivity of grease is $2.8 \text{ W/m} \cdot \text{K}$ and thickness is $50\mu\text{m}$

HCG450FH120D3ME7

1200V/450A Half Bridge IGBT Module

Freewheeling Diode Electrical characteristics ($T_j=25^\circ\text{C}$ unless otherwise specified, chip)

Symbol	Item	Condition	Value			Unit	
			Min.	Typ.	Max.		
V_F	Diode Forward Voltage	$I_F=450\text{A}, V_{GE}=0\text{V}$	$T_j=25^\circ\text{C}$	-	1.64	1.97	V
			$T_j=125^\circ\text{C}$	-	1.48	-	
			$T_j=150^\circ\text{C}$	-	1.49	-	
			$T_j=175^\circ\text{C}$	-	1.44	-	
t_{rr}	Reverse recovery time	(Switch side) $V_{CC}=600\text{V}$ $I_C=450\text{A}$	$T_j=25^\circ\text{C}$	-	0.562	-	us
			$T_j=125^\circ\text{C}$	-	0.861	-	
			$T_j=150^\circ\text{C}$	-	0.947	-	
I_{RM}	Peak reverse recovery Current	(FRD side) $V_{GE}=+15\text{V}/-8\text{V}$ $R_G=1.3\ \Omega$	$T_j=25^\circ\text{C}$	-	287	-	A
			$T_j=125^\circ\text{C}$	-	371	-	
			$T_j=150^\circ\text{C}$	-	390	-	
Q_{rr}	Recovered charge	$V_{rr}=600\text{V}$ $I_F=450\text{A}$ $V_{GE}=-8\text{V}$	$T_j=25^\circ\text{C}$	-	66.21	-	uC
			$T_j=125^\circ\text{C}$	-	121.7	-	
			$T_j=150^\circ\text{C}$	-	137.3	-	
E_{rr}	Reverse recovered energy	Inductive load switching operation	$T_j=25^\circ\text{C}$	-	31.94	-	mJ
			$T_j=125^\circ\text{C}$	-	58.24	-	
			$T_j=150^\circ\text{C}$	-	65.47	-	
$R_{th(j-c)}$	Thermal Resistance, Junction to Case (Diode)		-	0.093	-	$^\circ\text{C}/\text{W}$	
$R_{th(c-s)}$	Thermal Resistance, Case to sink (Conductive Grease applied) , Note1		-	0.025	-	$^\circ\text{C}/\text{W}$	

Note1: Assumes Thermal Conductivity of grease is $2.8\text{ W/m} \cdot \text{K}$ and thickness is $50\mu\text{m}$

Test Conditions

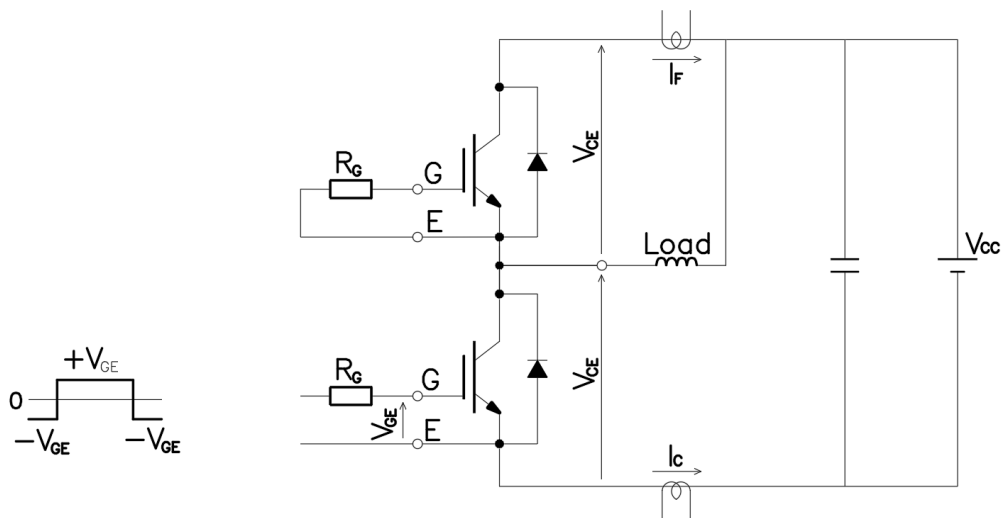


Figure 3. Switching time measure circuit

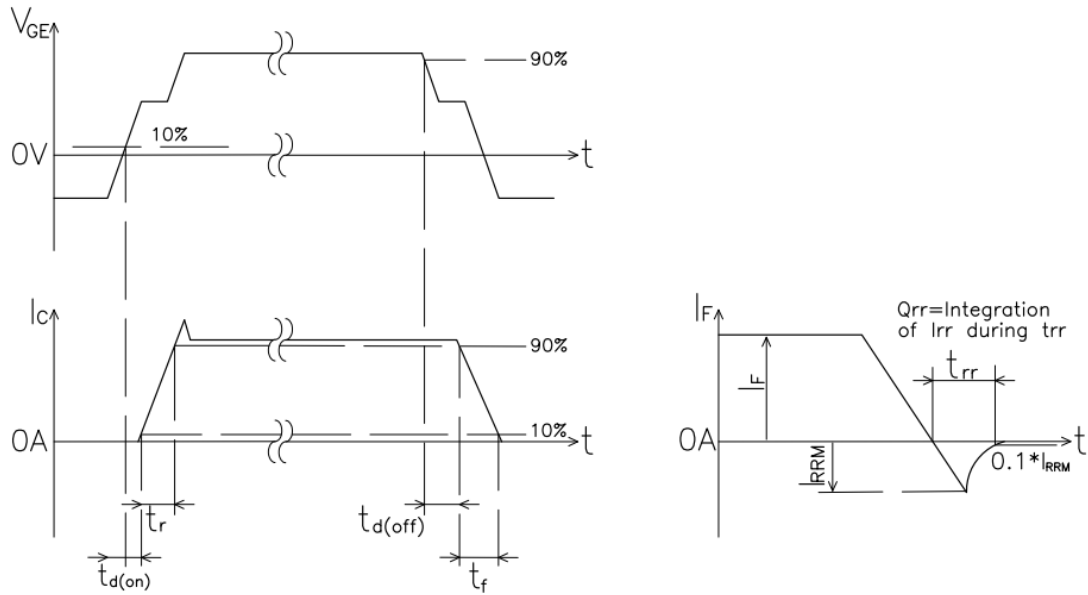
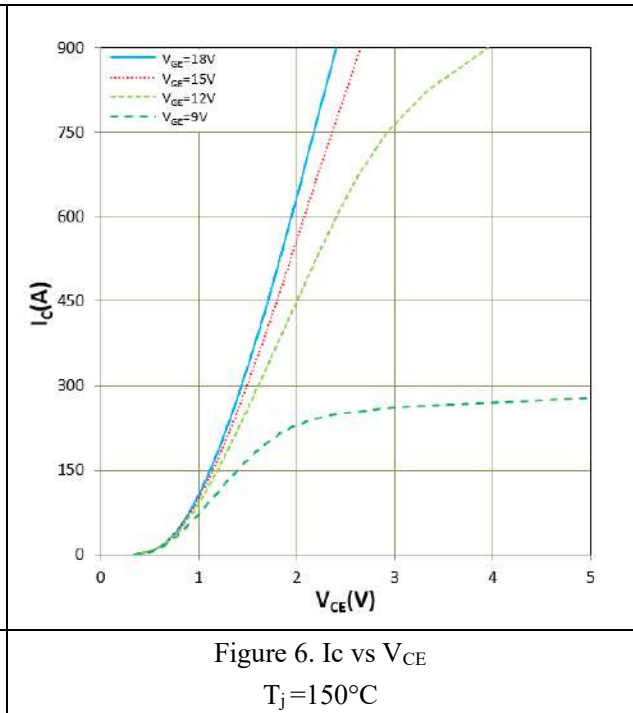
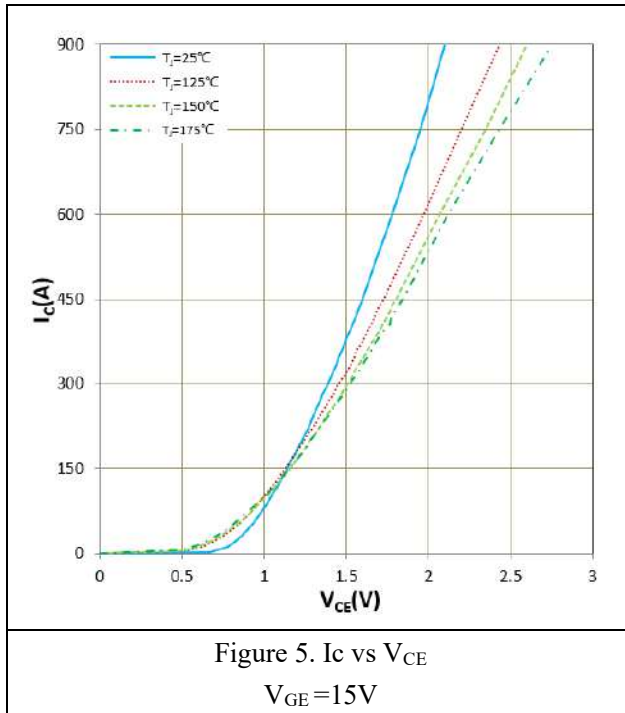
HCG450FH120D3ME7
1200V/450A Half Bridge IGBT Module


Figure 4. Switching time definition



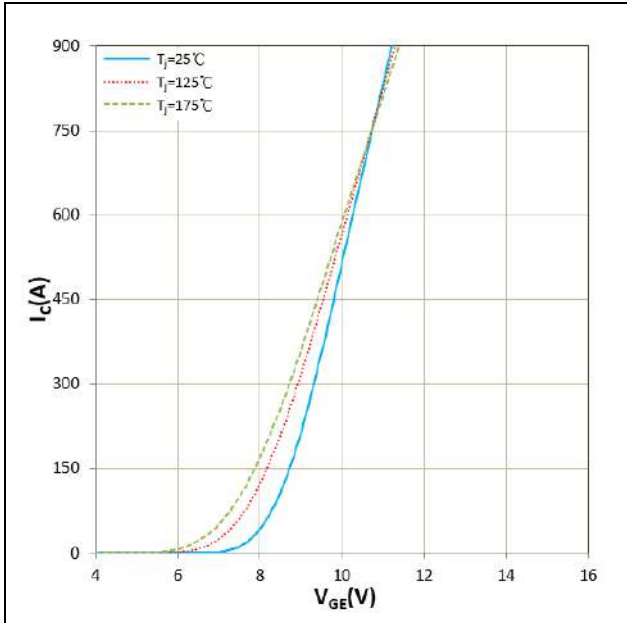
HCG450FH120D3ME7
1200V/450A Half Bridge IGBT Module


Figure 7. I_c vs V_{GE}
 $V_{CE}=20V$

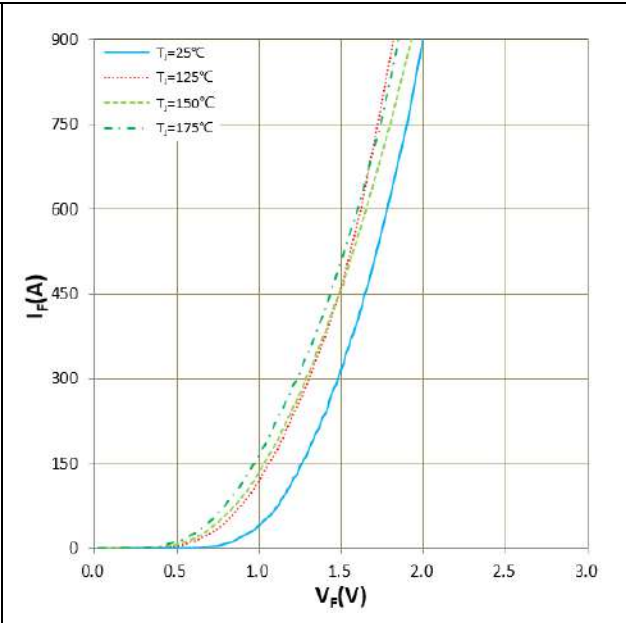


Figure 8. I_F vs V_F

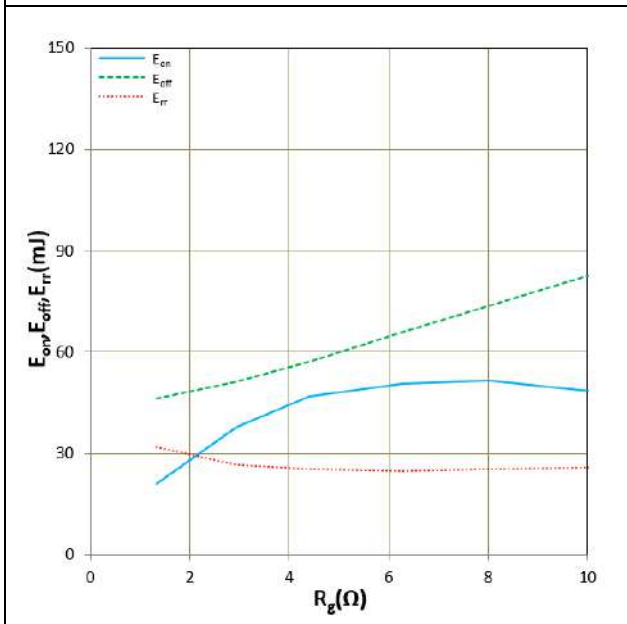


Figure 9. E_{on} , E_{off} , E_{Tr} vs R_g (Typ)
 $V_{CC}=600V$, $V_{GE}=+15V/-8V$, $I_c=450A$, $T_j=25^\circ C$
Inductive Load

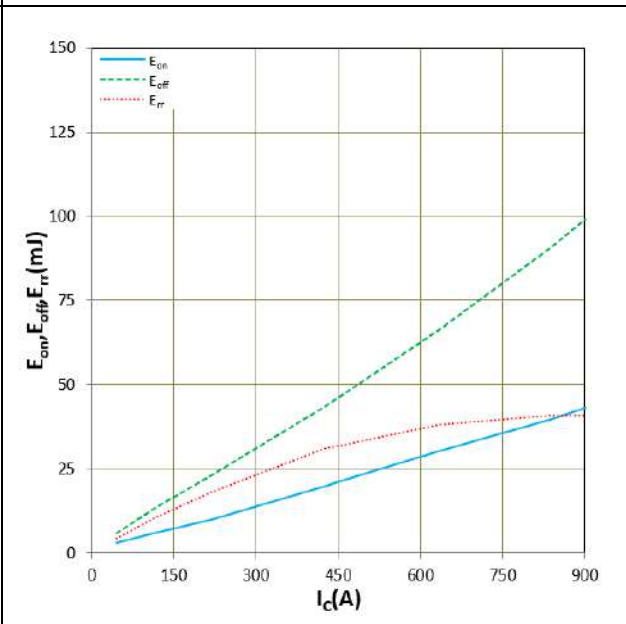


Figure 10. E_{on} , E_{off} , E_{Tr} vs I_c (Typ)
 $V_{CC}=600V$, $V_{GE}=+15V/-8V$, $R_g=1.3\Omega$, $T_j=25^\circ C$
Inductive Load

HCG450FH120D3ME7

1200V/450A Half Bridge IGBT Module

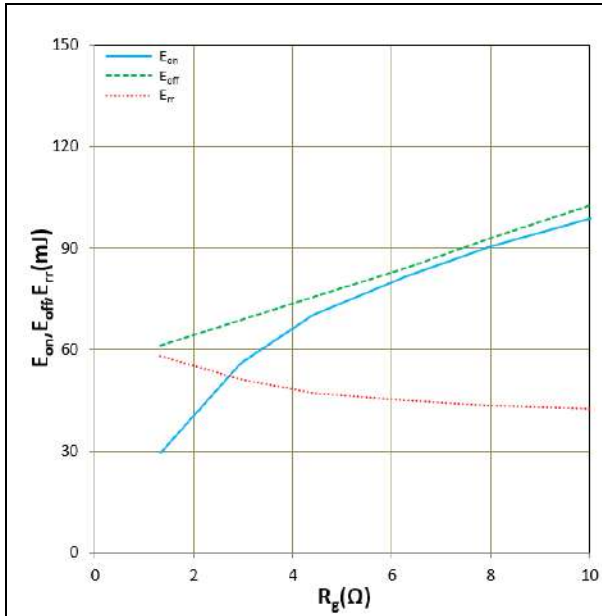


Figure 11. E_{on}, E_{off}, E_{rr} vs R_g(Typ)
 V_{CC}=600V, V_{GE}=+15V/-8V, I_C =450A, T_j =125°C
 Inductive Load

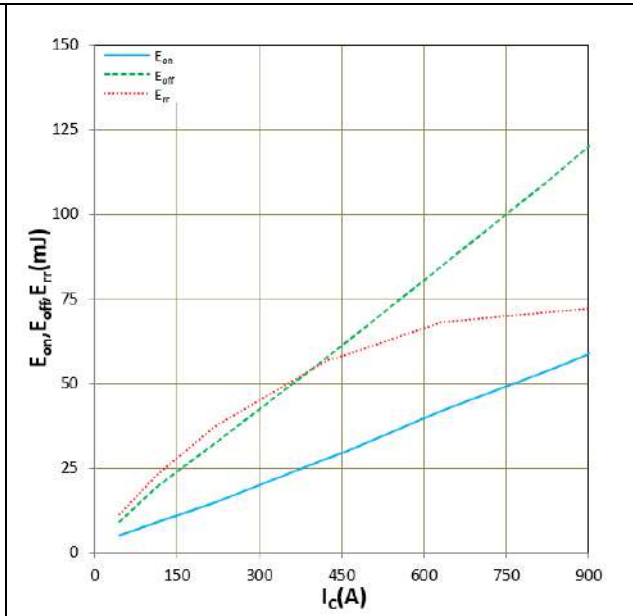


Figure 12. E_{on}, E_{off}, E_{rr} vs I_c(Typ)
 V_{CC}=600V, V_{GE}=+15V/-8V, R_g =1.3Ω, T_j =125°C
 Inductive Load

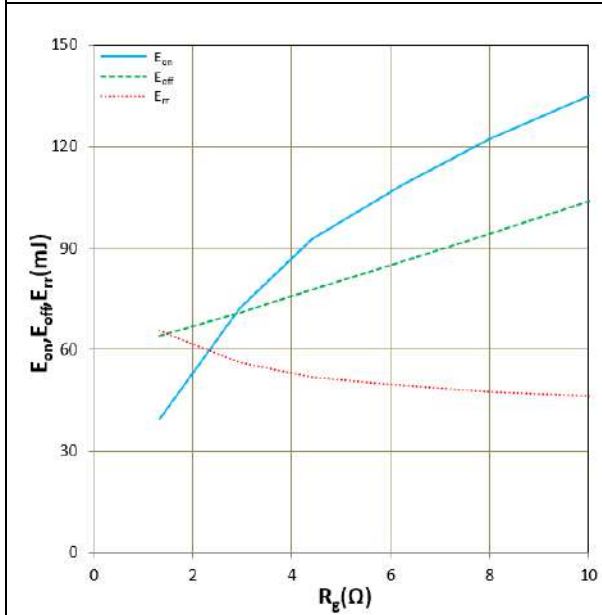


Figure 13. E_{on}, E_{off}, E_{rr} vs R_g(Typ)
 V_{CC}=600V, V_{GE}=+15V/-8V, I_C =450A, T_j =150°C
 Inductive Load

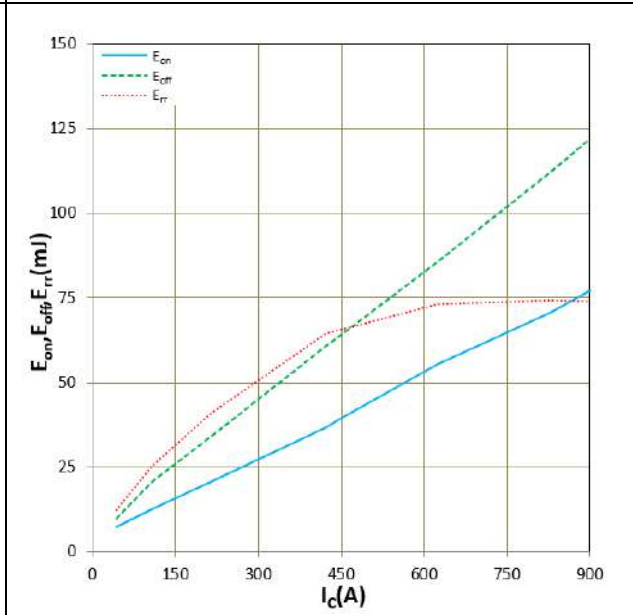


Figure 14. E_{on}, E_{off}, E_{rr} vs I_c(Typ)
 V_{CC}=600V, V_{GE}=+15V/-8V, R_g =1.3Ω, T_j =150°C
 Inductive Load

HCG450FH120D3ME7

1200V/450A Half Bridge IGBT Module

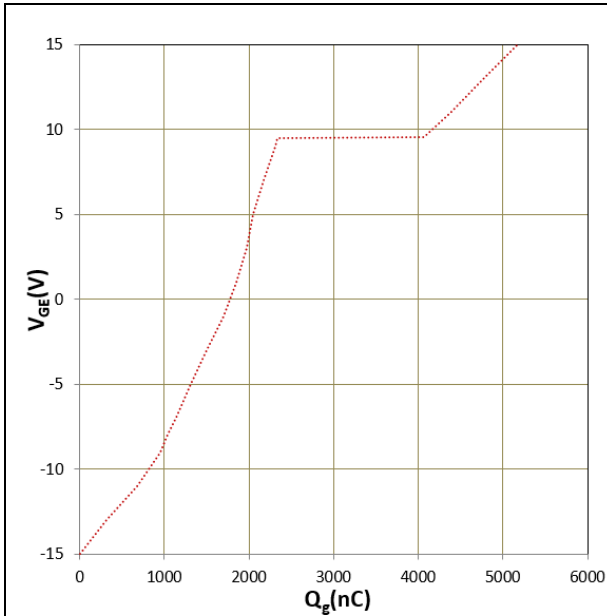


Figure 15. Gate charge

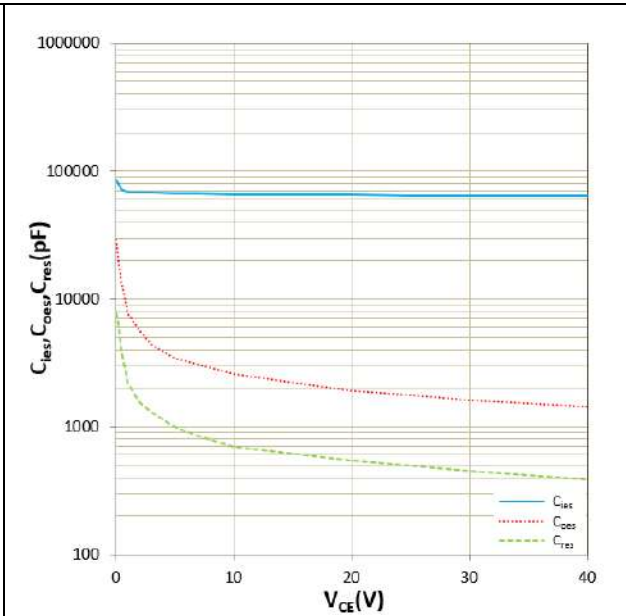


Figure 16. C_{ies} , C_{oes} , C_{res} vs V_{CE}
 $T_j = 25^\circ\text{C}$, $f = 1\text{MHz}$

IMPORTANT NOTICE:

This product data sheet describes the characteristics of this product for which a warranty is granted. Any such warranty is granted exclusively under the terms and conditions of the supply agreement. There will be no guarantee or of any kind for the product and its characteristics.

The data contained in this document is exclusively intended for technically trained staff. You and your technical departments will have to evaluate the product's suitability for the intended application and the completeness of the product data concerning such application.

Due to technical requirements, our product may contain dangerous substances. For information on the types in question, please contact the sales staff responsible for you.

Changes to this product data sheet are reserved.

Please contact the sales staff (sales@hiitio.com) for further information on the product, technology, delivery terms, conditions and prices.

Revision History

Document Version	Description of Changes
RevX.0.1	Released

Zhejiang HIITIO New Energy Co., Ltd

ADD : NO.1125 Zhixing Road,Qiaonan District, Xiaoshan Economic and
Technological Development Zone, Hangzhou, Zhejiang

TEL :400-667-9977

