

**HCG600FL100E3F1**

1000V / 600A E3 (size similar to Easy 3 with Cu Baseplate)

**Features**

- Neutral Point Clamped Three-Level Inverter Module
- Low Inductive Layout
- Solderable Pins

**Benefits**

- Higher System Efficiency
- Reduced Cooling Requirements
- Low Conduction Losses Over Temperature

**Applications**

- Solar Inverters
- Uninterruptable Power Supplies Systems

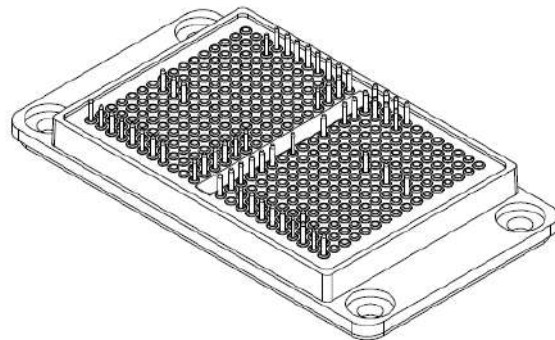

**HCG600FL100E3F1**

1000V / 600A E3 (size similar to Easy 3 with Cu Baseplate)

**Table 1 Absolute Maximum Ratings (Ta = 25 °C)**

Parameter	Symbol	Value	Unit
<b>IGBT (Q1, Q4)</b>			
Collector-Emitter Voltage	V <sub>CES</sub>	1000	V
Gate-Emitter Voltage	V <sub>GE</sub>	±23	V
Continuous Collector Current @ T <sub>c</sub> = 75°C, T <sub>j</sub> = 150°C	I <sub>c</sub>	350	A
Pulsed Collector Current @ T <sub>j</sub> = 150°C	I <sub>CP</sub>	700	A
Junction Temperature	T <sub>j</sub>	-40 to +175	°C
<b>IGBT (Q2, Q3)</b>			
Collector-Emitter Voltage	V <sub>CES</sub>	1000	V
Gate-Emitter Voltage	V <sub>GE</sub>	±23	V
Continuous Collector Current @ T <sub>c</sub> = 75°C, T <sub>j</sub> = 150°C	I <sub>c</sub>	350	A
Pulsed Collector Current @ T <sub>j</sub> = 150°C	I <sub>CP</sub>	700	A
Junction Temperature	T <sub>j</sub>	-40 to +175	°C
<b>DIODE (D1,D2,D3,D4)</b>			
Peak Repetitive Reverse Voltage	V <sub>R<sub>RRM</sub></sub>	1000	V
Continuous Forward Current @ T <sub>c</sub> = 75°C, T <sub>j</sub> = 150°C	I <sub>F</sub>	131	A
Repetitive Peak Forward Current @ T <sub>j</sub> = 150°C	I <sub>FRM</sub>	262	A
Junction Temperature	T <sub>j</sub>	-40 to +175	°C
<b>DIODE (D5,D6)</b>			
Peak Repetitive Reverse Voltage	V <sub>R<sub>RRM</sub></sub>	1000	V
Continuous Forward Current @ T <sub>c</sub> = 75°C, T <sub>j</sub> = 150°C	I <sub>F</sub>	131	A
Repetitive Peak Forward Current @ T <sub>j</sub> = 150°C	I <sub>FRM</sub>	262	A
Junction Temperature	T <sub>j</sub>	-40 to +175	°C
<b>INSULATION PROPERTIES</b>			
Isolation Test Voltage, t = 1 s, 50 Hz	V <sub>iso</sub>	4000	V <sub>RMS</sub>
<b>RECOMMENDED TEMPERATURE</b>			
Storage Temperature	T <sub>stg</sub>	-40 to +125	°C
Operating Temperature	T <sub>vjop</sub>	-40 to +150	°C

**HCG600FL100E3F1**

1000V / 600A E3 (size similar to Easy 3 with Cu Baseplate)

**Table 2 Characteristics Values**

Parameter	Symbol	Conditions	Min.	Typ.	Max.	Unit	
<b>IGBT (Q1, Q4)</b>							
Collector-Emitter Saturation Voltage	$V_{CE(sat)}$	$V_{GE} = 15\text{ V}$ , $I_C = 600\text{ A}$	$T_j = 25^\circ\text{C}$	-	1.56	-	V
		$V_{GE} = 15\text{ V}$ , $I_C = 600\text{ A}$	$T_j = 150^\circ\text{C}$	-	1.88	-	
Gate-Emitter Threshold Voltage	$V_{GE(TH)}$	$V_{GE} = V_{CE}$ , $I_C = 9\text{ mA}$	$T_j = 25^\circ\text{C}$	-	3.87	-	V
Total Gate Charge	$Q_g$	$V_{GE} = \pm 15\text{ V}$ , $V_{CE} = 600\text{ V}$	$T_j = 25^\circ\text{C}$	-	1.93	-	$\mu\text{C}$
Gate-Source Leakage Current	$I_{GES}$	$V_{GE} = 20\text{ V}$ , $V_{CE} = 0\text{ V}$	$T_j = 25^\circ\text{C}$	-	-	1	$\mu\text{A}$
Collector-Emitter Voltage	$V_{(BR)CES}$	$V_{GE} = 0\text{ V}$	$T_j = 25^\circ\text{C}$	1000	-	-	V
Collector-Emitter Cutoff Current	$I_{CES}$	$V_{CE} = 1000\text{ V}$ , $V_{GE} = 0\text{ V}$	$T_j = 25^\circ\text{C}$	-	-	100	$\mu\text{A}$
Input Capacitance	$C_{iss}$	$V_{GE} = 0\text{ V}$ , $V_{CE} = 20\text{ V}$ , $f = 100\text{ KHz}$	$T_j = 25^\circ\text{C}$	-	28.7	-	nF
Output Capacitance	$C_{oss}$		$T_j = 25^\circ\text{C}$	-	1.70	-	
Reverse Transfer Capacitance	$C_{riss}$		$T_j = 25^\circ\text{C}$	-	0.27	-	
Turn-on Delay Time(inductive load)	$t_{don}$	$V_{GE} = -7\text{ V} / +15\text{ V}$ , $V_{CE} = 675\text{ V}$ , $I_C = 330\text{ A}$ , $R_{Gon} = 0.5\ \Omega$ , $R_{Goff} = 5.1\ \Omega$	$T_j = 25^\circ\text{C}$	-	100	-	ns
Rise Time (inductive load)	$t_r$		$T_j = 150^\circ\text{C}$	-	105	-	
			$T_j = 25^\circ\text{C}$	-	20	-	
Turn-off Delay Time(inductive load)	$t_{doff}$		$T_j = 150^\circ\text{C}$	-	25	-	
			$T_j = 25^\circ\text{C}$	-	1100	-	
Fall Time (inductive load)	$t_f$		$T_j = 150^\circ\text{C}$	-	1200	-	
			$T_j = 25^\circ\text{C}$	-	30	-	
Turn-on Switching Loss	$E_{on}$		$T_j = 150^\circ\text{C}$	-	35	-	
			$T_j = 25^\circ\text{C}$	-	10.7	-	
Turn-off Switching Loss	$E_{off}$		$T_j = 150^\circ\text{C}$	-	16.66	-	
		$T_j = 25^\circ\text{C}$	-	8.5	-		
Thermal Resistance – Chip-to-Case	$R_{thJC}$	Thermal grease, $\lambda = 2.8\text{ W/mK}$	$T_j = 150^\circ\text{C}$	-	14.01	-	$^\circ\text{C/W}$
			$T_j = 25^\circ\text{C}$	-	0.099	-	

**HCG600FL100E3F1**

1000V / 600A E3 (size similar to Easy 3 with Cu Baseplate)

Parameter	Symbol	Conditions	Min.	Typ.	Max.	Unit	
<b>DIODE (D5,D6)</b>							
Diode Forward Voltage	$V_F$	$I_F = 300\text{ A}$	$T_j = 25^\circ\text{C}$	-	2.26	-	V
		$I_F = 300\text{ A}$	$T_j = 150^\circ\text{C}$	-	2.30	-	
Reverse Recovery Time	$T_{RR}$	$V_{GE} = -7\text{ V} / +15\text{ V}$ , $V_{CE} = 675\text{ V}$ , $I_C = 330\text{ A}$ , $R_{Gon} = 0.5\ \Omega$ , $R_{Goff} = 5.1\ \Omega$	$T_j = 25^\circ\text{C}$	-	95	-	ns
			$T_j = 150^\circ\text{C}$	-	200	-	
Reverse Recovery Charge	$Q_{RR}$		$T_j = 25^\circ\text{C}$	-	14.5	-	$\mu\text{C}$
			$T_j = 150^\circ\text{C}$	-	35.3	-	
Peak Reverse Recovery Current	$I_{RRM}$		$T_j = 25^\circ\text{C}$	-	300	-	A
			$T_j = 150^\circ\text{C}$	-	450	-	
Reverse Recovery Energy	$E_{REC}$		$T_j = 25^\circ\text{C}$	-	5.25	-	mJ
			$T_j = 150^\circ\text{C}$	-	11.75	-	
Thermal Resistance - Chip-to-Case	$R_{thJC}$		Thermal grease $\lambda = 2.8\text{ W/mK}$	-	0.243	-	$^\circ\text{C/W}$
<b>IGBT (Q2, Q3)</b>							
Collector-Emitter Saturation Voltage	$V_{CE(sat)}$	$V_{GE} = 15\text{ V}$ , $I_C = 600\text{ A}$	$T_j = 25^\circ\text{C}$	-	1.56	-	V
		$V_{GE} = 15\text{ V}$ , $I_C = 600\text{ A}$	$T_j = 150^\circ\text{C}$	-	1.88	-	
Gate-Emitter Threshold Voltage	$V_{GE(TH)}$	$V_{GE} = V_{CE}$ , $I_C = 9\text{ mA}$	$T_j = 25^\circ\text{C}$	-	3.87	-	V
Total Gate Charge	$Q_g$	$V_{GE} = \pm 15\text{ V}$ , $V_{CE} = 600\text{ V}$	$T_j = 25^\circ\text{C}$	-	1.93	-	$\mu\text{C}$
Gate-Source Leakage Current	$I_{GES}$	$V_{GE} = 20\text{ V}$ , $V_{CE} = 0\text{ V}$	$T_j = 25^\circ\text{C}$	-	-	100	nA
Collector-Emitter Voltage	$V_{(BR)CES}$	$V_{GE} = 0\text{ V}$	$T_j = 25^\circ\text{C}$	1000	-	-	V
Collector-Emitter Cutoff Current	$I_{CES}$	$V_{CE} = 1000\text{ V}$ , $V_{GE} = 0\text{ V}$	$T_j = 25^\circ\text{C}$	-	-	100	$\mu\text{A}$
Input Capacitance	$C_{iss}$	$V_{GE} = 0\text{ V}$ , $V_{CE} = 20\text{ V}$ , $f = 100\text{ KHz}$	$T_j = 25^\circ\text{C}$	-	28.7	-	nF
Output Capacitance	$C_{oss}$		$T_j = 25^\circ\text{C}$	-	1.70	-	
Reverse Transfer Capacitance	$C_{rSS}$		$T_j = 25^\circ\text{C}$	-	0.27	-	
Turn-on Delay Time(inductive load)	$t_{don}$	$V_{GE} = -7\text{ V} / +15\text{ V}$ , $V_{CE} = 675\text{ V}$ , $I_C = 330\text{ A}$ , $R_{Gon} = 0.51\ \Omega$ , $R_{Goff} = 5.1\ \Omega$	$T_j = 25^\circ\text{C}$	-	90	-	ns
			$T_j = 150^\circ\text{C}$	-	100	-	
Rise Time (inductive load)	$t_r$		$T_j = 25^\circ\text{C}$	-	25	-	
			$T_j = 150^\circ\text{C}$	-	30	-	
Turn-off Delay Time(inductive load)	$t_{doff}$		$T_j = 25^\circ\text{C}$	-	1120	-	
			$T_j = 150^\circ\text{C}$	-	1250	-	

**HCG600FL100E3F1**

1000V / 600A E3 (size similar to Easy 3 with Cu Baseplate)

Parameter	Symbol	Conditions	Min.	Typ.	Max.	Unit	
Fall Time (inductive load)	$t_f$	$V_{GE} = -7\text{ V} / +15\text{ V}$ , $V_{CE} = 675\text{ V}$ , $I_c = 330\text{ A}$ , $R_{Gon} = 0.51\ \Omega$ , $R_{Goff} = 5.1\ \Omega$	$T_j = 25^\circ\text{C}$	-	28	-	ns
			$T_j = 150^\circ\text{C}$	-	37	-	
Turn-on Switching Loss	$E_{on}$	$R_{Gon} = 0.51\ \Omega$ , $R_{Goff} = 5.1\ \Omega$	$T_j = 25^\circ\text{C}$	-	9.35	-	mJ
			$T_j = 150^\circ\text{C}$	-	14.64	-	
Turn-off Switching Loss	$E_{off}$		$T_j = 25^\circ\text{C}$	-	8.37	-	
			$T_j = 150^\circ\text{C}$	-	14.75	-	
Thermal Resistance – Chip-to-Case	$R_{thJC}$	Thermal grease, $\lambda = 2.8\text{ W/mK}$	-	0.099	-	$^\circ\text{C/W}$	

**INVERSE DIODE (D1,D2,D3,D4)**

Parameter	Symbol	Conditions	Min.	Typ.	Max.	Unit	
Diode Forward Voltage	$V_F$	$I_F = 300\text{ A}$	$T_j = 25^\circ\text{C}$	-	2.27	-	V
			$T_j = 150^\circ\text{C}$	-	2.30	-	
Reverse Recovery Time	$T_{RR}$	$V_{GE} = -7\text{ V} / +15\text{ V}$ , $V_{CE} = 675\text{ V}$ , $I_c = 330\text{ A}$ , $R_{Gon} = 0.51\ \Omega$ , $R_{Goff} = 5.1\ \Omega$	$T_j = 25^\circ\text{C}$	-	100	-	ns
			$T_j = 150^\circ\text{C}$	-	200	-	
Reverse Recovery Charge	$Q_{RR}$	$R_{Gon} = 0.51\ \Omega$ , $R_{Goff} = 5.1\ \Omega$	$T_j = 25^\circ\text{C}$	-	15	-	$\mu\text{C}$
			$T_j = 150^\circ\text{C}$	-	36	-	
Peak Reverse Recovery Current	$I_{RRM}$		$T_j = 25^\circ\text{C}$	-	280	-	A
			$T_j = 150^\circ\text{C}$	-	350	-	
Reverse Recovery Energy	$E_{REC}$		$T_j = 25^\circ\text{C}$	-	5.27	-	mJ
			$T_j = 150^\circ\text{C}$	-	11.01	-	
Thermal Resistance – Chip-to-Case	$R_{thJC}$	Thermal grease, $\lambda = 2.8\text{ W/mK}$	-	0.243	-	$^\circ\text{C/W}$	

**HCG600FL100E3F1**

1000V / 600A E3 (size similar to Easy 3 with Cu Baseplate)

**Table 3 NTC-Thermistor**

Parameter	Symbol	Conditions	Min	Typ.	Max	Unit
Rated Resistance	$R_{25}$	$T_C = 25^{\circ}\text{C}$	-	22	-	k $\Omega$
Deviation of R100	$\Delta R/R$	$T_C = 100^{\circ}\text{C}$ , $R_{100} = 1486 \Omega$	-5	-	5	%
Power Dissipation	P25	TNTC = 25°C	-	-	20	mW
B-value	$B_{25/50}$	B (25/50), tolerance $\pm 3\%$	-	3950	-	K
B-value	$B_{25/100}$	B (25/100), tolerance $\pm 3\%$	-	3998	-	K

**Table 4 Module Characteristics**

Parameter	Symbol	Conditions	Min	Typ.	Max	Unit
Stray Inductance	$L_{CE}$		-	15	-	nH
Mounting Torque Screw:M5	M		3.0	-	5.0	N.m
Creepage Distance		terminal to heatsink		11.5		
Clearance		terminal to heatsink		9.4		
CTI				$\geq 600$		
Flatness of base plate					0.3	mm
Weight				250		g

# HCG600FL100E3F1

1000V / 600A E3 (size similar to Easy 3 with Cu Baseplate)

## Typical Characteristics

Fig.1 Typical output characteristics IGBT  
 $I_c = f(V_{CE})$   
 $V_{GE} = 15V$  (Q1, Q2, Q3, Q4)

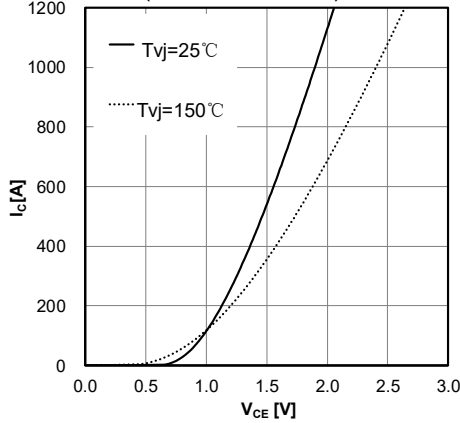

Fig.2 Typical output characteristics IGBT  
 $T_{vj} = 150^{\circ}C$  (Q1, Q2, Q3, Q4)

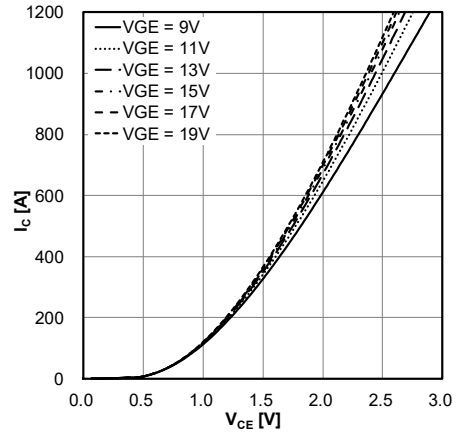

Fig.3 Body diode characteristics (D1, D2, D3, D4)

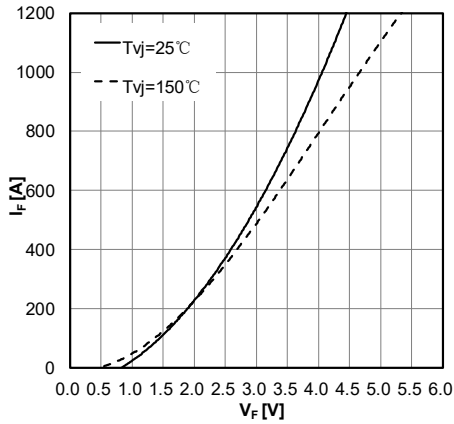

Fig.4 Transient thermal impedance (Q1, Q2, Q3, Q4)

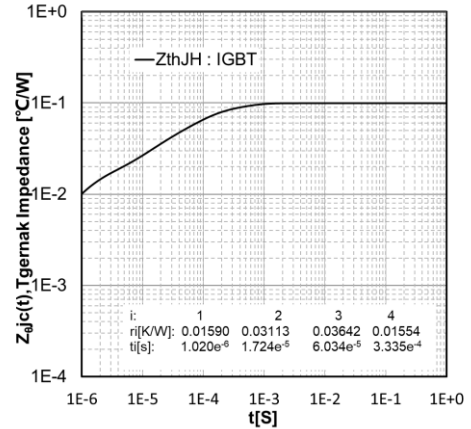

Fig.5 Capacity characteristic  
 $C = f(V_{CE})$ ,  $V_{GE} = 0V$ ,  $T_{vj} = 25^{\circ}C$ ,  $f = 100\text{ KHz}$   
(Q1, Q2, Q3, Q4)

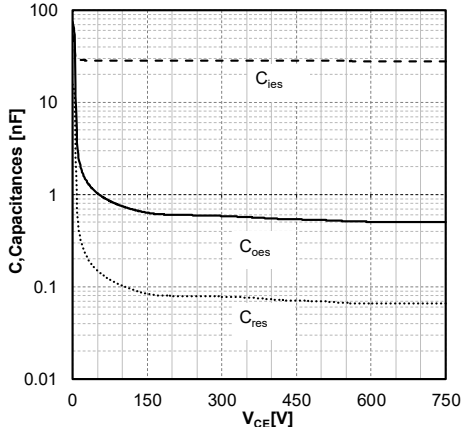
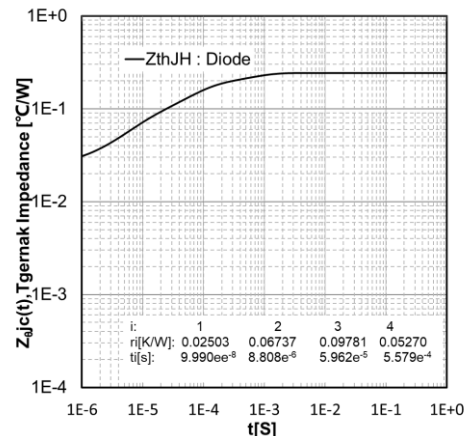

Fig.6 Transient thermal impedance (D1, D2, D3, D4)



## HCG600FL100E3F1

1000V / 600A E3 (size similar to Easy 3 with Cu Baseplate)

### Typical Characteristics

Fig.7 Diode forward characteristics (D5, D6)

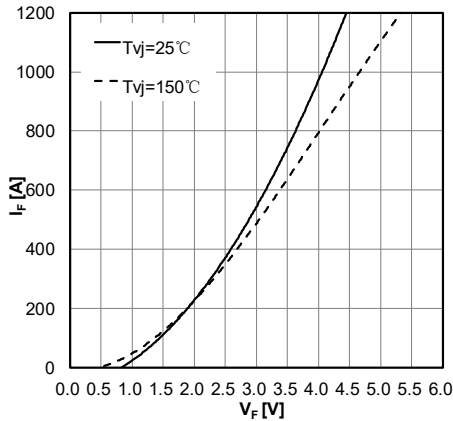
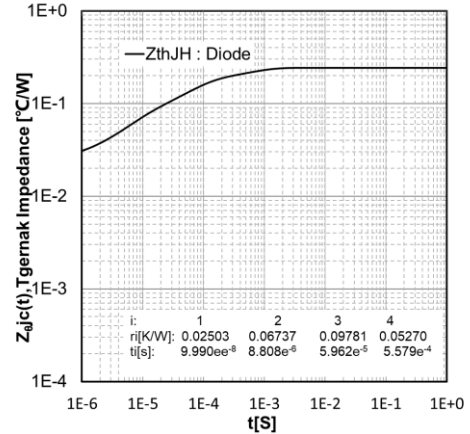

Fig.8 Transient thermal impedance (D5, D6)



#### Q1 || D5 or Q4 || D6

Fig.9 Switching losses IGBT, Inverter (typical)

$E_{on} = f(I_C)$ ,  $E_{off} = f(I_C)$ ,

$V_{GE} = +15\text{ V} / -7\text{ V}$ ,  $R_{Gon} = 0.5\ \Omega$ ,  $R_{Goff} = 5.1\ \Omega$

$V_{CE} = 675\text{ V}$

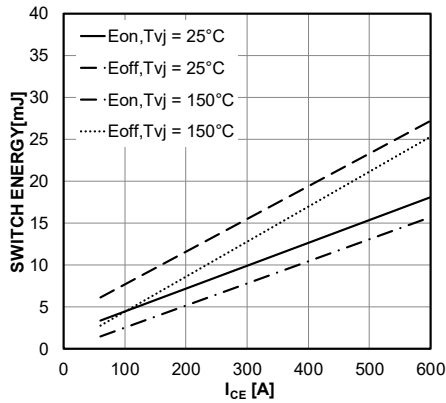

Fig.10 Switching losses IGBT, Inverter (typical)

$E_{on} = f(R_G)$ ,

$V_{GE} = +15\text{ V} / -7\text{ V}$ ,  $I_C = 330\text{ A}$ ,  $V_{CE} = 675\text{ V}$

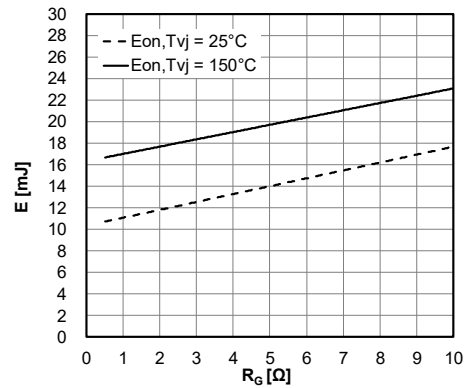

Fig.11 Switching losses IGBT, Inverter (typical)

$E_{off} = f(R_G)$ ,

$V_{GE} = +15\text{ V} / -7\text{ V}$ ,  $I_C = 330\text{ A}$ ,  $V_{CE} = 675\text{ V}$

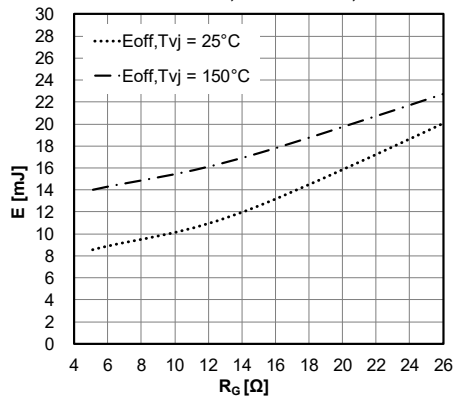
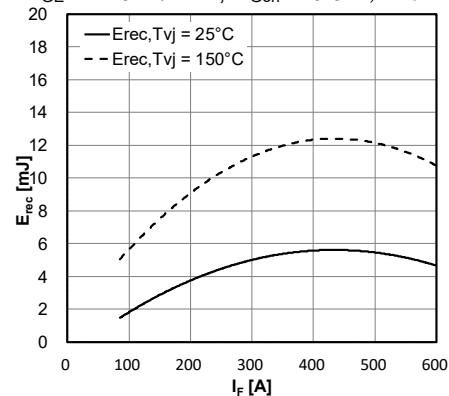

Fig.12 Switching losses IGBT, Inverter (typical)

$E_{rec} = f(I_C)$ ,

$V_{GE} = +15\text{ V} / -7\text{ V}$ ,  $R_{Gon} = 0.5\ \Omega$ ,  $V_{CE} = 675\text{ V}$





# HCG600FL100E3F1

1000V / 600A E3 (size similar to Easy 3 with Cu Baseplate)

## Typical Characteristics

Q2||D3+D4 or Q3||D1+D2

Fig.13 Switching losses IGBT, Inverter (typical)  
 $E_{on} = f(I_c)$ ,  $E_{off} = f(I_c)$ ,  
 $V_{GE} = +15\text{ V} / -7\text{ V}$ ,  $R_{Gon} = 0.51\ \Omega$ ,  $R_{Goff} = 5.1\ \Omega$ ,  
 $V_{CE} = 675\text{ V}$

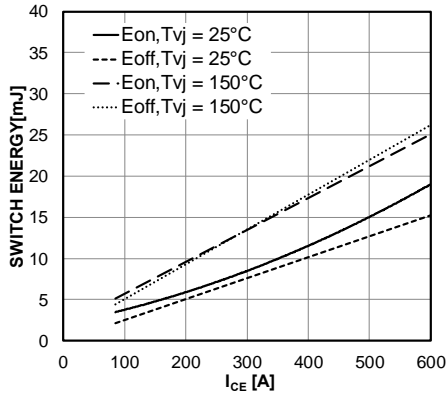

Fig.14 Switching losses IGBT, Inverter (typical)  
 $E_{on} = f(R_G)$ ,  
 $V_{GE} = +15\text{ V} / -7\text{ V}$ ,  $I_c = 330\text{ A}$ ,  $V_{CE} = 675\text{ V}$

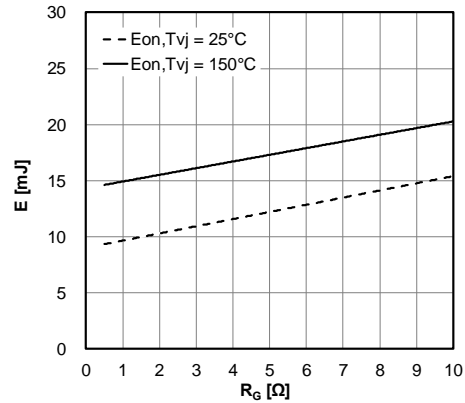

Fig.15 Switching losses IGBT, Inverter (typical)  
 $E_{off} = f(R_G)$ ,  
 $V_{GE} = +15\text{ V} / -7\text{ V}$ ,  $I_c = 330\text{ A}$ ,  $V_{CE} = 675\text{ V}$

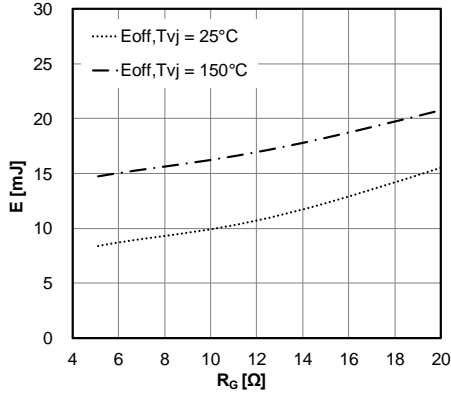

Fig.16 Switching losses IGBT, Inverter (typical)  
 $E_{rec} = f(I_c)$ ,  
 $V_{GE} = +15\text{ V} / -7\text{ V}$ ,  $R_{Gon} = 0.5\ \Omega$ ,  $V_{CE} = 675\text{ V}$

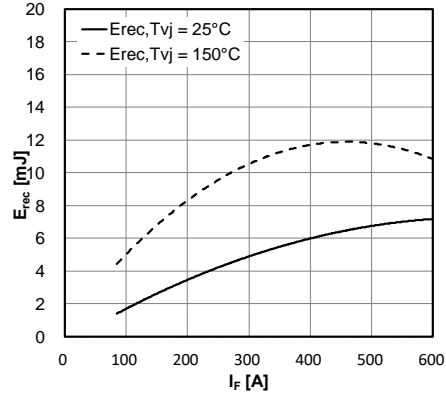

Fig.17 NTC-Thermistor-temperature characteristic (typical)

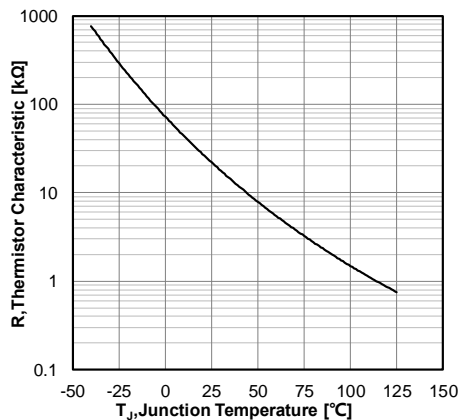
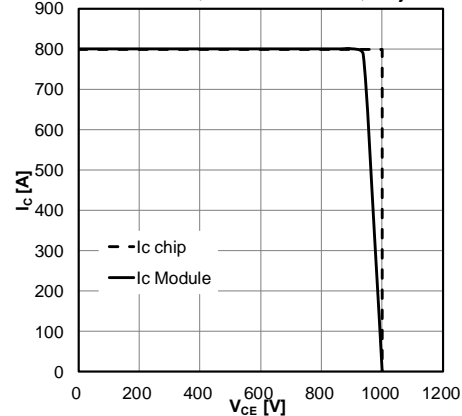

Fig.18 Reverse bias safe operating area IGBT, Inverter (RBSOA)

$I_c = f(V_{CE})$ ,  
 $V_{GE} = +15\text{ V} / -7\text{ V}$ ,  $R_{Goff} = 5.1\ \Omega$ ,  $T_{vj} = 150^{\circ}\text{C}$



**HCG600FL100E3F1**

1000V / 600A E3 (size similar to Easy 3 with Cu Baseplate)

**Circuit Diagram**

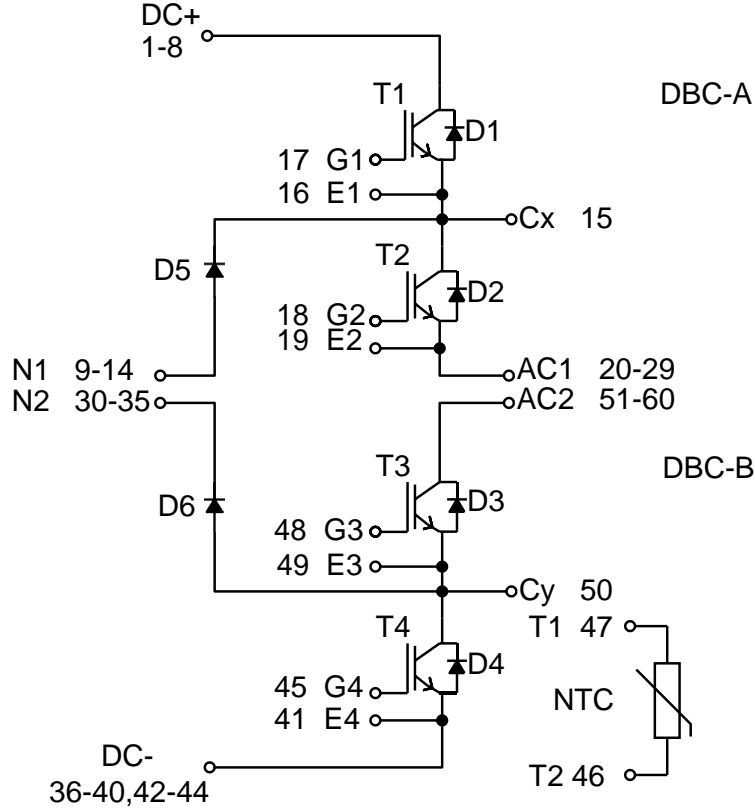

**Pin Connections**

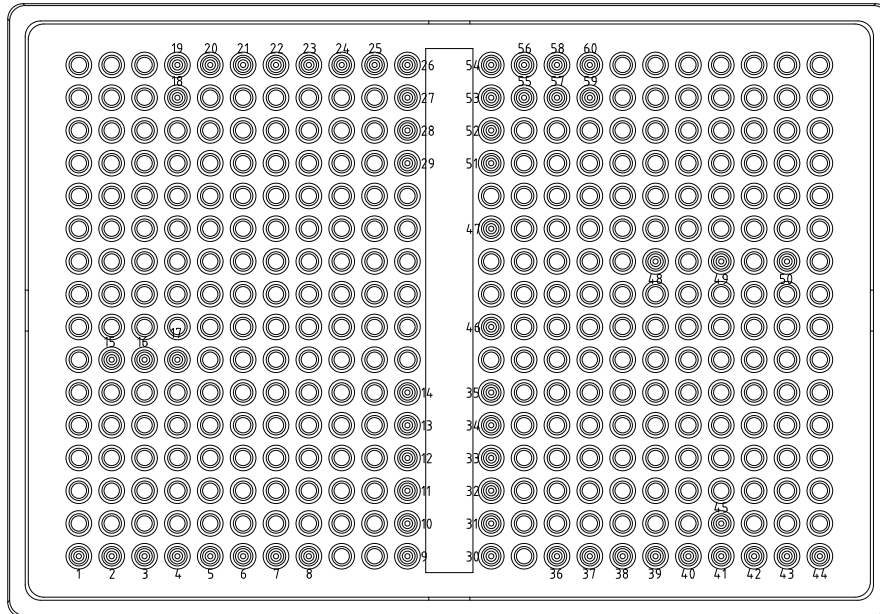

**HCG600FL100E3F1**

1000V / 600A E3 (size similar to Easy 3 with Cu Baseplate)

**Package Outlines**

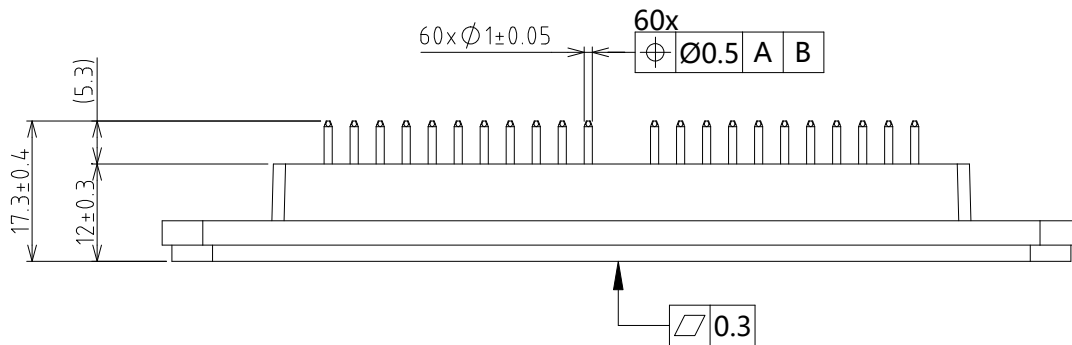
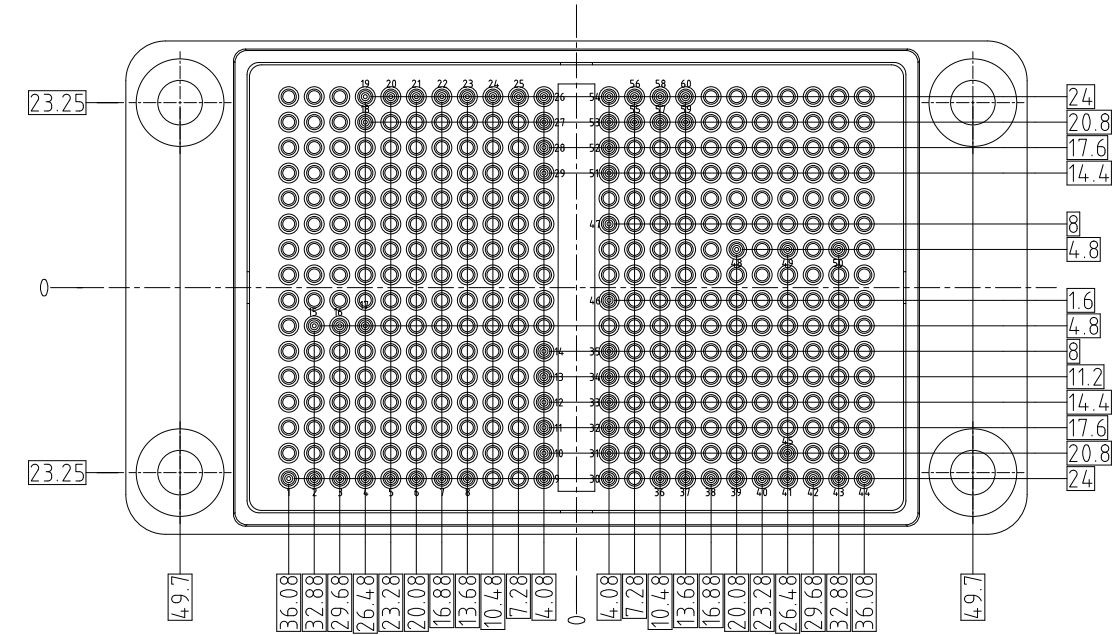

**HCG600FL100E3F1**

1000V / 600A E3 (size similar to Easy 3 with Cu Baseplate)

**Package Outlines**

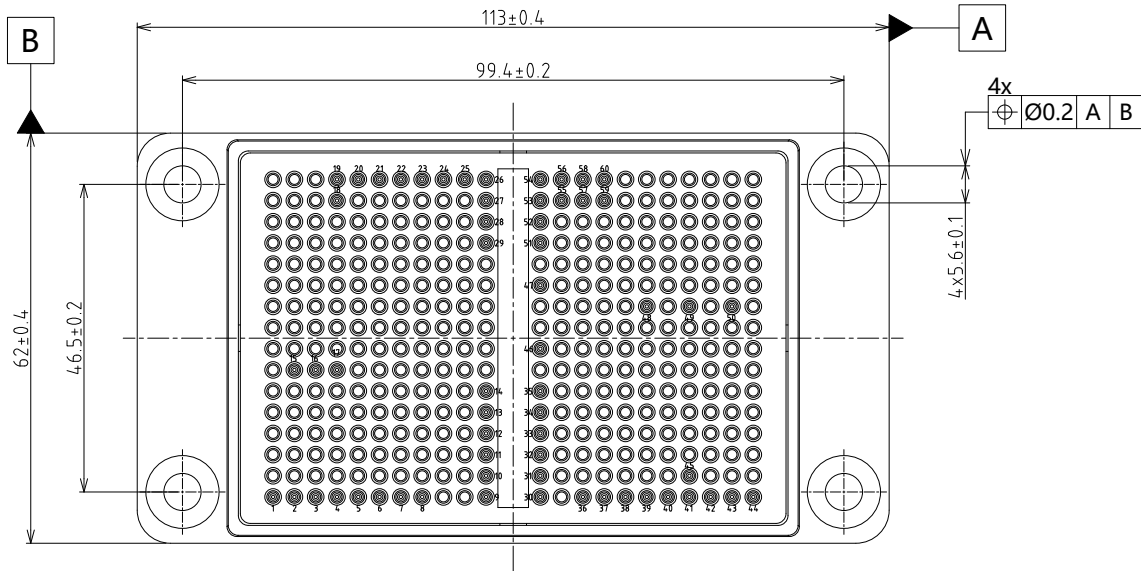

## Revision History

Document Version	Description of Changes
RevX.0.1	Released

### Zhejiang HIITIO New Energy Co., Ltd

ADD : NO.1125 Zhixing Road,Qiaonan District, Xiaoshan Economic and Technological Development Zone, Hangzhou, Zhejiang

TEL :400-667-9977



#### IMPORTANT NOTICE:

This product data sheet describes the characteristics of this product for which a warranty is granted. Any such warranty is granted exclusively under the terms and conditions of the supply agreement. There will be no guarantee or of any kind for the product and its characteristics.

The data contained in this document is exclusively intended for technically trained staff. You and your technical departments will have to evaluate the product's suitability for the intended application and the completeness of the product data concerning such application.

Due to technical requirements, our product may contain dangerous substances. For information on the types in question, please contact the sales staff responsible for you.

Changes to this product data sheet are reserved.

Please contact the sales staff (sales@hiitio.com) for further information on the product, technology, delivery terms, conditions and prices.