

HCS450FH220D3T1

2200V/450A Half Bridge SiC MOSFET Module

Description

The HCS450FH220D3T1 is a Half Bridge SiC MOSFET Power Module. It integrates high performance SiC MOSFET chips designed for the applications such as Motor drives and Renewable energy.



Features

- 2200V/4.2mΩ
- Low thermal resistance with AIN AMB
- Low Inductive Design
- Thermistor inside

Applications

- xEV Applications
- Motor Drives
- Renewable energy

Circuit diagram

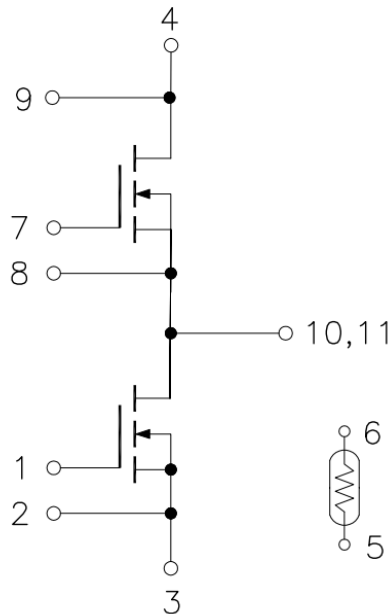

Figure 1. Out drawing & circuit diagram for HCS450FH220D3T1

HCS450FH220D3T1

2200V/450A Half Bridge SiC MOSFET Module

Pin Configuration and Marking Information

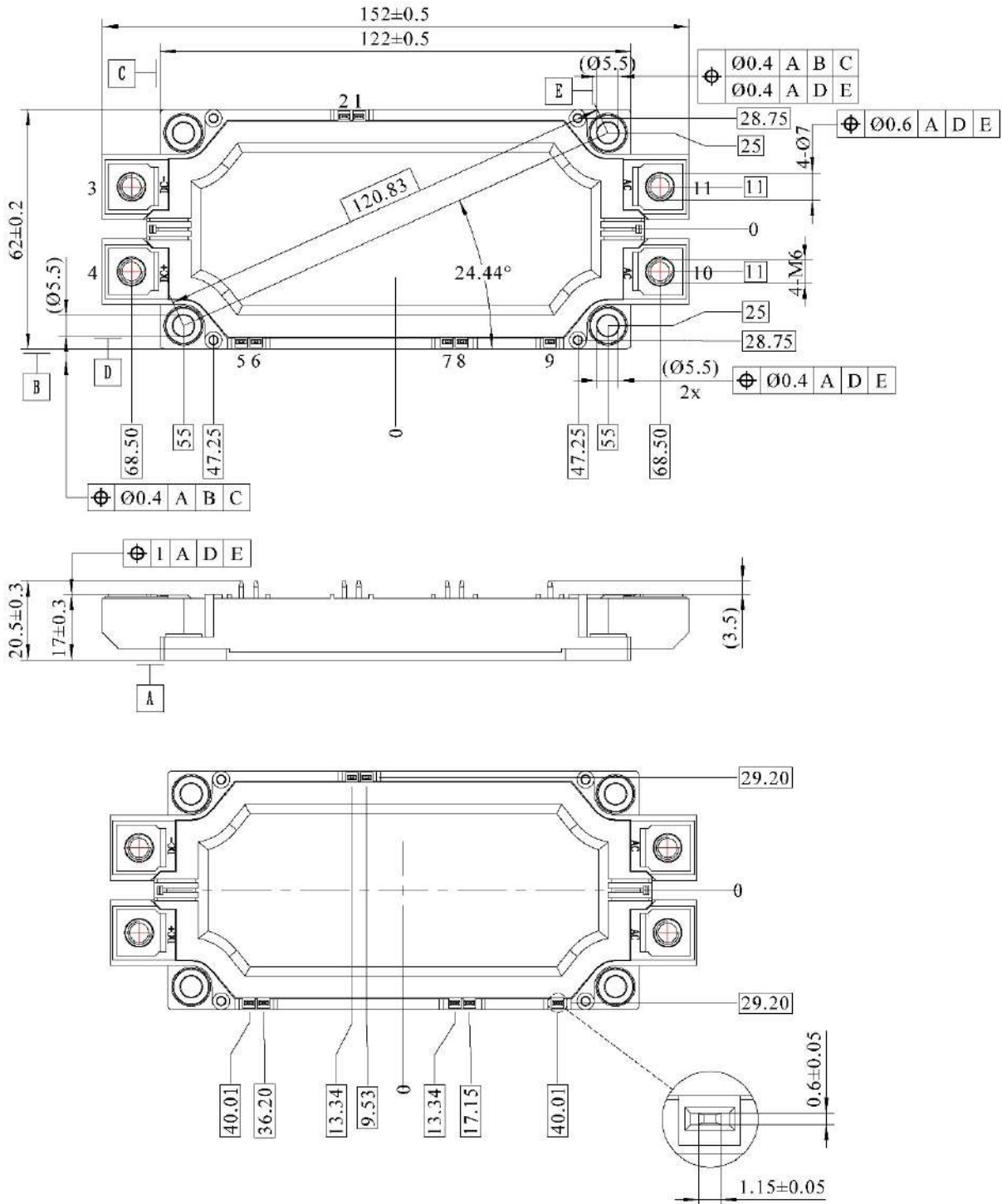

Figure 2. Pin configuration

HCS450FH220D3T1

2200V/450A Half Bridge SiC MOSFET Module

Module

Parameter	Condition	Value	Unit
Isolation Voltage	RMS, f =50Hz, t =1min	4.0	kV
Material of module baseplate	-	Cu	-
Creepage distance	terminal to heatsink terminal to terminal	14.5 13	mm
Clearance	terminal to heatsink terminal to terminal	12.5 10	mm
CTI	-	600	-
Module lead resistance, terminals – chip	T _c =25°C	0.5	mΩ
Mounting torque for module mounting	M5, M6	3 to 6	Nm
Weight	-	350	g

Maximum Ratings (T_j =25°C unless otherwise specified)

Symbol	Parameter	Condition	Ratings	Unit
V _{DSS}	Drain-Source Voltage	G-S Short	2200	V
V _{GSS}	Gate-Source Voltage	D-S Short, AC frequency ≥1Hz, Note1	-10 to 25	V
I _{DS}	DC Continuous Drain Current	T _C =25°C , V _{GS} =+20V	520	A
I _{DS}	DC Continuous Drain Current	T _C =60°C , V _{GS} =+20V	440	A
I _{SD}	Source (Body diode) Current	T _C =25°C, with ON signal	520	A
I _{SD}	Source (Body diode) Current	T _C =60°C, with ON signal	440	A
I _{DSM}	Pulse Drain Current	T _C =25°C, Pulse width =1ms, V _{GS} =+20V, Note2	1000	A
P _{tot}	Total Power Dissipation	T _C =25°C	2273	W
T _{Jmax}	Max Junction Temperature	-	150	°C
T _{stg}	Storage Temperature	-	-40 to 125	°C

Note1: Recommended Operating Value, +20V/-6V

Note2: Pulse width limited by maximum junction temperature

NTC characteristics

Symbol	Parameter	Condition	Value			Unit
			Min.	Typ.	Max.	
R ₂₅	Resistance	T _c =25°C	-	5	-	kΩ
△R/R	Deviation of R ₁₀₀	T _c =100°C, R ₁₀₀ =493 Ω	-5	-	5	%
P ₂₅	Power dissipation	T _c =25°C	-	-	20	mW
B _{25/50}	B-value	R ₂ =R ₂₅ exp [B _{25/50} (1/T ₂ - 1/(298,15 K))]	-	3375	-	K
B _{25/80}	B-value	R ₂ =R ₂₅ exp [B _{25/80} (1/T ₂ - 1/(298,15 K))]	-	3411	-	K
B _{25/100}	B-value	R ₂ =R ₂₅ exp [B _{25/100} (1/T ₂ - 1/(298,15 K))]	-	3433	-	K

HCS450FH220D3T1

2200V/450A Half Bridge SiC MOSFET Module

MOSFET Electrical characteristics ($T_j=25^\circ\text{C}$ unless otherwise specified, chip)

Symbol	Item	Condition	Value			Unit	
			Min.	Typ.	Max		
$V_{(BR)DSS}$	Drain-Source Breakdown Voltage	$V_{GS}=0V, I_D=1mA$	2200	-	-	V	
I_{DSS}	Zero gate voltage drain Current	$V_{DS}=2200V, V_{GS}=0V$	-	-	200	μA	
$V_{GS(th)}$	Gate-source threshold Voltage	$I_D=170mA, V_{DS}=10V$	3.5	4.5	5.5	V	
I_{GSS}	Gate-Source Leakage Current	$V_{GS}=25V/-10V, V_{DS}=0V$	-	-	± 400	nA	
$R_{DS(on)}$ (Chip)	Static drain-source On-state resistance	$I_D=450A$ $V_{GS}=+20V$	$T_j=25^\circ\text{C}$	-	4.2	-	m Ω
			$T_j=150^\circ\text{C}$	-	8.4	11.8	m Ω
$V_{DS(on)}$ (Chip)	Static drain-source On-state Voltage	$I_D=450A$ $V_{GS}=+20V$	$T_j=25^\circ\text{C}$	-	1.89	-	V
			$T_j=150^\circ\text{C}$	-	3.78	5.31	V
R_{Gint}	Internal Gate Resistance	$T_j=25^\circ\text{C}$	-	4.1	-	Ω	
C_{iss}	Input Capacitance	$V_{DS}=1100V, V_{GS}=0V, f=10kHz$	-	36.7	-	nF	
C_{oss}	Output Capacitance		-	1.2	-	nF	
C_{rss}	Reverse transfer Capacitance		-	0.03	-	nF	
Q_g	Total gate charge	$V_{DS}=1100V, I_D=170A, V_{GS}=+20V/-6V$	-	1080	-	nC	
$t_{d(on)}$	Turn-on delay time	$V_{DD}=1100V$ $I_D=450A$ $V_{GS}=+20/-6V$ $R_{gon}/R_{goff}=0.75/3.0\Omega$ Inductive load switching operation	$T_j=25^\circ\text{C}$	-	135	-	ns
			$T_j=150^\circ\text{C}$	-	160	-	
t_r	Rise time		$T_j=25^\circ\text{C}$	-	35	-	ns
			$T_j=150^\circ\text{C}$	-	40	-	
$t_{d(off)}$	Turn-off delay time		$T_j=25^\circ\text{C}$	-	345	-	ns
			$T_j=150^\circ\text{C}$	-	300	-	
t_f	Fall time		$T_j=25^\circ\text{C}$	-	115	-	ns
			$T_j=150^\circ\text{C}$	-	60	-	
E_{on}	Turn-on power dissipation		$T_j=25^\circ\text{C}$	-	16.0	-	mJ
			$T_j=150^\circ\text{C}$	-	14.2	-	
E_{off}	Turn-off power dissipation	$T_j=25^\circ\text{C}$	-	24.8	-	mJ	
		$T_j=150^\circ\text{C}$	-	22.6	-		
$R_{th(j-c)}$	FET Thermal Resistance	Junction to Case	-	0.055	-	K/W	
$R_{th(c-f)}$	Contact thermal Resistance	With thermal conductive grease, Note3	-	0.015	-	K/W	

Note3: Assumes Thermal Conductivity of grease is $0.9W/m \cdot K$ and thickness is 50 μm .

HCS450FH220D3T1

2200V/450A Half Bridge SiC MOSFET Module

Body Diode Electrical characteristics ($T_j=25^\circ\text{C}$ unless otherwise specified, chip)

Symbol	Item	Condition	Value			Unit	
			Min.	Typ.	Max.		
V_{SD}	Body Diode Forward Voltage	$V_{GS} = -6\text{V}$ $I_{SD} = 450\text{A}$	$T_j = 25^\circ\text{C}$	-	3.0	-	V
			$T_j = 150^\circ\text{C}$	-	5.0	-	
T_{rr}	Reverse recovery time	$V_{DD} = 1100\text{V}$, $I_D = 450\text{A}$ $V_{GS} = +20/-6\text{V}$,	$T_j = 25^\circ\text{C}$	-	40	-	ns
			$T_j = 150^\circ\text{C}$	-	30	-	
E_{rr}	Diode switching power dissipation	$R_{gon}/R_{goff} = 0.75/3.0\Omega$ Inductive load	$T_j = 25^\circ\text{C}$	-	1.35	-	mJ
			$T_j = 150^\circ\text{C}$	-	1.20	-	

Test Conditions

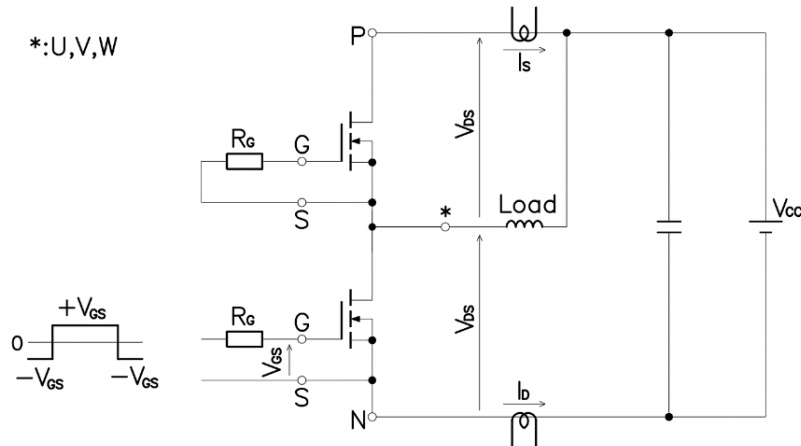

Figure 3. Switching time measure circuit

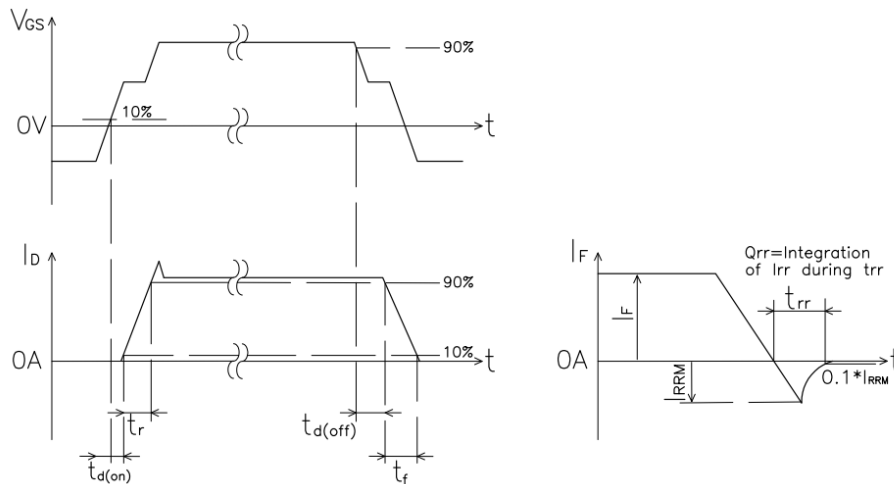

Figure 4. Switching time definition

HCS450FH220D3T1

2200V/450A Half Bridge SiC MOSFET Module

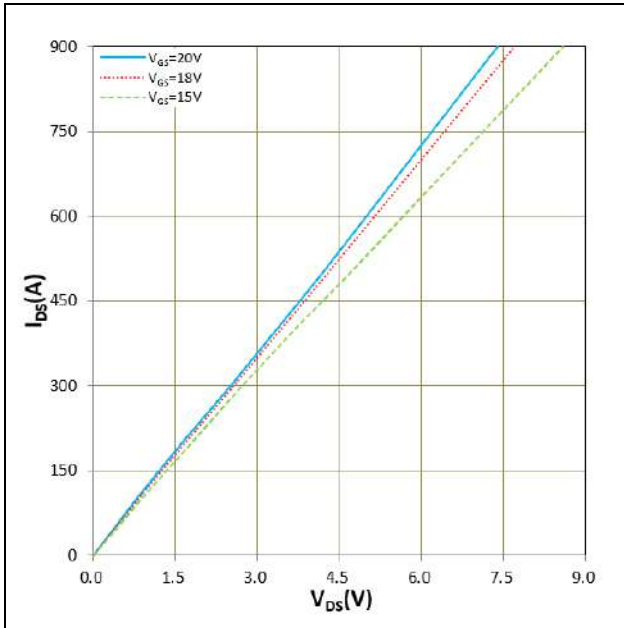

Figure 5. I_{DS} vs V_{DS}
 $T_j = 150^\circ\text{C}$

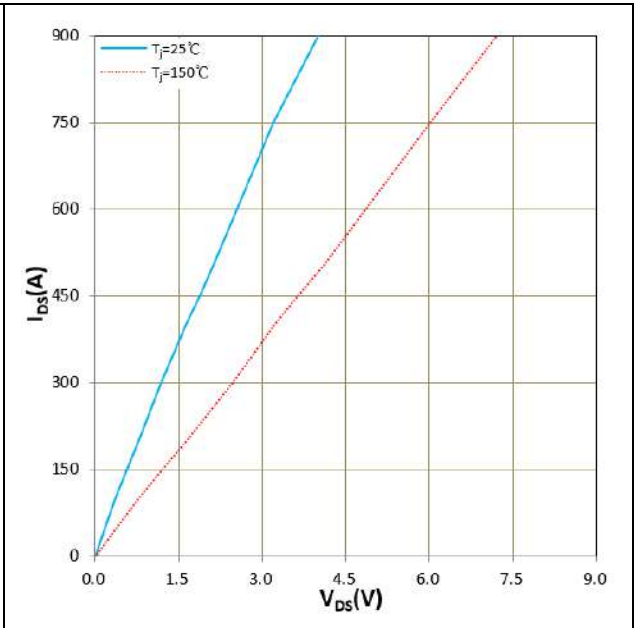

Figure 6. I_{DS} vs V_{DS}
 $V_{GS} = +20\text{V}$

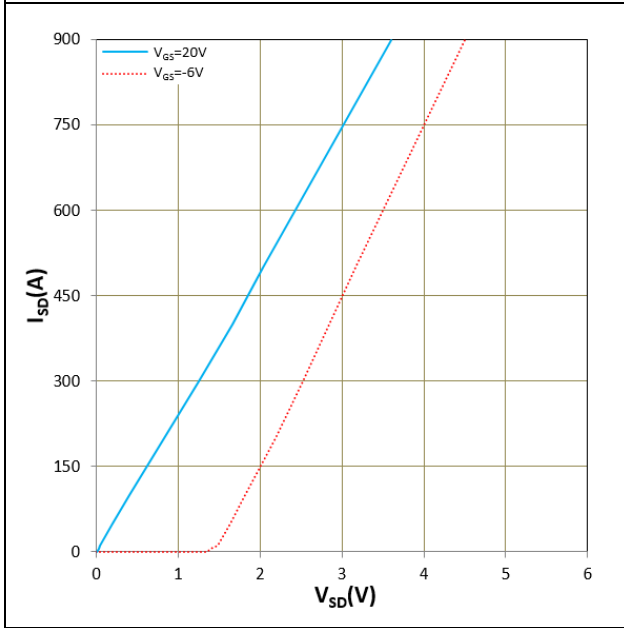

Figure 7. I_{SD} vs $V_{SD} (V_F)$
 $T_j = 25^\circ\text{C}$

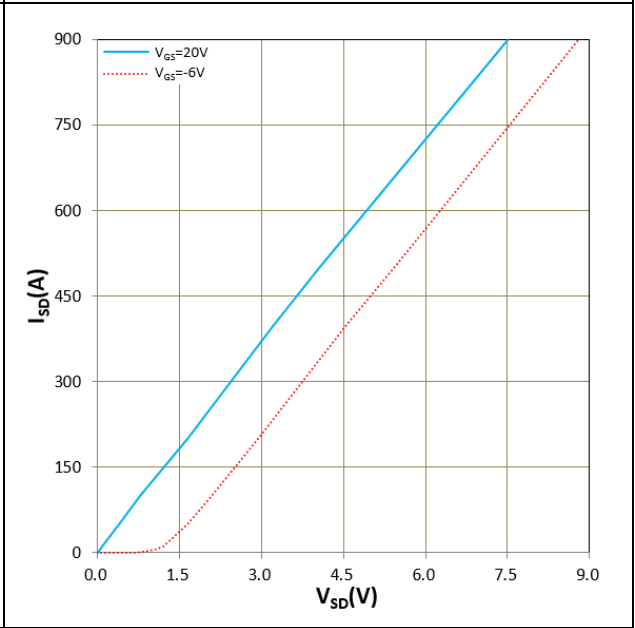

Figure 8. I_{SD} vs $V_{SD} (V_F)$
 $T_j = 150^\circ\text{C}$

HCS450FH220D3T1

2200V/450A Half Bridge SiC MOSFET Module

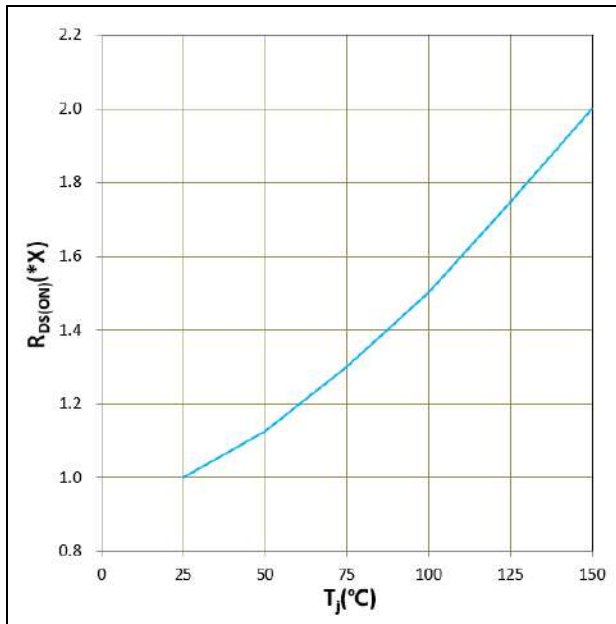

Figure 9. $R_{DS(ON)}$ vs T_j
 $V_{GS} = +20V$, $I_D = 450A$, $1.0X = 4.2m\Omega$

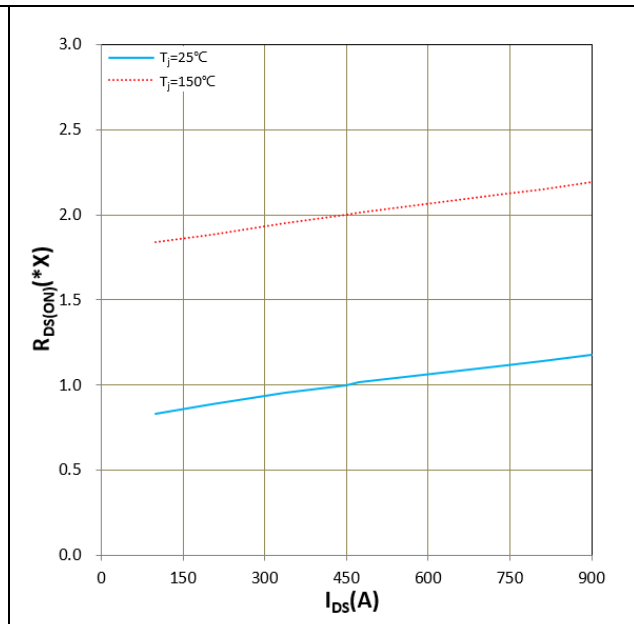

Figure 10. $R_{DS(ON)}$ vs I_{DS}
 $V_{GS} = +20V$, $1.0X = 4.2m\Omega$

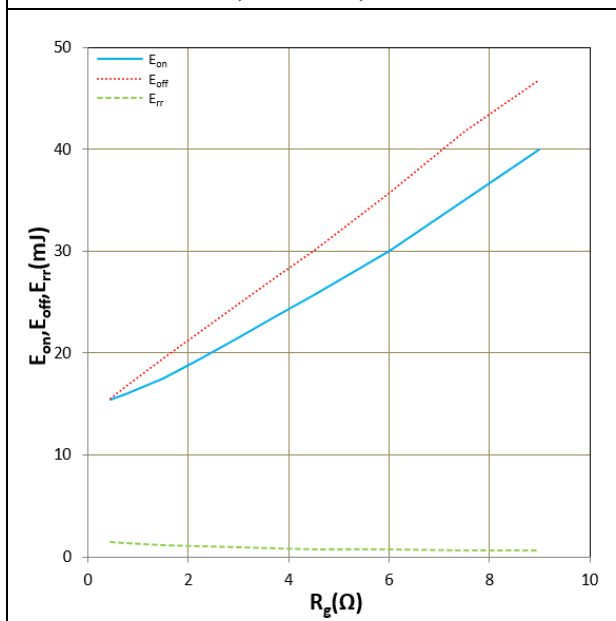

Figure 11. E_{on} , E_{off} , E_{rr} vs R_g
 $T_j = 25^\circ C$, $V_{DD} = 1100V$, $I_D = 450A$, $V_{GS} = +20V/-6V$
 Inductive Load

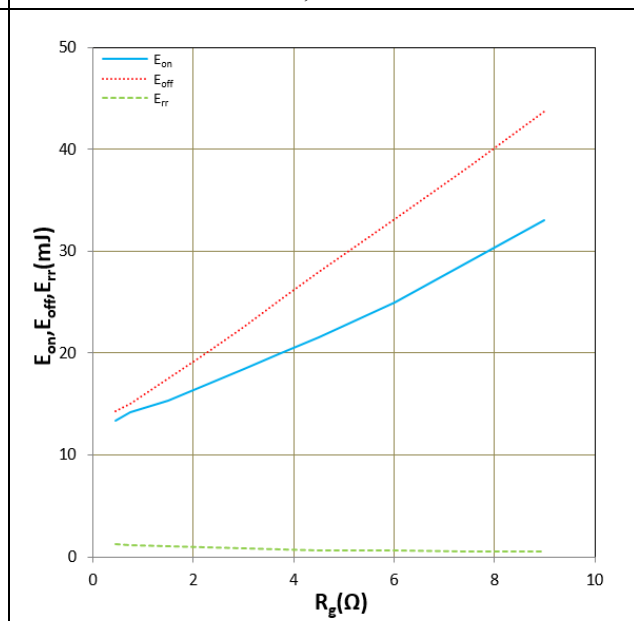

Figure 12. E_{on} , E_{off} , E_{rr} vs R_g
 $T_j = 150^\circ C$, $V_{DD} = 1100V$, $I_D = 450A$, $V_{GS} = +20V/-6V$
 Inductive Load

HCS450FH220D3T1

2200V/450A Half Bridge SiC MOSFET Module

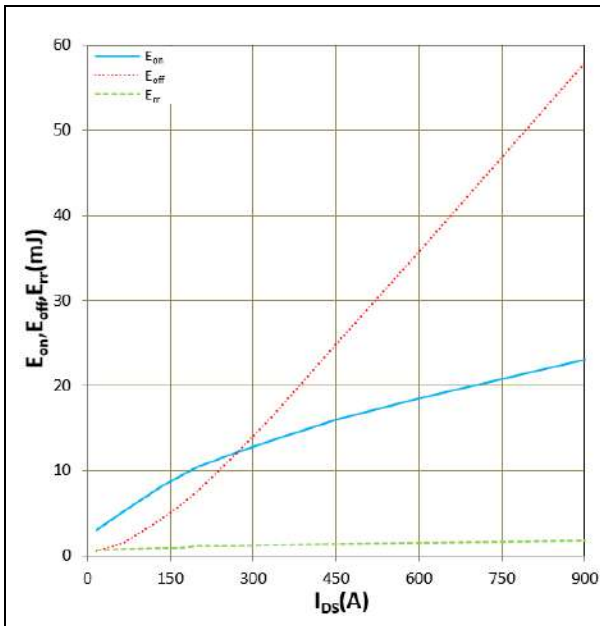

Figure 13. E_{on} , E_{off} , E_{rr} vs I_{DS}
 $T_j = 25^\circ\text{C}$, $V_{DD} = 1100\text{V}$, $R_{GON} / R_{GOFF} = 0.75/3.0 \Omega$
 $V_{GS} = +20\text{V}/-6\text{V}$, Inductive Load

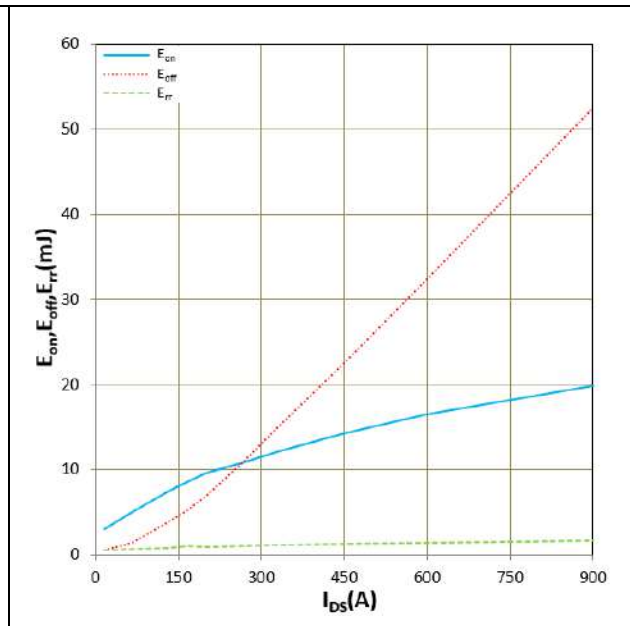

Figure 14. E_{on} , E_{off} , E_{rr} vs I_{DS}
 $T_j = 150^\circ\text{C}$, $V_{DD} = 1100\text{V}$, $R_{GON} / R_{GOFF} = 0.75/3.0 \Omega$
 $V_{GS} = +20\text{V}/-6\text{V}$, Inductive Load

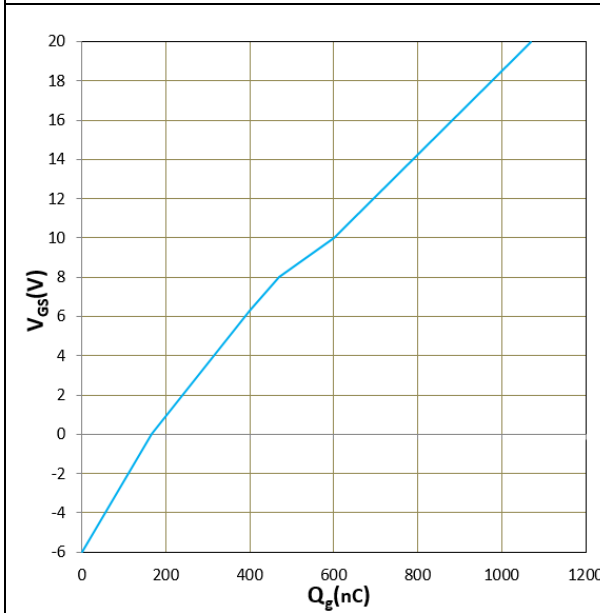

Figure 15. V_{GS} vs Q_g
 $V_{CC} = 1100\text{V}$, $I_D = 450\text{A}$, $T_j = 150^\circ\text{C}$

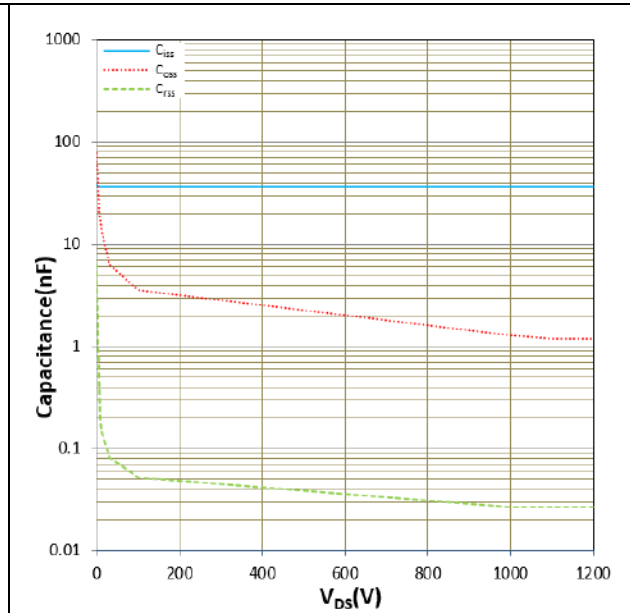
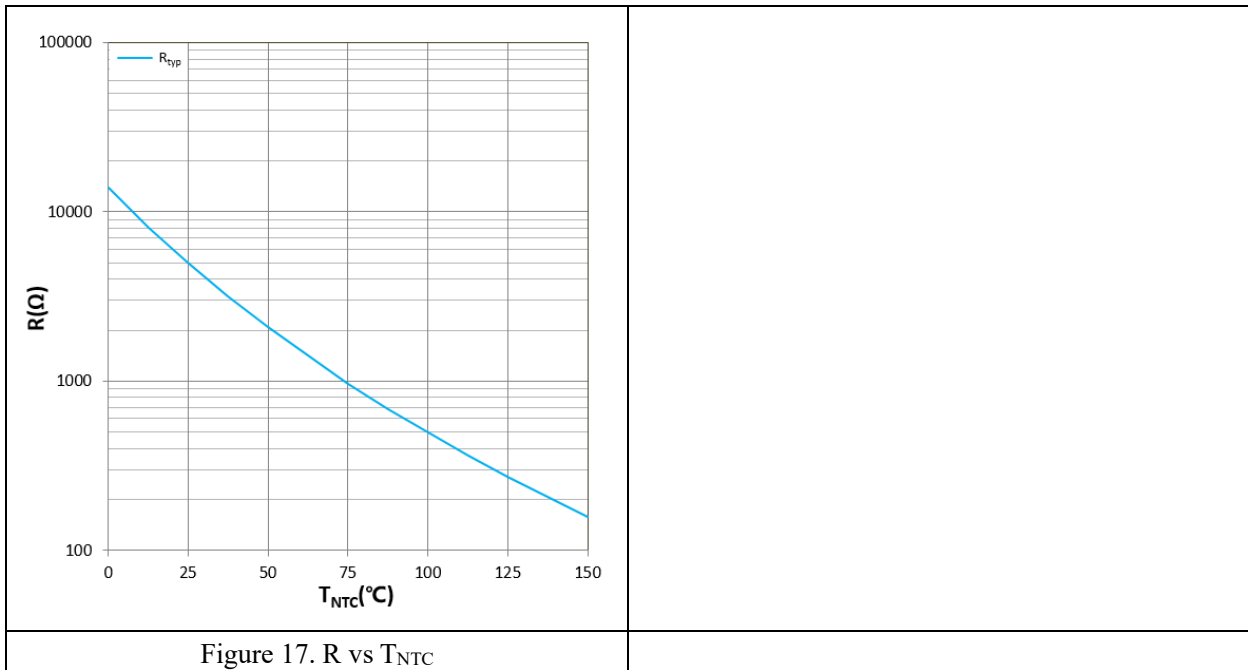

Figure 16. C_{ies} , C_{oss} , C_{rss} vs V_{DS}
 $T_j = 25^\circ\text{C}$, $V_{GS} = 0\text{V}$, $f = 10\text{kHz}$

HCS450FH220D3T1

2200V/450A Half Bridge SiC MOSFET Module



IMPORTANT NOTICE

This product data sheet describes the characteristics of this product for which a warranty is granted. Any such warranty is granted exclusively under the terms and conditions of the supply agreement. There will be no guarantee or of any kind for the product and its characteristics.

The data contained in this document is exclusively intended for technically trained staff. You and your technical departments will have to evaluate the product's suitability for the intended application and the completeness of the product data concerning such application.

Due to technical requirements, our product may contain dangerous substances. For information on the types in question, please contact the sales staff responsible for you.

Changes to this product data sheet are reserved.

Please contact the sales staff (sales@hiitio.com) for further information on the product, technology, delivery terms, conditions and prices.

Revision History

Document Version	Description of Changes
RevX.0.1	Released

Zhejiang HIITIO New Energy Co., Ltd

ADD : NO.1125 Zhixing Road,Qiaonan District, Xiaoshan Economic and
Technological Development Zone, Hangzhou, Zhejiang

TEL :400-667-9977

